

Microlab STAR Line Operator's Manual



Important notice

This manual may not be used or reproduced in any way whatsoever without the express written consent of Hamilton Bonaduz AG.

Copyright © 2017 Hamilton Bonaduz AG, All Rights Reserved.

Microlab is a registered trademark of Hamilton Bonaduz AG.

Microtiter is a registered trademark of Dynatech Laboratories.

Deconex is a registered trademark of Borer Chemie AG Switzerland.

Windows 7, Window 10 and Excel are registered trademarks of Microsoft Corporation.

Intel is a registered trademark of Intel Corporation.

Table of Contents

1. Safety and General Information	1
1.1 About this Manual	1
1.2 Additional ML STAR Manuals	2
1.3 Intended use of the ML STAR	2
1.4 Operation	2
1.5 Training	2
1.6 Legal Regulations.....	3
1.7 Safety Precautions and Hazards	3
1.7.1 General Precautions	3
1.7.2 Biohazard and Chemical Precautions.....	7
1.7.3 Computer Precautions	7
1.7.4 Electrical Safety Precautions	7
1.7.5 Hazards.....	8
2. Description of the ML STAR.....	15
2.1 ML STAR	15
2.1.1 The Air Displacement Pipetting Principle.....	15
2.1.2 Tip Pick-up with the CO-RE Technology	16
2.1.3 Tip Recognition	17
2.1.4 Liquid Level Detection: LLD	18
2.1.5 Monitored Air Displacement: MAD.....	19
2.1.6 Capacitance-Based Clot Detection	20
2.1.7 Anti-Droplet Control: ADC.....	20
2.1.8 Total Aspiration and Dispensing Monitoring: TADM.....	21
2.1.9 Availability of Technologies on the Pipetting Tools	22
2.2 Platforms.....	22
2.2.1 ML STARlet.....	24
2.2.2 ML STAR	24
2.2.3 ML STARPlus	25
2.3 Pipetting Arm Configurations.....	26
2.3.1 Modular Pipetting Arm	26
2.3.2 Modular Pipetting Arm MPH	27
2.3.3 Pipetting Arm MPH/iSWAP	28
2.3.4 Pipetting Arm MPH	29
2.3.5 iSWAP Arm	29
2.3.6 Dual-Arm Configurations.....	30
2.4 Options and Upgrades	31

2.4.1	1000µl-Pipetting Channels.....	32
2.4.2	5ml-Pipetting Channels.....	36
2.4.3	CO-RE 96 Probe Head	39
2.4.4	CO-RE 96 Probe Head TADM.....	43
2.4.5	CO-RE 384 Probe Head	44
2.4.6	Pin Tools	48
2.4.7	iSWAP.....	49
2.4.8	Tube Gripper.....	50
2.4.9	AutoLys Tube Channel	51
2.4.10	Tube-Twister Channel and Decapper Module.....	52
2.4.11	Imaging Channel.....	55
2.4.12	Imaging Applications.....	56
2.4.13	Multiflex Media Line	57
2.4.14	CO-RE Gripper	58
2.4.15	FlipTube Tool	59
2.4.16	CO-RE Lid Tool.....	61
2.4.17	Autoload Option	62
2.5	Accessories	63
2.5.1	Carriers	64
2.5.2	Multiflex Carrier	65
2.5.3	Hamilton SBS Centrifuge	66
2.5.4	HAMILTON Heater Shaker	67
2.5.5	Multiflex Heating and Multiflex Cooling Module.....	72
2.5.6	Multiflex Cooling-Heating Module	74
2.5.7	On Deck Thermo Cycler (ODTC).....	76
2.5.8	Freezer Carrier.....	77
2.5.9	CR Needle Wash Station and Pump Unit.....	77
2.5.10	Dual Chamber 96/384 Wash Station	81
2.5.11	Temperature Controlled Carrier (TCC).....	82
2.5.12	Crystal Vacuum System.....	83
2.5.13	HEPA Filter Hoods.....	87
2.6	Tips and Needles	88
2.6.1	Tip Packaging	89
2.6.2	Tips for Pipetting Low Volumes from 0.5-10µl.....	91
2.6.3	Tips for Pipetting Sample Volumes from 1-50µl	92
2.6.4	Tips for Pipetting Sample Volumes from 0.5-50µl Using the 384 MPH.....	93
2.6.5	Tips for Pipetting Sample Volumes from 10-300µl	93
2.6.6	Tips for Pipetting Sample Volumes from 10-1000µl	94
2.6.7	Tips for Pipetting Sample Volumes from 50-5000µl	95
2.6.8	Special Tips: Rocket tip	96
2.6.9	Special Tips: Piercing Tip	96

2.6.10	Special Tips: Extra-long and Slim Tip.....	97
2.6.11	Special Tips: Wide Bore Tips.....	98
2.6.12	Needles.....	99
2.7	Computer Requirements.....	99
2.8	VENUS Software.....	100
2.9	Electronics and Interfaces.....	100
2.9.1	Interfaces of the Dual Processor Board.....	101
2.9.2	Interfaces of the LAN Dual Processor Board.....	102
2.10	ML STAR Power / Voltage.....	103
3.	Routine Use.....	104
3.1	Loading the ML STAR Instrument.....	104
3.1.1	Method Trace File.....	109
3.1.2	Communication Trace File.....	109
3.1.3	Single Step Mode.....	109
3.1.4	Run Simulations.....	110
3.2	Retrieving Objects.....	111
3.2.1	Retrieving Objects from the iSWAP.....	111
3.2.2	Retrieving objects from the Tube Twister Channel.....	112
3.2.3	Retrieving objects from the Decapper Module.....	114
3.3	Error Handling.....	115
3.3.1	Run-Time Error Handling.....	115
3.3.2	Run-Time Error Handling Examples.....	116
4.	Maintenance.....	120
4.1	STARwatch Advanced Service.....	120
4.2	Maintenance Intervals.....	121
4.3	If Maintenance Fails.....	122
4.4	Preventative Maintenance.....	122
4.5	Materials Required.....	122
4.6	Instrument Maintenance Procedures.....	123
4.6.1	Daily Maintenance.....	124
4.6.2	Weekly Maintenance.....	126
4.7	Printing a Report.....	131
4.8	Needle Maintenance.....	131
4.9	CO-RE 96 Probe Head TADM.....	132
4.9.1	Preparation.....	133
4.9.2	Daily Maintenance.....	137
4.9.3	Weekly Maintenance.....	141

4.10	CR Needle Wash Station	144
4.10.1	Daily Maintenance	144
4.10.2	Weekly Maintenance.....	145
4.11	CO-RE 96/384 Dual Wash Station	146
4.11.1	Daily Maintenance	146
4.11.2	Weekly Maintenance.....	147
4.12	Hamilton Heater Shaker	148
4.13	Crystal Vacuum System.....	148
4.13.1	Activating the CVS Maintenance	148
4.13.2	Daily Maintenance	149
4.13.3	Weekly Maintenance.....	149
4.14	Temperature Controlled Carrier (TCC).....	150
4.15	Multiflex Cooling-Heating Module	150
5.	ML STAR Instrument Decontamination.....	152
5.1	Surface Decontamination using Liquids.....	154
5.2	Decontamination using Gases	154
5.3	Decontamination using UV Light.....	154
6.	Verification.....	156
6.1	General Description.....	156
7.	Technical Specifications	158
7.1	Basic ML STAR Specifications	158
7.2	Pipetting Specifications	159
7.2.1	Disposable Tips with 1000µl Pipetting Channels.....	159
7.2.2	Needles with 1000µl Pipetting Channels	159
7.2.3	Disposable Tips with 5ml Pipetting Channels.....	160
7.2.4	Disposable Tips with 1000µl CO-RE 96 Probe Head.....	160
7.2.5	Disposable Tips with 50µl CO-RE 384 Probe Head.....	160
7.2.6	Disposable Tips with 50µl CO-RE 384 Probe Head as 96 Probe Head.....	161
7.2.7	Operating Data for Tips.....	161
7.2.8	Storage Data for Tips.....	161
7.3	Liquid Level Detection	161
7.4	Throughput	162
7.5	Operating Data.....	162
7.6	Storage and Transportation.....	163
7.7	Lifespan.....	163
7.8	Materials Used in ML STAR Line Instruments and Accessories	163
7.9	Communication	163

7.10	PC Minimum Requirements	163
7.11	Hamilton Standard PC Specifications Windows 7.....	164
7.12	Hamilton Standard PC Specifications Window 10.....	165
7.13	Touch Screen Monitor Specifications for the ML STAR Line	166
7.14	CR Needle Wash Station Specifications	166
7.15	CO-RE 96/384 Dual Wash Station Specifications	167
7.16	iSWAP Specifications.....	168
7.17	Tube Gripper Specifications	169
7.18	CO-RE Gripper 1000µl Specifications	170
7.19	CO-RE Gripper 5ml Specifications	171
7.20	Hamilton SBS Centrifuge Specifications	172
7.21	48VDC Power Box Specifications.....	172
7.22	Hamilton Heater Shaker Specifications	173
7.23	Hamilton Heater Shaker Box (HSB) Specifications	174
7.24	Crystal Vacuum System (CVS) Specifications	175
7.25	Temperature Controlled Carrier (TCC) Specifications	175
7.26	Multiflex Heating Module Specifications.....	176
7.27	Multiflex Cooling Module Specifications	176
7.28	Multiflex Cooling-Heating Module Specifications	177
7.29	Tube Twister Channel and Decapper Module Specifications.....	178
7.30	Autoload Option: Barcode and Reader Specifications	179
7.30.1	Barcode Symbologies	179
7.30.2	Reading Accuracy.....	179
7.30.3	Barcode Specifications	180
7.30.4	Sample Barcodes.....	181
7.30.5	Reagent Barcodes	182
7.30.6	Plate Barcodes.....	183
8.	Appendices	186
8.1	Appendix A: Chemical Compatibility	186
8.1.1	Abbreviations of Metals and Polymers Used in the Following Tables	186
8.1.2	Chemical Resistance of the Multi-Probe Heads	187
8.1.3	Chemical Resistance of the CR Needle Wash Station.....	188
8.1.4	Chemical Resistance of the Wash Station.....	189
8.1.5	Chemical Resistance of the 96/384 Wash Station	190
8.1.6	Chemical Resistance of the CVS.....	191
8.2	Appendix B: Ordering Information	192
8.2.1	Standard Tips.....	192

8.2.2	Steel Needles for 1000µl Single Channels	195
8.2.3	Teaching Needles	196
8.2.4	10µl Low Volume Tips	196
8.2.5	50µl Standard Tips for CO-RE 384 Probe Head	197
8.2.6	250µl Robotic Piercing Tips for CO-RE 96-Probe Heads.....	198
8.2.7	300µl SPECIAL TIPS Extra-Long and Slim Tips	198
8.2.8	300µl Rocket Tips for CO-RE 384 Probe Head.....	199
8.2.9	300µl Wide Bore Tips	199
8.2.10	1000µl Wide Bore HIGH Tips for CO-RE 96 Probe Head	200
8.2.11	FlipTube System	200
8.2.12	Disposable Waste Bags.....	202
8.2.13	Reagent Containers	202
8.2.14	Deep Well Plates	203
8.2.15	Liquids for Maintenance.....	204
8.2.16	Plate Carrier.....	205
8.2.17	Reagent Carrier	206
8.2.18	Tip Carrier	207
8.2.19	Sample Tube Carrier and Inserts.....	208
8.2.20	Multiflex Carrier	209
8.2.21	Temperature Controlled Carrier (TCC).....	213
8.2.22	CVS Vacuum System	214
8.2.23	Hamilton Heater Shaker.....	216
8.2.24	3 rd Party Shakers	217
8.2.25	Wash Stations.....	218
8.2.26	Multiflex Media Line	218
8.2.27	HEPA Filter Hoods.....	219
8.2.28	Housing Extension	221
8.2.29	CO-RE Tools.....	222
8.2.30	Emergency Stop Box	222
8.2.31	Mains Power Cables	223
8.2.32	Hamilton Standard Computers	224
8.2.33	Touch Screen Monitor for the ML STAR.....	224
8.2.34	VENUS Software	225
8.3	Appendix C: Instrument Dimensions	226
8.3.1	ML STARlet, Manual Load, Shown Without Housing	226
8.3.2	ML STARlet, Autoload	227
8.3.3	ML STARlet, Autoload, MPH	228
8.3.4	ML STARlet, on Bench with Doors and PC	229
8.3.5	ML STARlet, on Table with PC	230
8.3.6	ML STAR, Manual Load.....	231
8.3.7	ML STAR, Manual Load, MPH	232

8.3.8	ML STAR, Manual Load with HEPA Hood.....	233
8.3.9	ML STAR, Autoload	234
8.3.10	ML STAR, Autoload, Extension Housing Left.....	235
8.3.11	ML STARPlus, Manual Load, 30T	236
8.3.12	ML STARPlus, Manual Load, 50T	237
8.3.13	ML STARPlus, Manual Load, 71T	238
8.3.14	ML STARPlus, Autoload, 30T	239
8.3.15	ML STARPlus, Autoload, 50T	240
8.3.16	ML STARPlus, Autoload, 71T.....	241
8.3.17	Chemagic STAR	242
8.4	Appendix D: Regulatory Affairs.....	243
8.4.1	Radio Interference (USA and Canada).....	243
8.4.2	<i>In vitro</i> Diagnostics.....	243
8.4.3	Applied Company Quality Management Systems	243
8.4.4	Declaration of Conformity: CE, CSA.....	244
8.4.5	Declaration of Quality.....	245
8.4.6	WEEE Declaration	246
8.4.7	RoHS Compliance	247
8.4.8	21 CFR Part 11 Compliance.....	248
8.5	Appendix E: Glossary	256

1. Safety and General Information

Hamilton's Microlab STAR, Microlab STARlet, and Microlab STARPlus are in the following summarized as ML STAR. This Operator's Manual is designed to get the most out of a ML STAR pipetting workstation.

Please read through the entire manual before beginning to operate the instrument. This first section should be read with particular attention. It contains important information about the use of the ML STAR and this manual.

1.1 About this Manual

This manual is meant to help users operate the ML STAR instruments correctly and safely.

To achieve this goal, the manual will describe the different components of the ML STAR and how they work. This manual mainly describes the hardware of the ML STAR instrument in depth, which enables the user to operate the instrument. The software is described in the Microlab STAR Programmer's Manual.

The introduction to the various parts of the ML STAR is followed by a step by step description how to operate the instrument. Working through this manual provides the operator all the needed information to operate the ML STAR.

Warnings and **notes** are included in this manual in order to emphasize important and critical instructions. They are printed in *Italics*, beginning with the word **ATTENTION** or **NOTE** as appropriate.



ATTENTION

Any special problems, warning or important information will be accompanied by this symbol. Read these items carefully.



NOTE

Information is given to the programmer that is useful but not essential to the task at hand.

- [...] Push buttons and their corresponding description.
- "..." Description for all kinds of entry fields, control fields, checkboxes, lists, etc.
- ___ References to manuals, figures, sections, etc.

This manual refers to VENUS four Software for the ML STAR.

1.2 Additional ML STAR Manuals

For the programmer of the system, the [VENUS Software Programmer's Manual](#) describes all the features of the [Microlab STAR VENUS Software](#). A detailed software reference for the ML STAR can be found in the [Help Function of the VENUS Software](#).

The Total Aspiration and Dispensing Monitoring (TADM) is an additional safety tool for the pipetting process. The TADM feature allows optimization of the entire pipetting process by reading out the pressure curves and comparing them to a tolerance band in real-time. The description of its functions and how to work with TADM is described in the [TADM Manual](#).

VENUS Dynamic Scheduler is a software tool for organizing and controlling the workflows of a laboratory equipped with Hamilton instruments as well as other manufacturer's instruments. The use of this tool is described in the [VENUS Dynamic Scheduler User Manual](#).

VENUS Data Base Plus is a software tool that allows using additional functions on the VENUS Database. It allows tracking over multiple runs and the use of an SQL Server via the network. The use of this tool is described in the [Help Function of the VENUS Database Plus](#).

Further manuals for specific applications, standard solutions, workstations, features, etc. come together with the dedicated ML STAR instrument. Please refer to these specific manuals for the respective application.

1.3 Intended use of the ML STAR

The ML STAR is a robotic pipetting workstation which is classified as a general laboratory instrument and not as an *in vitro* diagnostic device. It is intended to automate routine pipetting tasks and the required transports of labware such as microplates and disposable tips used in the pipetting assay.

1.4 Operation

The operator of the ML STAR must have attended an appropriate training course. The procedures contained within this manual have been tested by the manufacturer and are deemed to be fully functional. Any deviation from the procedures given here could lead to erroneous results or malfunction.

During instrument operation, stand clear of all moving parts and the working deck of the instrument. In general, never lean over or into the instrument while it is in operation.

If the ML STAR is used in a manner not specified by Hamilton, the protection provided by the equipment may be impaired.

1.5 Training

Training courses will be held by a Hamilton representative. Please feel free to contact a local representative to arrange for an operator training.

Training in operation of the ML STAR instruments and general use of the VENUS Software will be provided by Hamilton personnel upon initial installation.

1.6 Legal Regulations

All local, state and federal laws which prescribe the use, application, and/or the handling of dangerous materials in connection with the instrument must be strictly followed.

1.7 Safety Precautions and Hazards

The following section describes the main safety considerations, electrical and biological, in operating this product, and the main hazards involved.



ATTENTION

Read the following safety notices carefully before using the ML STAR instrument.

1.7.1 General Precautions

1.7.1.1 Instrument Installation and Relocation

The ML STAR instrument is installed or relocated by a Hamilton trained field service engineer. Installations of instrument options and accessories are also done by a Hamilton trained field service engineer.

The ML STAR instruments conform to European norms regarding interference immunity. However, if the ML STAR is subject to electromagnetic RF fields, or if static electricity is discharged directly onto the ML STAR instrument, its Liquid Level Detection ability may be negatively affected. It is therefore recommended that the ML STAR instrument is kept away from other equipment that emits electromagnetic RF fields in the laboratory, and that static electricity is minimized in its immediate environment.

During routine operation, the ML STAR instrument should be shielded from direct sunlight and intense artificial light. The instrument should be positioned in the laboratory in a way permitting personnel to access the front and sides of the instrument in order to operate, maintain, open and close the protective covers. Accordingly, in order to calculate how much space is needed, consider the dimensions of the instrument (see [Section 7.1 Basic ML STAR Specifications](#)) and sufficient space for a person to move and work comfortably.

Never lift a fully installed instrument for transportation from one location to another. It must be re-installed in the new location by a Hamilton trained field service engineer.

Depending on size, the instrument weighs more than 150kg. Necessary precautions should be taken when transporting the instrument.

1.7.1.2 Maintenance, Service and Repair

Maintaining the instrument on a regular basis (e.g. cleaning operations) is a task of the instrument's operator (see [Section 4 Maintenance](#)).

Exchanging spare parts, repair and performing preventive maintenance on the ML STAR instrument are tasks for a Hamilton trained field service engineer.



ATTENTION

Only original Hamilton ML STAR specific parts, tools and consumables may be used with the ML STAR instrument (e.g. carriers, racks, tips, steel needles, and waste containers). Of course, commercially available liquid containers, labware such as microplates and tubes, may be used.

A breakdown of the power supply during a run may cause loss of data. If data loss is unacceptable, use an independent power supply.

For repair or shipment, all mechanical parts must be placed in their initial positions. An instrument packed and shipped for repair must also be decontaminated (see [Section 5 ML STAR Instrument Decontamination](#)) if it was in a laboratory environment with infectious or hazardous materials. The ML STAR instrument must be repacked in the original shipping crate by a Hamilton trained field service engineer only; please contact a local Hamilton representative. No containers or tips on the ML STAR may be in the instrument during transportation.

1.7.1.3 Qualities of Hamilton Solutions

The table below shows the Qualities of Hamilton Solutions which depicts the responsibilities of both Hamilton and the Customer.

Quality of Hamilton Solutions				
	DQ	IQ (Installation Qualification)	OQ (Operation Qualification)	PQ (Process Qualification)
Responsible	Hamilton: System Customer: Assay	Hamilton	Hamilton/Customer	Customer
			Verification of the customer's specifications Training	

1.7.1.4 Operating the Instrument

When using the ML STAR, Good Laboratory Practices (GLP) must be observed. Suitable protective clothing, safety glasses and protective gloves must be worn, particularly when dealing with a malfunction of the instrument where the risk of contamination from spilled liquids exists.

Electrostatic discharge can cause damage to the instrument and can influence labware behavior and stability, therefore avoid any electrostatic charge onto labware and disposable tips during handling and manual loading of these to or from the ML STAR instrument.

During instrument operation, stand clear of all moving parts and the working deck of the instrument. In general, never lean over or into the instrument while it is in operation.

If the ML STAR is used in a manner not specified by Hamilton, the protection provided by the equipment may be impaired.

When using aggressive or corrosive liquids, ensure that filter tips are being used. Do not re-use tips. Replace stop disks and O-rings more frequently; make sure to PM the instrument in shorter intervals since the system will need a higher level of support and maintenance. To avoid corrosion on the deck, use an exhaust suction device to remove corrosive fumes away from the deck.



ATTENTION

When using flammable or explosive fluids or vapors, necessary precautions must be taken. There is a high risk of damage to health and to the instrument. The instrument is not explosion-proof.

1.7.1.5 Method Programming

Perform test runs first with water and then with the final liquids, prior to routine use. Test all liquid classes which will be used. A newly programmed test method must first be run on the ML STAR instrument with the final liquids, prior to validation of the method and routine use. The method programmer should supervise this run.

Before using any newly created or modified methods for routine test purposes, a comparison study between the method previously used and the new one must be carried out by the laboratory supervisor in order to ensure that the processing and data evaluation of both methods produce equal results.

When working with samples, which will be used in particularly sensitive tests, take into account the evaporation and condensation that may occur while the method is running.

Use filter tips for aggressive liquids. Also use filter tips for tasks which are sensitive to cross-contamination (aerosols) or when working with liquids which are prone to clot formation. In these cases, filter tips can prevent contamination of the pipetting heads.

The inner diameter of sample tubes, reagent vessels, etc. must be greater than the sleeve diameter of the pipetting head. For the 1000 μ l pipetting head, the inner diameter must be greater than 9mm. For the 5ml pipetting head, the inner diameter must be greater than 18mm.

Liquid Level Detection needs to be explicitly tested when working with foamy liquids. Foam may affect the accuracy of Liquid Level Detection.



ATTENTION

Never disable any safety measure.

1.7.1.6 Loading

Do not exchange positions of sample and reagent tubes, or switch micro-plates after they have been identified by the barcode reader. This could result in incorrect test data or instrument crash.

Microplates must be placed on the carrier such that well A1 is in the position defined in the deck layout of the method.

When pouring liquid into the containers, ensure that there is no foam on the surface of the liquid. Note that foam may cause pipetting problems.

Do not overfill reagent containers, tubes, or other liquid containers.

Do not mix tip size and type (e.g. with or without filter, or different volumes) in the same tip rack. Make sure to match the tip type to be used with the particular method. Take care when using tips which cannot be distinguished by the tip recognition feature (refer to [Section 2.1.3 Tip Recognition](#) and [Section 2.6 Tips and Needles](#)).

Do not fill up partially consumed tip racks with tips from another rack. Tip should be loaded into the tip racks as they are provided in the original package. They are individually labeled with a barcode for identification.

1.7.1.7 Work Routine

Do not try to open the front cover of the instrument during a run because the system will abort and this may cause a loss of data.

When the system is paused, do not wait too long before resuming the run. Loss of liquid from a full tip may result in invalid data.

Discard used tips. Do not reuse them.

Do not empty the tip waste during a run.

Do not leave tips on the pipetting channels for a long period of time (for example, overnight). This may cause damage to the CO-RE O-rings. A daily maintenance procedure will eject the tips.

1.7.1.8 Aseptic Applications

If used for aseptic processing, the ML STAR has to be installed in a grade A clean room with laminar airflow from the cleanroom ceiling according to EU-GMP Annex 1. The directed airflow from the ceiling to the bottom ensures the air barrier function of machine housings especially designed for the protection of the open processed pharmaceutical product. During operation, moving machine parts will guide the airflow in a different pattern through the housing. Very important is that the preliminary air flow direction stays in operation during the complete processing in order to prevent contamination due to backflow of air into the instrument housing.

The STAR liquid handling robot system fulfills the criteria for a successful media fill simulation for aseptic processing defined in the currently valid EU-GMP guideline Annex 1.

The performance of the clean room regarding microbiological contamination fulfills the defined requirements of the EU-GMP guideline Annex 1 for grade A areas.

The STAR fulfills the requirements of air cleanliness for aseptic areas grade A defined in EU-GMP Annex 1 and ISO Class 4 according to ISO 14644-1.

This means that the ML STAR can work aseptically in a sterile environment and does not present a risk of contamination for the environment or for the process.

1.7.2 Biohazard and Chemical Precautions

If the ML STAR instrument becomes contaminated with bio-hazardous or chemical materials, it should be cleaned in accordance with the maintenance procedures. The procedures are described in [Section 4 Maintenance](#) and [Section 5 ML STAR Instrument Decontamination](#). Observe and carry out the maintenance procedures given. Failure to do so may impair the reliability and correct functioning of the ML STAR.

If working with bio-hazardous samples, observe and carry out the maintenance procedures, paying particular attention to cleaning and decontamination. Wear gloves when handling the pipetting arm and channels, the carriers, racks, containers and tips.

Avoid touching tips discarded into the laboratory-supplied waste container. Any surfaces onto which liquid is spilled must be decontaminated.

Do not use disinfecting materials which contain hypochlorite (Javel water, Chlorox) or other bleaching fluids.

When working with bio-hazardous or chemical materials, the user must not touch them. The ML STAR will drop its used tips into a waste container, which should be emptied during the daily maintenance or as soon as it is full.

When using an exhaust suction device to remove toxic, aggressive or corrosive gases, make sure to place the device close to the source of gas or vapor in order to prevent contact of corrosives with ML STAR components, especially the pipetting heads.

1.7.3 Computer Precautions

Use the necessary precautions against software viruses. Use only manufacturer's original installation DVD/CD-ROM sets for the operating system. Use only the original Hamilton VENUS Software supplied on an installation USB Stick.

Running other software in parallel to the VENUS Software may negatively affect the operation of the ML STAR instrument.

Any manipulation of the VENUS Software data files or other information determining or affecting ML STAR functions can result in erroneous test results or instrument failure.

Only the VENUS Software may be used to control the ML STAR.

For reasons of data safety and integrity, the use of an Uninterrupted Power Supply (UPS) is recommended, since a loss of power may cause data to be lost or corrupted.

To avoid computer breakdowns, configure a hard disk of sufficient space in the computer. Ensure that there is always enough storage capacity on the hard drive. Delete log files from time to time. Generated data within the Log Files Directory (e.g. traces, TADM data and pipetting files) should be backed up onto the laboratory's host device and deleted from the control PC's hard disk at weekly intervals.

1.7.4 Electrical Safety Precautions

Before removing a mechanical or electrical component, the ML STAR must be switched off and disconnected from the main electricity supply and from the PC.

Every installation and de-installation of an electrically powered ML STAR component must be done by a Hamilton trained field service engineer.





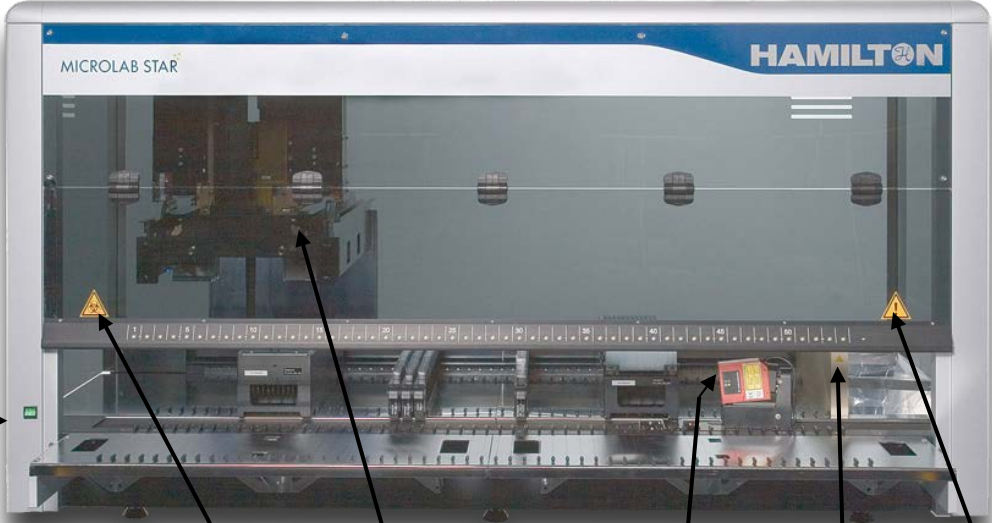

1.7.5 Hazards

The safety of personnel and equipment can only be ensured if the safety instructions and the safety-related warnings are strictly observed and followed.

The following section describes the main safety considerations in operating your Hamilton product and the main hazards involved.

Location and explanation of warning and attention labels:

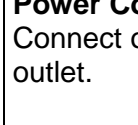
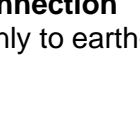
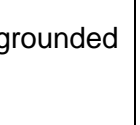

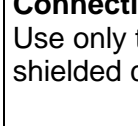
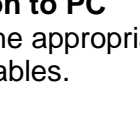
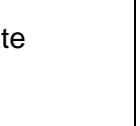
	Power Connection Connect only to earth-grounded outlet.		Connection to PC Use only the appropriate shielded cables.		USB Connection Having a total cable distance of more than 5m, signals loss can occur.		Laser Beam (Autoload) Do not stare into beam of class 2 laser of the barcode reader.
	Biohazard Warning Deck may contain bio-hazardous or chemically contaminated materials.		Biohazard Warning Waste may contain bio-hazardous or chemically contaminated materials.		Laser Beam (Tube Twister) Do not stare into beam of class 2 laser of the barcode reader.		Moving Parts Moving arm inside transparent cover. Aborts the run if the cover is opened.
	Pipetting Arm Do not move Pipetting Arm by hand.		Hot Surface Avoid contact with the HHS. Surfaces are hot and may cause personal injury if touched.				

1.7.5.1 Substance Related Hazards



ATTENTION

Chemical, biological and radioactive hazards can be associated with the substances used or the samples processed with the instrument. The same applies to waste disposal. The handling of substances and the disposal of waste may be subject to local, state or federal law or regulations with regard to health, environment or safety.

- *Always be aware of possible hazards associated with these substances*
- *Use appropriate protective clothing, goggles and gloves*
- *Strictly observe the corresponding provisions*



ATTENTION

Caustic substances can cause burns and eye injury.

- *Always be aware of possible hazards associated with these substances*
- *Avoid exposure to caustic substances*
- *Use appropriate protective clothing, goggles and gloves*



ATTENTION

Fire Hazard.

- *Use caution when using flammable materials. The instrument is not explosion protected nor for use in Ex zones.*

1.7.5.2 Safety Measures

- **Access to Power Switch/Power Cord**

Ensure there is enough room to access the power switch and power cord.

- **Working Area**

The safety concept assumes that the doors are always closed and locked during normal operation.

- **Surrounding Area**

Make sure the ventilation outlets of the instrument are not impaired by obstacles placed in the surrounding area.



ATTENTION

Rapid temperature changes or direct sunlight may affect certain functions such as barcode reading and pipetting accuracy.

- *Do not open windows next to the instrument*
- *Do not expose the instrument to direct sunlight or intense artificial light during operation*

Use appropriate:

Protective clothing



Goggles



and Gloves.



1.7.5.3 Loading Tray

Loading Tray:

- The instrument loading tray is a part of the instrument and must be treated with care



ATTENTION

Risk of damage to equipment. Leaning onto the instrument loading tray will lead to damage of the loading tray.

- Do not lean onto the loading tray.*



Foreign object damage:

- Make sure that the loading tray has been cleared from foreign objects before running the instrument
- Foreign objects may obstruct the instrument and lead to damage to the equipment

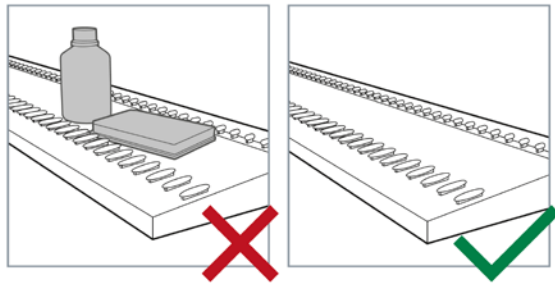

1.7.5.4 Holding Labware

Holding Labware:

- Hold microplates by its sides

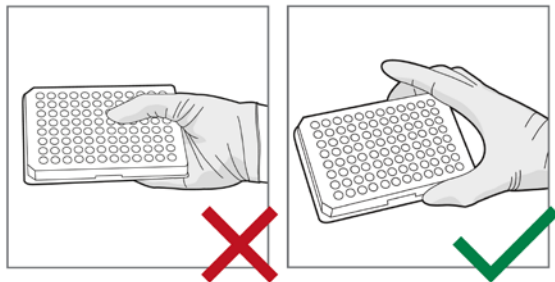

1.7.5.5 Holding Tubes

Holding Tubes:

- Avoid holding tubes on barcodes
- Hold the tubes as shown

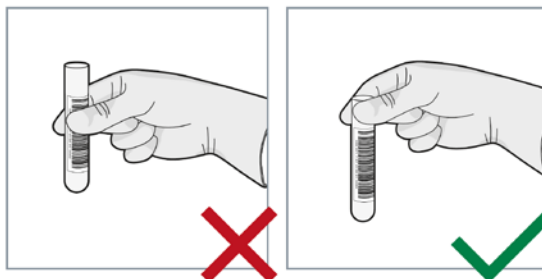

1.7.5.6 Placing Labware

Placing labware onto carriers:

- Make sure labware is placed onto the carrier correctly
- Incorrectly placed labware will lead to collision or malfunction

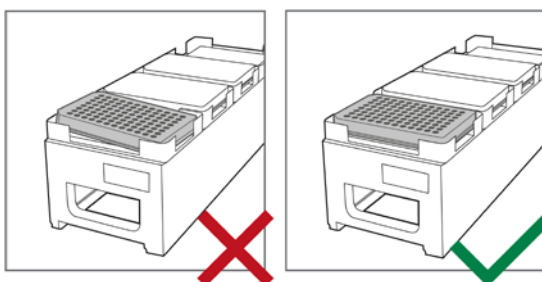

1.7.5.7 Loading Plate Carriers

Loading Plate Carriers:

- Make sure the carriers have been pushed to the mechanical stop of the instrument
- Incorrectly positioned carriers will lead to malfunctions or collision

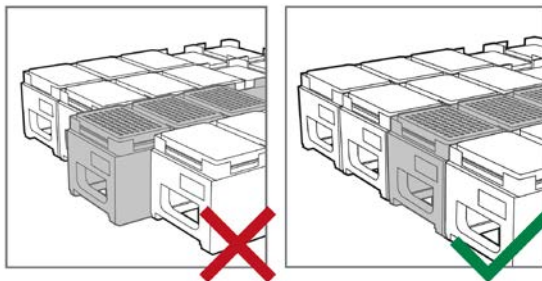

1.7.5.8 Loading Tube Carriers

Loading Tube Carriers:

- Make sure the tube carriers have been pushed to the mechanical stop of the instrument.
- Incorrectly positioned tube carriers will lead to malfunctions or collision.

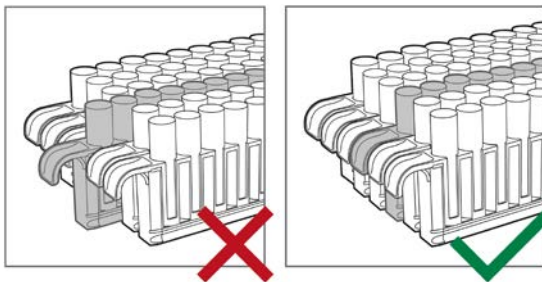

1.7.5.9 Barcodes Placement

Barcode quality:

- Make sure that all barcodes are readable as well as correctly applied
- Unreadable, scratched, smudged or incorrectly positioned barcodes on tubes will not be processed

Refer to the barcode types and quality requirements in [Section 7.29 Autoload Option: Barcode and Reader Specifications](#).

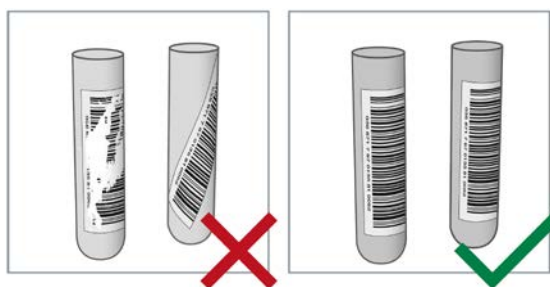

Barcode orientation:

- Make sure all tube barcodes have the correct orientation
- Incorrectly placed tube barcodes will not be readable

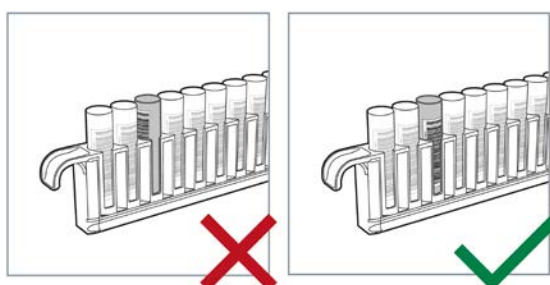

1.7.5.10 Tube Placement

Tube position:

When placing tubes into tube carriers:

- Make sure the tubes are pushed all the way down into the tube carrier
- Incorrectly placed tubes may lead to malfunctions

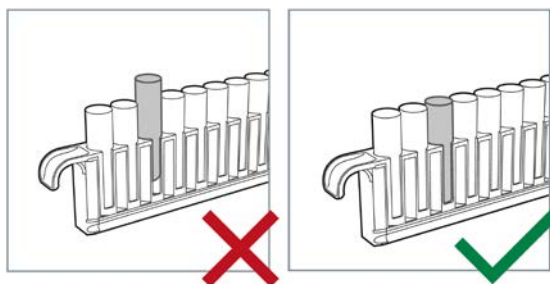

Tube height:

When placing tubes into tube carriers:

- Make sure that all tubes placed into the tube carrier are the same height
- Different tube heights will lead to incorrect calculation of sample volumes and lead to malfunctions

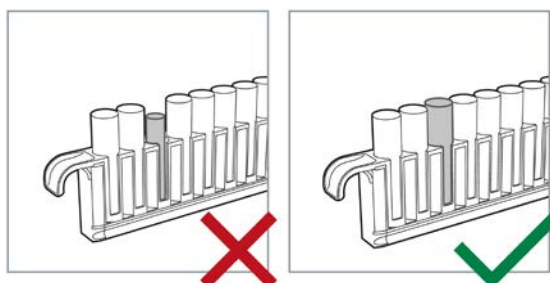

1.7.5.11 Labware Orientation

Labware orientation on carriers:

- Make sure plates have the correct orientation on the carrier
- The well position A1 has to be in the upper left

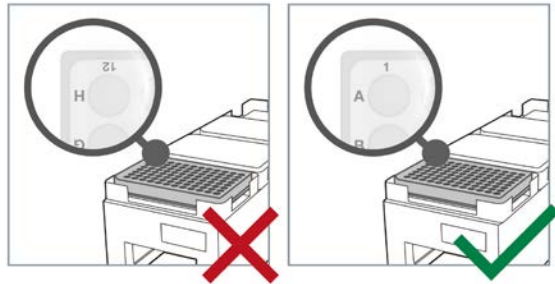

1.7.5.12 Trough Position

Placing troughs into trough carriers:

- Make sure the troughs are pushed all the way down into the carrier
- Incorrectly placed troughs will lead to spillage and/or malfunctions

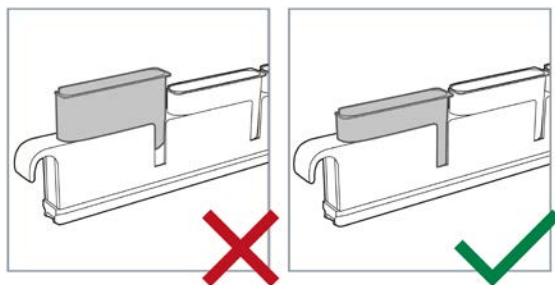

2. Description of the ML STAR

2.1 ML STAR

STAR is the Hamilton acronym for Sequential Transfer and Aliquoting Robot. The ML STAR is a robotic pipetting workstation used for pipetting liquid samples in automated processes.

Pipetting means transfer of small quantities of liquid from one container to another. A pipetting operation is achieved by aspirating (drawing) liquid from a source container, then transferring and dispensing (dropping) it into a target container.

2.1.1 The Air Displacement Pipetting Principle

The ML STAR instrument is based on the **air displacement pipetting** principle, comparable to the functionality of handheld pipettes. Air displacement means that the liquid is aspirated into and dispensed from a disposable tip or needle by the movement of a plunger. Between the plunger and the liquid surface is air. No system liquid of any kind is involved in the ML STAR.

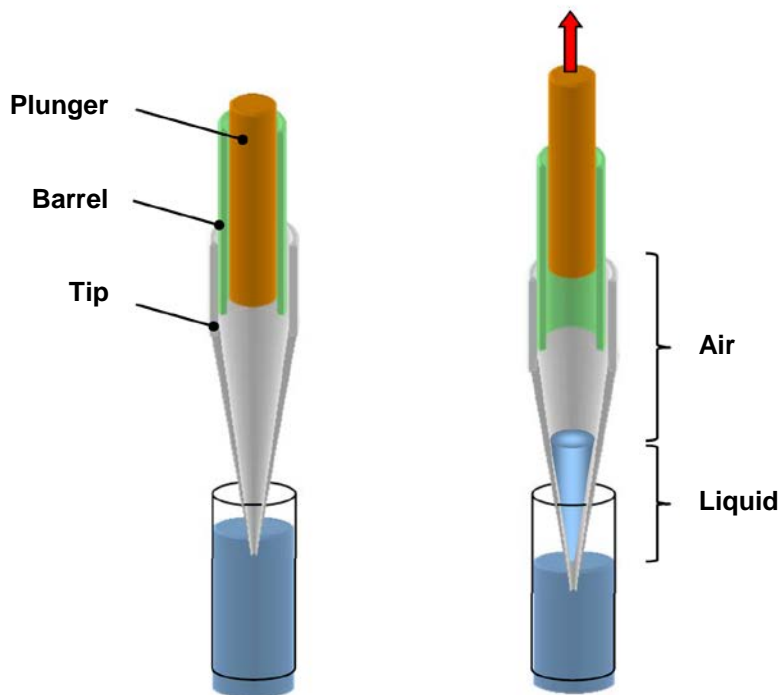

The air displacement pipetting principle



NOTE

Pipetting with the ML STAR is identical to pipetting with a handheld plunger pipette. The pipetting head's barrel and plunger are not intended to be cleaned. We recommend using filter tips when working with infectious agents such as viruses, etc.

2.1.2 Tip Pick-up with the CO-RE Technology

The first task for the ML STAR pipetting head is to pick up a Hamilton disposable tip or a reusable steel needle. Due to the unique CO-RE (Compression-induced O-Ring Expansion) technology, precise tip attachment and positioning is achieved. Tip alignment is critical for positioning the orifice of the tip at the proper height of the liquid for accurate pipetting as well as for locating the tip precisely within the horizontal plane of the labware. The annular groove design of the Hamilton tip allows exact seating of the locking O-ring within the tip for proper vertical and horizontal alignment. The system requires no vertical force for tip attachment or tip ejection, thus eliminating mechanical stress and improving overall system reliability along with pipetting speed and dexterity. CO-RE technology in combination with the use of Hamilton tips facilitates maximum pipetting accuracy and reliability and guarantees the published pipetting specifications.

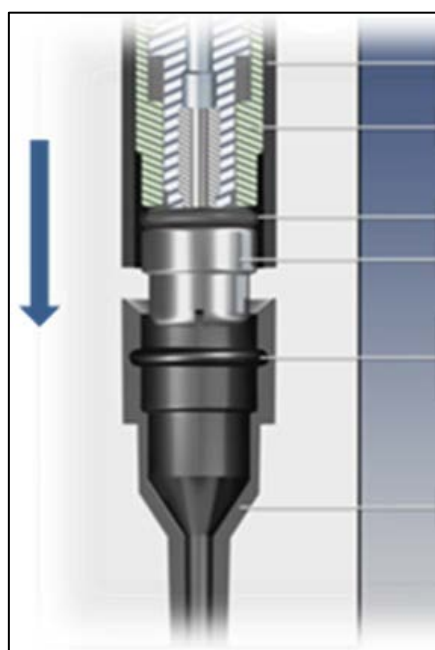

1. Tip Ejection Sleeve
2. Pressure Sleeve
3. O-Ring (unsqueezed)
4. Stop Disk
5. Groove for the O-Ring Expansion



6. Disposable Tip

Patent Numbers: EP11712400B2 (CH, DE, FR, GB) US7033543
 DE199117375 US2006233669
 JP3977597

Hamilton pipetting channels and CO-RE tips are designed to fit precisely into each other for maximum O-ring and tip life. The annular groove of the Hamilton tip ensures a proper seal between the tip and the pipette channel. This is important for pressure sensing which the pipettor uses for liquid level detection, anti-droplet control as well as proper aspiration and dispense monitoring and validation. Hamilton tips are dropped off by relaxing the O-ring and allowing gravity to pull the tip down. This way tips are gently released into the waste area minimizing the danger for liquid remaining on the tips to become airborne and to contaminate the pipetting workspace.

**NOTE**

The principle of the CO-RE technology has the following advantages:

- Enables coupling of disposable tips or washable needles within the same run
- Allows use of different sizes of tips on the same pipetting head in the same run
- Picking up a gripper and other tools is possible with a pipetting channel
- Prevents aerosols upon tip ejection





**ATTENTION**

Only Hamilton CO-RE tips and needles should be used for coupling to the pipetting heads of the ML STAR instrument. Other tips may cause contaminated or damaged pipetting channels and may lead to erroneous results.

CO-RE technology is used on all Hamilton pipetting channels, including CO-RE 96 and 384 Probe Head.

2.1.3 Tip Recognition

The tips used in a pipetting procedure must be matched with the suitable pipetting channel or pipetting head in order to prevent damage to the device. Therefore the ML STAR instruments offer two ways to automatically recognize the tip type used. All tip racks have color-coded barcode labels for automated recognition. The color helps distinguishing the tip volume by eye. The text on the barcode label enables a distinct identification by eye.

Tip volume	Barcode label	Color code
10µl		light orange
50µl		light red
300µl		yellow
1000µl		white
5000µl		green

2.1.3.1 Tip Recognition using the Autoload Function

The Autoload (see [Section 2.4.17 Autoload Option](#)) includes a barcode reader which identifies the barcodes on the tip racks. Barcodes of tip racks are read automatically when loading tips and the risk of mixing up tip types is excluded. This method is suitable for all tip types, regardless of the pipetting tools to be used.



Tip carrier with five bar-coded tip racks loaded

2.1.3.2 Tip Recognition using the VENUS Tip Type Recognition Feature

The VENUS Software offers a tip type recognition feature for 1000 μ l-pipetting channels, based on the different tip geometries and independent from barcode (please refer to the [Microlab STAR Programmer's Manual](#)). It is available for both, disposable tips and needles and it is activated during installation by the Hamilton trained field service engineer. This feature increases the instrument's safety when no Autoload is used and when different tip types are used.

For distinguishing disposable CO-RE tips, 50 μ l and CO-RE tips, 300 μ l, a special library is needed. Please consult a local Hamilton representative.

Slim tips 300 μ l cannot be distinguished from CO-RE tips 1000 μ l by the tip type recognition feature. We recommend using the Autoload for tip loading in this case and in any case to implement a visual check to be sure.

2.1.4 Liquid Level Detection: LLD

The liquid level of the container to be aspirated from can be detected. This can be provided by ML STAR's Liquid Level Detection (LLD) feature, based on either capacitive (cLLD) or pressure (pLLD) signal detection. Normally capacitive LLD is used for conductive liquids. The sensitivity of the capacitive LLD that is to be used depends on the vessel size, volume and the conductivity (or polarity) of the liquid to be detected.

For non-conductive liquids, or in case of an insufficient coupling between container bottom and carrier, pressure LLD is used. Pressure LLD only works with new and empty tips for the aspiration of liquids. The pLLD is available on the individual pipetting channels only.

In case of detecting under demanding circumstances (e.g. foaming liquids), the capacitive and the pressure Liquid Level Detection can be used at the same time.

**NOTE**

We recommend always using a defined sensitivity, such as 'low', 'medium', 'high' or 'very high'. If the value in the labware is 'Off' it causes bad results.

When selecting 'very high' all of the time, liquid may be detected in a wrong position, cLLD can, for example, be triggered by vapor of volatile liquids or by foam.

**ATTENTION**

Liquid Level Detection needs to be explicitly tested when working with foamy liquids. Foam may affect the accuracy of liquid level detection.

- The liquid must be conductive so that dual LLD can be utilized.
- The tolerance between the first and last allowable detection must be defined empirically.
- Then the immersion depth value has to be defined large enough to ensure that the tip is located below the foamy layer before aspiration. This requires some test runs as well. The starting point of the immersion depth is where both LLD's are triggered.

2.1.5 Monitored Air Displacement: MAD

The ML STAR is equipped with an aspiration monitoring feature. During the aspiration process, the pressure within the pipetting channel is measured in real time. Analyzing the shape of the $p(t)$ curve, the system can distinguish the following situations:

- A correct aspiration takes place
- Air is aspirated into the tip (because, for example, the container has not been filled properly)
- A clot blocks the tip

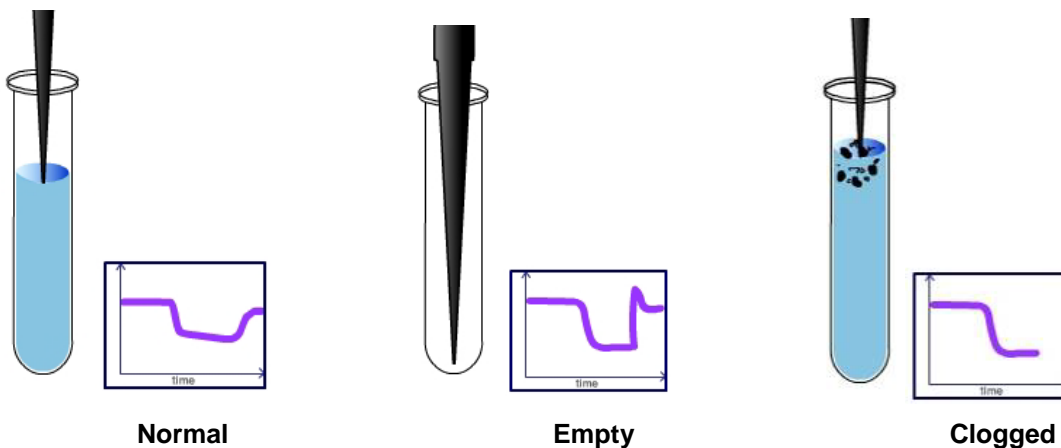

Aspiration monitoring based on pressure.

The Monitored Air Displacement feature is available on the individual pipetting channels only. The diagram shows the functioning of Monitored Air Displacement based on pressure.

2.1.6 Capacitance-Based Clot Detection

In addition to pressure-based clot detection, the ML STAR is equipped with capacitance-based clot detection. This detection approach works in the case of aspiration with capacitance Liquid Level Detection switched on. The system measures the conductive signal when the tip leaves the liquid after aspiration. Due to the air gap between the tip and the liquid, the capacitance signal will vanish once a given height is reached. If a clot is present, it bridges the distance and the signal will remain, resulting in an error message. This clot detection is independent of pressure-based monitoring.

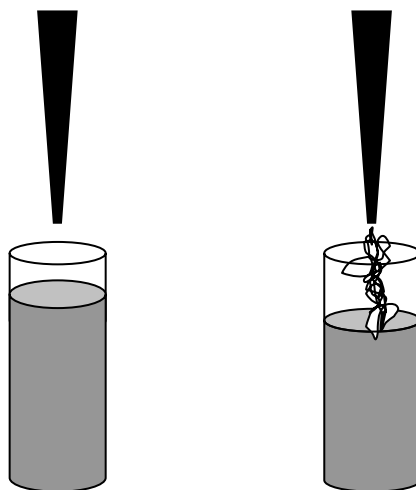

2.1.7 Anti-Droplet Control: ADC

Does the application require pipetting of volatile solvents? The Anti-Droplet Control (ADC) enables doing this with highest process safety. In conventional pipettes the high evaporation pressure of volatile solvents causes immediate dripping from the tip. The ML STAR uses Monitored Air Displacement Technology and can therefore detect pressure changes following aspiration and compensate for them in real time.

The principle is shown in the illustration on the next page: as the evaporation causes a pressure increase (red) the pipetting unit detects the changes and compensates for them with plunger movements (blue). The liquid remains in the tip.

The Anti-Droplet Control (ADC) has to be activated in the 'HSLML_STARLib' command library of the VENUS Software. It is available on the individual pipetting channels only.



ATTENTION

Use ADC only when pipetting liquids that ask for this mode.

There are two reasons that make a continuous use of ADC not practical. First, one might run into a position in which the plunger is no more able to handle the upcoming pressure difference and will therefore trigger an error. The second reason is that there might be a pressure interference which cannot be compensated by the plunger while the instrument is not pipetting.

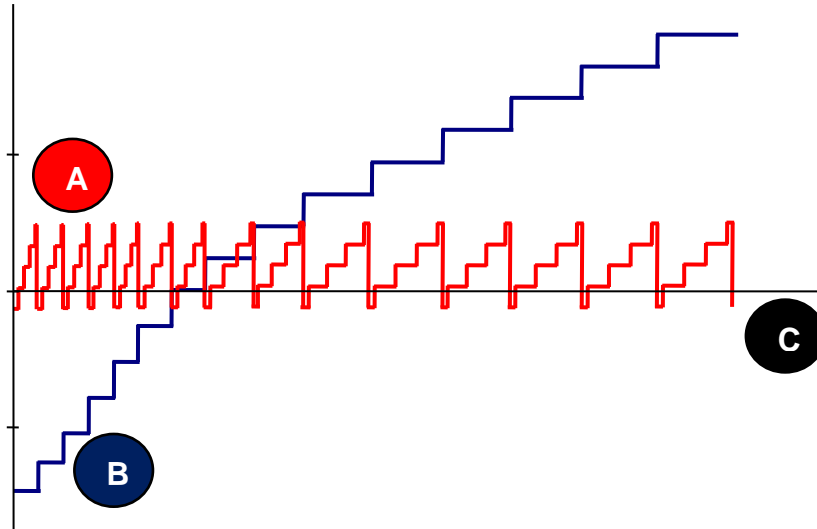

A. Pressure (red) **B. Plunger movement (blue)** **C. Time**

Patent Numbers: EP1614468B1 (AT, BE, CH, DE, ES, US7681660
FR, GB, IE, IT, NL, SE)

2.1.8 Total Aspiration and Dispensing Monitoring: TADM

During crucial sample transfers, the ML STAR can monitor aspiration and dispense steps in real time. TADM verifies that a sample has been transferred by using a traceable digital audit trail. The function of TADM is a software option and therefore not available by default.

TADM is available for individual pipetting channels and with the CO-RE 96 Probe Head 1000µl TADM.

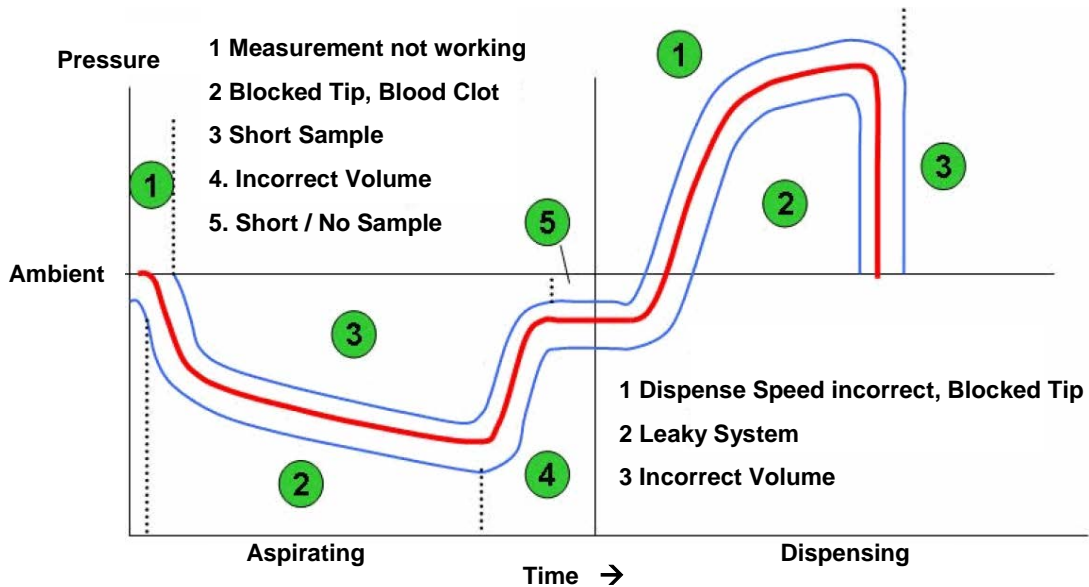

Patent Numbers: EP1412759B1 (BE, AT, CH, DE, ES, FR, HK1067407
GB, IE, IT, NL, SE) US6938504
JP4328531

2.1.9 Availability of Technologies on the Pipetting Tools

The following table provides an overview of individual technologies available with the various pipetting tools.

Pipetting Tool	Technology	CO-RE	cLLD	pLLD ¹⁾	MAD	TADM	ADC
1000µl-Pipetting Channel		✓	✓	✓	✓	✓ ²⁾	✓
5ml-Pipetting Channel		✓	✓	✓	✓	✓ ²⁾	✓
CO-RE 96 Probe Head		✓	✓ ³⁾	-	-	-	-
CO-RE 96 Probe Head TADM		✓	✓ ³⁾	-	-	✓ ²⁾	-
CO-RE 384 Probe Head		✓	✓ ⁴⁾	-	-	-	-

¹⁾ Available only for use with new disposables; not available for needles

²⁾ Available with VENUS ONE TADM FEATURE (P/N 911099)

³⁾ Available on channels A1 and H12

⁴⁾ Available on channels A5 and P24

2.2 Platforms

The ML STAR instrument work surface, called a “deck”, for placing loadable carriers is available in three different sizes. These carriers hold reagent containers, such as tubes, microplates and other kinds of labware.

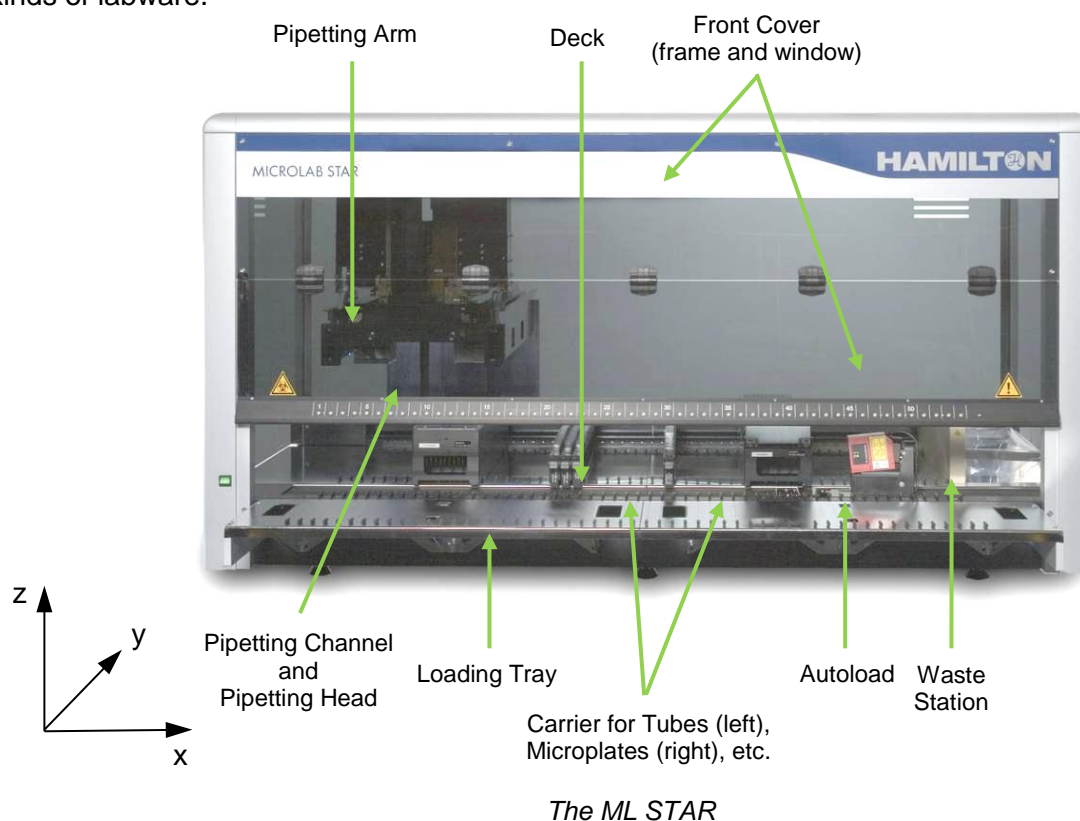

The instrument is fully covered by acrylic glass covers. The front cover consists of a hinged transparent window made of acrylic glass. This window is equipped with a magnetic switch that is monitored during a run. Opening the cover will abort the running method.



ATTENTION

An aborted running method (stopped by opening the front cover) cannot be restarted. For opening the window during a run, click [Pause] in the run screen, wait until the instrument stops and then open the front cover.

The instrument deck is divided into equal tracks (T) for loading carriers in pre-determined positions. This eliminates the need for precise measurement of positions. The deck has partitions of 22.5mm, which is equivalent to 1-T (track). The labware carriers are adapted to these partitions (e.g. 1-T carriers for sample tubes or 6-T carriers for microplates or CO-RE tips, etc). An additional partition provides space for the tip waste container.

The instrument's internal coordinate system is shown in the picture above, located at its origin.



NOTE

The ZERO position is 100mm below the deck work surface.

A Touch Screen Monitor is available and can be attached to the right side of the ML STAR instrument. It is the perfect interface to start methods, enter data and to make decisions during runtime. For ergonomic reasons, it is recommended to use a desktop computer with monitor, keyboard and mouse for extended programming work.

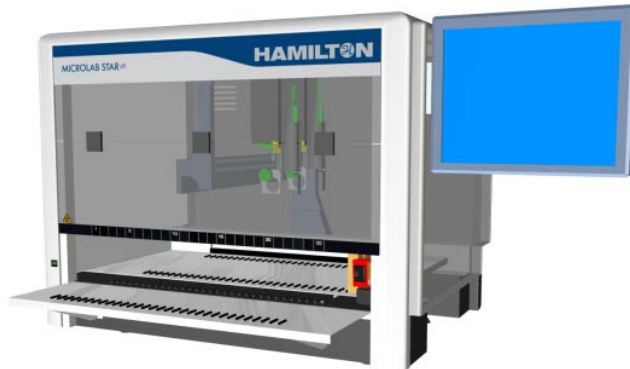

2.2.1 ML STARlet

The compact version of the ML STAR is called ML STARlet. The ML STARlet is the ML STAR instrument with the smallest deck width for loading carriers. The deck has partitions for a maximum of 30 1-T carriers for sample tubes, or a maximum of five 6-T carriers for microplates and CO-RE tips. This means that a total of 25 SBS (Standard format of the Society for Biomolecular Screening) positions can be placed onto a ML STARlet deck.



ML STARlet

2.2.2 ML STAR

The ML STAR's deck is divided into 54 equal tracks (T) for loading carriers in predetermined positions. The deck has partitions for a maximum of 54 1-T carriers for sample tubes, or a maximum of nine 6-T carriers for microplates and CO-RE tips. This means that a total of 45 SBS (Standard format of the Society for Biomolecular Screening) positions can be placed onto a ML STAR deck.



ML STAR

2.2.3 ML STARPlus

The large version of the ML STAR is called ML STARPlus. If equipped with a full deck extension, the ML STARPlus has a deck divided into 71 equal tracks for loading carriers. The deck has partitions for a maximum of 71 1-T carriers for sample tubes, or a maximum of eleven 6-T carriers for microplates and CO-RE tips. This means that a total of 55 SBS (Standard format of the Society for Biomolecular Screening) positions can be placed onto a ML STARPlus deck.



ML STARPlus

The ML STARPlus is the compact ML STARlet extended on site by additional workspace. The workspace can be filled by additional tracks. The other possibility is to integrate 3rd party devices, such as readers, washers, centrifuges, etc. The extension part of the ML STARPlus is available in 3 versions:

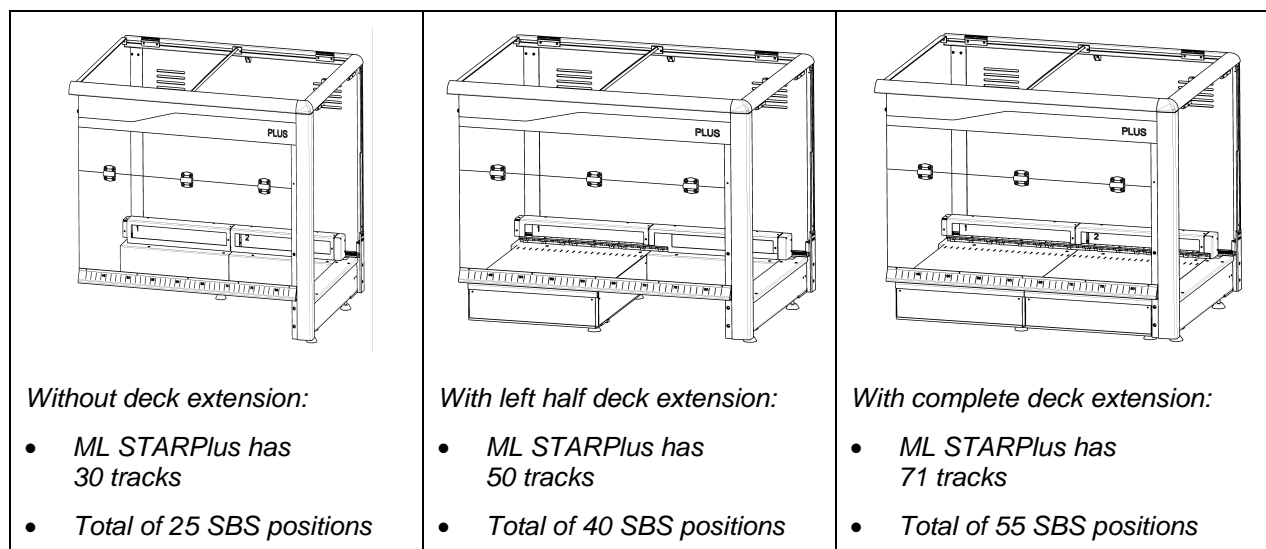

2.3 Pipetting Arm Configurations

The ML STAR offers a selection of a variety of arms, depending on the pipetting units and plate handling modules chosen. The pipetting arm moves in the x-direction. Whenever higher throughput is required, it is possible to have two arms on the system working in parallel. For instance, while one arm is reserved for the pipetting tasks, the other can transfer plates on the deck or to/from a peripheral device. There are further channel-based tools which can be mounted on the respective arms. Some example configurations are given below.

2.3.1 Modular Pipetting Arm

The Modular Pipetting Arm typically contains a set of pipetting channels, which work independently. It can be equipped with: up to 16 pipetting channels with 1000 μ l pipetting heads, up to 8 XL pipetting channels with 5ml pipetting heads, a plate handling tool (iSWAP), a tube handling tool and an imaging channel.

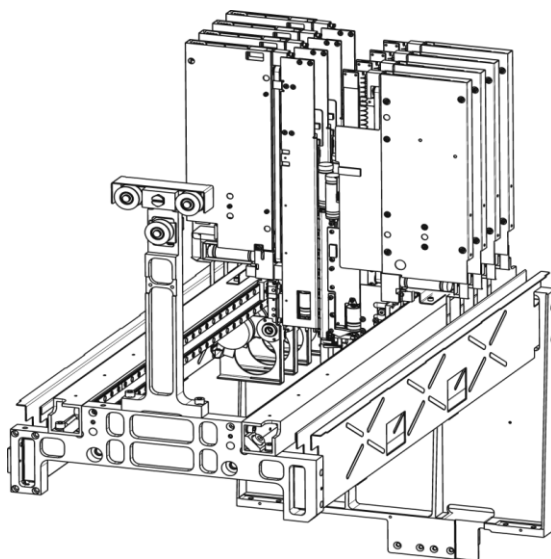

Modular Pipetting Arm

A possible configuration including all the tools is: 6 pipetting channels with 1000 μ l pipetting heads, 2 XL pipetting channels with 5ml pipetting heads, the tube handler, the imaging channel, with or without the plate handling tool (iSWAP).

The minimum distance between 2 - 1000 μ l pipetting channels on this arm is 9mm.

The minimum distance between 2 - 5ml XL pipetting channels on this arm is 18mm.

2.3.2 Modular Pipetting Arm MPH

The Modular Pipetting Arm MPH may hold: 1 CO-RE Multi Probe Head (CO-RE 96 Probe Head, a CO-RE 96 Probe Head TADM or a CO-RE 384 Probe Head) as an option paired with up to 12 pipetting channels with 1000 μ l pipetting heads, up to 8 XL pipetting channels with 5ml pipetting heads, a plate handling tool (iSWAP), a tube handling tool and an imaging channel.

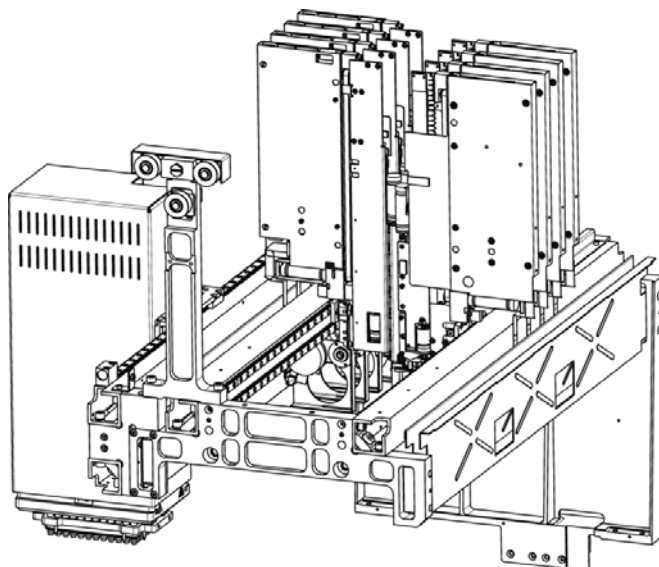

Modular Pipetting Arm MPH

A possible configuration including all the tools is: 1 CO-RE Multi-Probe Head (CO-RE 96 Probe Head, CO-RE 96 Probe Head TADM or CO-RE 384 Probe Head), 6 pipetting channels with 1000 μ l pipetting heads, 2 XL pipetting channels with 5ml pipetting heads, the tube handler, the imaging channel, with or without the plate handling tool (iSWAP).

The minimum distance between 2 - 1000 μ l pipetting channels on the modular pipetting arm MPH is 9mm.

The minimum distance between 2 - 5ml XL pipetting channels on the modular pipetting arm MPH is 18mm.

2.3.3 Pipetting Arm MPH/iSWAP

The Pipetting Arm MPH/iSWAP is fitted with: 1 CO-RE Multi Probe Head (CO-RE 96 Probe Head, a CO-RE 96 Probe Head TADM or a CO-RE 384 Probe Head) on the left. The right side of this arm can be equipped with up to 8 pipetting channels with 1000 μ l pipetting heads, up to 4 XL pipetting channels with 5ml pipetting heads, a plate handling tool (iSWAP), a tube handling tool and an imaging channel.

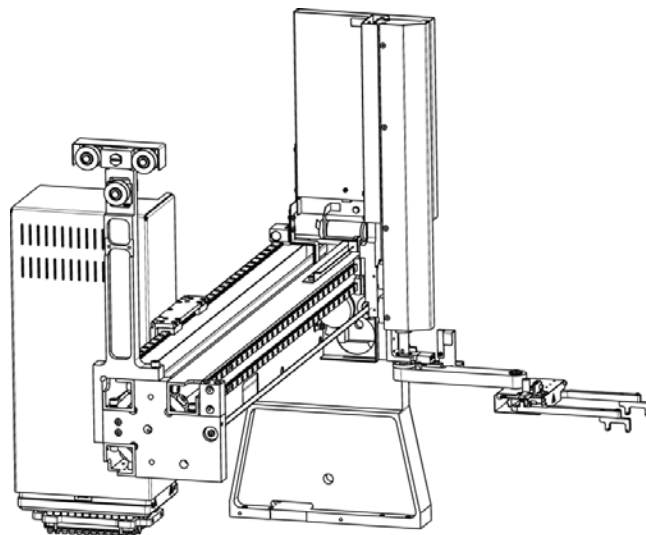

Pipetting Arm MPH/iSWAP

A possible configuration including all the tools is: 1 CO-RE Multi Probe Head (CO-RE 96 Probe Head, CO-RE 96 Probe Head TADM or CO-RE 384 Probe Head), 2 pipetting channels with 1000 μ l pipetting head, 1 XL pipetting channel with a 5ml pipetting head, the tube handler, and the imaging channel, with or without the plate handling tool (iSWAP).

The minimum distance between 2 - 1000 μ l pipetting channels on the pipetting arm MPH/iSWAP is 18mm.

The minimum distance between 2 - 5ml XL pipetting channels on the pipetting arm MPH/iSWAP is 36mm.

2.3.4 Pipetting Arm MPH

The Pipetting Arm MPH is equipped with: 1 CO-RE Multi Probe Head (CO-RE 96 Probe Head, CO-RE 96 Probe Head TADM or CO-RE 384 Probe Head).

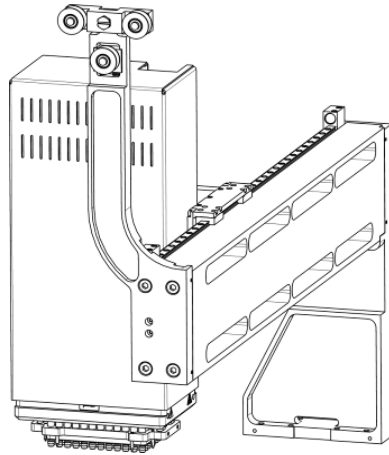

Pipetting Arm MPH

2.3.5 iSWAP Arm

The iSWAP Arm is typically fitted with the iSWAP for dual-arm configurations. This arm can be equipped with up to 8 pipetting channels with 1000 μ l pipetting heads, up to 4 XL pipetting channels with 5ml pipetting heads, a plate handling tool (iSWAP), a tube handling tool and an imaging channel.

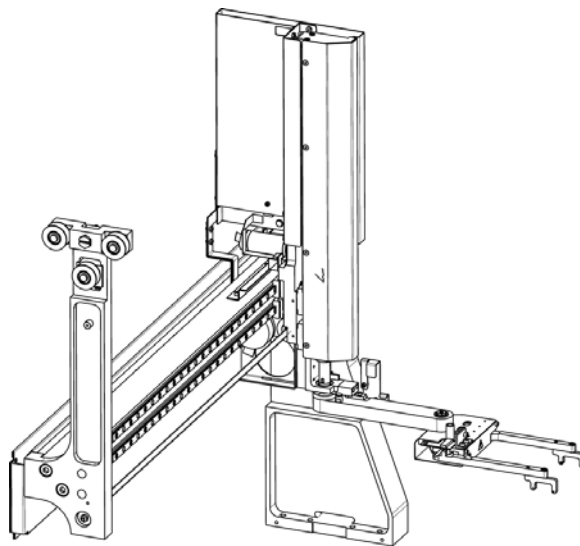

iSWAP Arm

A possible configuration including all the tools is: 2 pipetting channels with 1000 μ l pipetting heads, 1 XL pipetting channel with a 5ml pipetting head, the tube handler, the imaging channel, with or without the plate handling tool (iSWAP).

The minimum distance between 2 - 1000 μ l pipetting channels on the iSWAP arm is 18mm.

The minimum distance between 2 - 5ml XL pipetting channels on the iSWAP arm is 36mm.

2.3.6 Dual-Arm Configurations

When higher throughput is required, it is possible to equip the ML STAR with two arms working in parallel. The preferred platform for dual-arm configurations is the ML STARPlus. The following examples show some typical dual arm configurations. Several other combinations are possible.

2.3.6.1 Dual Arm Assay Workstation 8+iSWAP

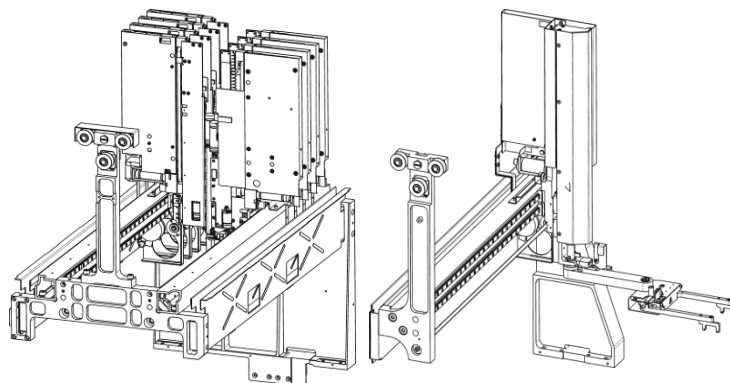

Modular Pipetting Arm with 8 Pipetting Channels combined with the iSWAP Arm

This workstation, for instance, makes sense if the sample preparation task (processed by the 8-pipetting channels) is isolated from the assay tasks (such as incubation tasks, plate washing tasks, analyzing tasks, etc). The iSWAP is used to transfer the processed microplate to/from the 3rd party equipment such as a reader, incubator, plate washer, etc.

2.3.6.2 Dual Arm Assay Workstation, 96+iSWAP

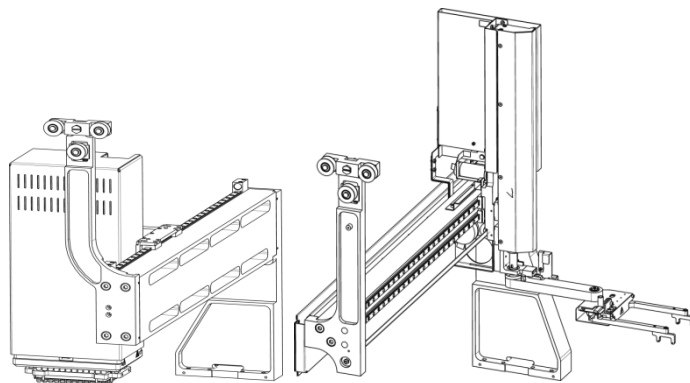

Pipetting Arm 96 with the CO-RE 96 Probe Head combined with the iSWAP Arm

This workstation, for instance, makes sense if the pipetting tasks (plate copy, plate reformation, serial dilution) take part in the format of microplates only, and the assay needs no further pipetting steps. In addition, plate transfer to and from other devices is required.

2.3.6.3 Dual Arm Assay Workstation 8+96/iSWAP

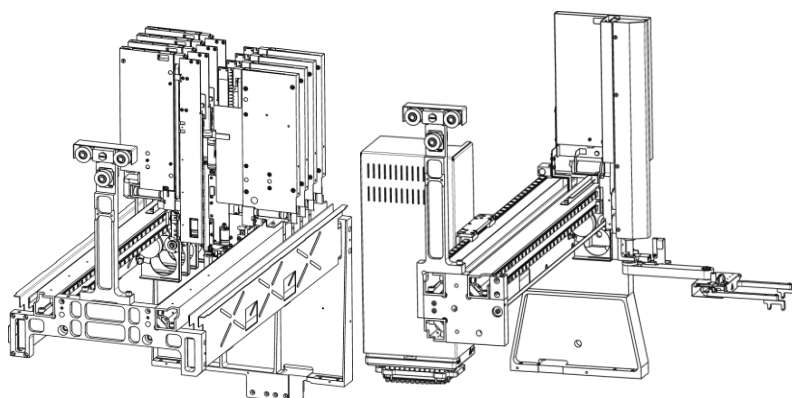

Modular Pipetting Arm with 8 Pipetting Channels combined with a 96/iSWAP Arm

This workstation, for instance, makes sense if the sample preparation task (processed by the 8-pipetting channels) is isolated from the assay tasks (as incubation tasks, plate washing tasks, analyzing tasks, etc). The assay task needs pipetting in the pattern of the CO-RE 96 Probe Head (one volume per plate, row or column). The iSWAP is used to transfer the processed microplate to and from 3rd party equipment, such as a reader, incubator, plate washer, etc.

2.4 Options and Upgrades

Options are defined as components or configurations that are part of the instrument. Predefined options are as follows: Manual load or Autoload, the type and quantity of pipetting arms, the quantity of pipetting channels, from 1 to 16 maximum for 1000 μ l pipetting channels or 1 – 8 maximum for 5ml pipetting channels, 1 CO-RE Multi Probe Head, (the CO-RE 96 Probe Head, CO-RE 96 Probe Head TADM, CO-RE 384 Probe Head), the plate handling tool (iSWAP), the tube handling tool and the imaging channel.

Accessories include assemblies such as wash stations, temperature controlled carrier, vacuum system, labware carrier, etc.

Pipetting channels, a CO-RE Multi Probe Head and accessories may be ordered as an option for new installation, or added as upgrades to an existing instrument.

The instrument's configuration is set within the configuration editor of the VENUS Software by a Hamilton trained field service engineer.



NOTE

An option may require a library, labware definitions etc. for use with the VENUS software. Please consult a local Hamilton representative.

2.4.1 1000µl-Pipetting Channels

The ML STAR comes with 1 to 16 pipetting channels working in parallel for simultaneous transfer of liquids. Each pipetting channel moves independently on the y-axis, as well as on the z-axis. Each pipetting channel uses its own high-precision motors and electronics to reach any position on the deck without the need of teaching.

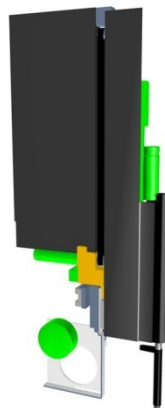

The 1000µl-pipetting channels support pipetting with disposable tips or with needles.







The following table gives an overview of disposable tips which can be used with the 1000µl-pipetting channels. Other combinations may be possible, but require special attention.























NOTE

If a type of tip is not shown, it cannot be used for that purpose.

See [Section 8.2 Ordering Information](#) for a complete listing.

1000µl-Pipetting Channel	Tips for Working Volume and Purpose					
Plate Type	10µl CO-RE Tip	50µl CO-RE Tip	300µl CO-RE Tip	1000µl CO-RE Tip	250µl Robotic Piercing Tip	300µl Slim Tip
 96-Well						

1000µl-Pipetting Channel	Tips for Working Volume and Purpose					
Plate Type	10µl CO-RE Tip	50µl CO-RE Tip	300µl CO-RE Tip	1000µl CO-RE Tip	250µl Robotic Piercing Tip	300µl Slim Tip
 <p>96-Well</p>						
 <p>96-Well Archive</p>						
 <p>384-Well Archive</p>						
 <p>1536-Well</p>						

The minimum distance between 2 - 1000µl-pipetting channels on the modular pipetting arms is 9mm, on all other arms it is 18mm.

The 1000µl-pipetting channels have a set “traverse height” of 245mm above the origin, or 145mm between the top of the disposable tip and the deck of the instrument. This means that when a pipetting channel moves from one location to another, it automatically does so at this height. This is a safety precaution to prevent the pipetting channels from colliding with items on the deck.

Instruments with 4, 8, or 16 pipetting channels are best operated with carriers holding microplates and tip racks in landscape orientation, whereas carriers with portrait orientation for microplates and tips are best suited for an instrument with 12 - 1000µl-pipetting channels.

The following table gives an overview of carriers and modules which can be used with the 1000µl-pipetting channels. Other combinations may be possible, but require special attention.









NOTE

If a type of carrier or module is not shown, it cannot be used for that purpose.

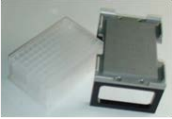
See [Section 8.2 Ordering Information](#) for a complete listing.

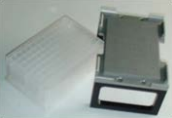
1000µl-Pipetting Channel	Carriers and Modules			
 <p>96-Well</p>	 <p>Plate Carrier for 96/384 Well Plates</p> <p>or</p>  <p>Deep Well Plates</p>	 <p>MFX DWP Nested</p> <p>or</p>  <p>MFX MTP Nested</p>	 <p>Plate Carrier for 1536-Well Plates</p>	 <p>Multiflex MTP Module</p> <p>or</p>  <p>Multiflex DWP Module</p>
 <p>96-Well Archive</p>	 <p>Plate carrier for Deep Well Plates</p>	 <p>MFX DWP Nested</p> <p>or</p>  <p>MFX MTP Nested</p>		 <p>Multiflex DWP Module</p>
 <p>384-Well</p>	 <p>Plate Carrier for 96/384 Well Plates</p> <p>or</p>  <p>Deep Well Plates</p>	 <p>MFX DWP Nested</p> <p>or</p>  <p>MFX MTP Nested</p>	 <p>Plate Carrier for 1536-Well Plates</p>	 <p>Multiflex MTP Module</p> <p>or</p>  <p>Multiflex DWP Module</p>

1000µl-Pipetting Channel	Carriers and Modules			
 <p>384-Well Archive</p>	 <p>Plate Carrier for Deep Well Plates</p>	 <p>MFX DWP Nested</p> <p>or</p>  <p>MFX MTP Nested</p>		
 <p>1536-Well</p>		 <p>MFX DWP Nested</p> <p>or</p>  <p>MFX MTP Nested</p>	 <p>Plate Carrier for 1536-Well Plates</p>	

An instrument equipped with 1 to 8 1000µl-pipetting channels on the modular arm has the full "random access space", which is the area where any of the 1000µl-pipetting channels are able to reach. For a 12 or 16 1000µl-pipetting channel equipped instrument, the "random access space", is reduced.

As shown in the screenshot below, the "random access space" of the different numbers of 1000µl-pipetting channels is indicated by lines at the left and right side of the deck layout of the VENUS Software:

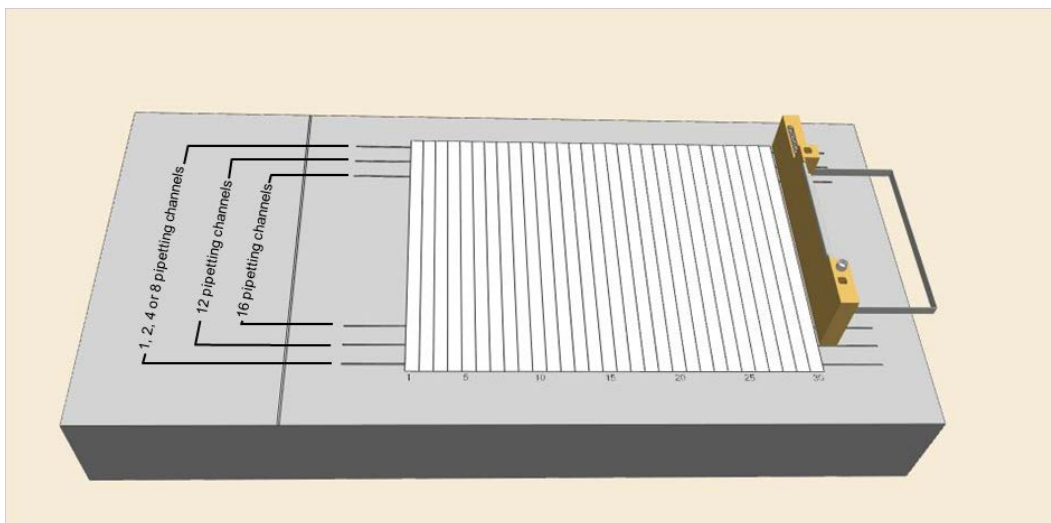

To guarantee random access to sample tube carriers, only the inner tube positions should be used. The number of blank positions in front and rear, to be used for the different number of 1000µl-

pipetting channels and the different tube carriers, is listed in the following table. The deck layout shows the relevant carriers directly above the columns of the table in each case.



NOTE

If pipetting positions outside the access space of the instrument are used, the system reports an error. However, a strictly batch-type process can eliminate these problems.

Low-volume tips do not reach the deck, even at the lowest z-position of the pipetting channel.

2.4.2 5ml-Pipetting Channels

The ML STAR instrument comes with 1 to 8 5ml-pipetting channels working in parallel for simultaneous transfer of liquids. Each 5ml-pipetting channel is moved independently on the y-axis, as well as on the z-axis. Each 5ml-pipetting channel uses its own high-precision motors and electronics to reach any position on the deck without the need of teaching.

The 5ml-pipetting channels support pipetting with disposable tips.

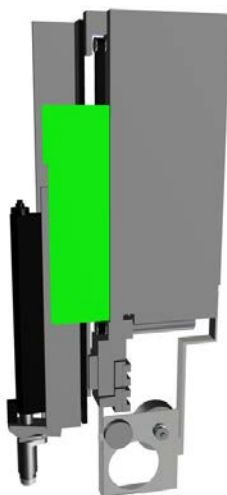







The following table gives an overview of disposable tips which can be used with the 5ml-XL pipetting channels. Other combinations may be possible, but require special attention.



NOTE

If a type of tip is not shown, it cannot be used for that purpose.

See [Section 8.2 Ordering Information](#) for a complete listing.

5ml-Pipetting Channel	Tips for Working Volume and Purpose	
	5ml Tip with Filter	5ml Tip without Filter
 <p>96-Well</p>	 <p>CO-RE Tip with Filter, 4000µl</p>	 <p>CO-RE Tip without Filter, 5000µl</p>
 <p>96-Well Archive</p>	 <p>CO-RE Tip with Filter, 4000µl</p>	 <p>CO-RE Tip without Filter, 5000µl</p>

The minimum distance between 2 - 5ml-pipetting channels on the modular pipetting arms is 18mm, on all other arms it is 36mm.

The 5ml-pipetting channels have a set traverse height of 245mm above the origin, or 145mm between the top of the disposable tip and the deck of the instrument. This means that, when a channel moves from one location on the deck to another, it automatically does so at this height. This is a safety precaution in order to prevent the 5ml-pipetting channels from colliding with items on the deck.

Instruments with 4 or 8 5ml-pipetting channels are best operated with carriers holding micro-plates and tip racks in landscape orientation, whereas carriers with portrait orientation for micro-plates and tips are best suited for an instrument with 6 - 5ml-pipetting channels.











The following table gives an overview of carriers and modules which can be used with the 5ml-pipetting channels. Other combinations may be possible, but require special attention.

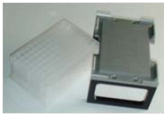
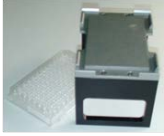

NOTE

If a type of carrier or module is not shown, it cannot be used for that purpose.

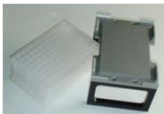
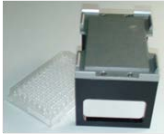
See [Section 8.2 Ordering Information](#) for a complete listing.

5ml-Pipetting Channel	Carriers and Modules			
 <p>96-Well</p>	 <p>Plate Carrier for 96/384 Well Plates or</p>  <p>Deep Well Plates</p>	 <p>MFX DWP Nested or</p>  <p>MFX MTP Nested</p>	 <p>Plate Carrier for 1536-Well Plates</p>	 <p>Multiflex MTP Module or</p>  <p>Multiflex DWP Module</p>
 <p>96-Well Archive</p>	 <p>Plate Carrier for Deep Well Plates</p>	 <p>MFX DWP Nested or</p>  <p>MFX MTP Nested</p>		 <p>Multiflex DWP Module</p>

An instrument equipped with 1 to 4 5ml-pipetting channels on a modular arm has the largest "random access space" which is the area, where any of the 5ml-pipetting channels is able to reach. For a 6 or 8 5ml-pipetting channel equipped instrument, the "random access space" is reduced.

The "random access space" of the different numbers of 5ml-pipetting channels is indicated by lines at the left and right side of the deck layout of the VENUS Software, as shown in the screenshot below:

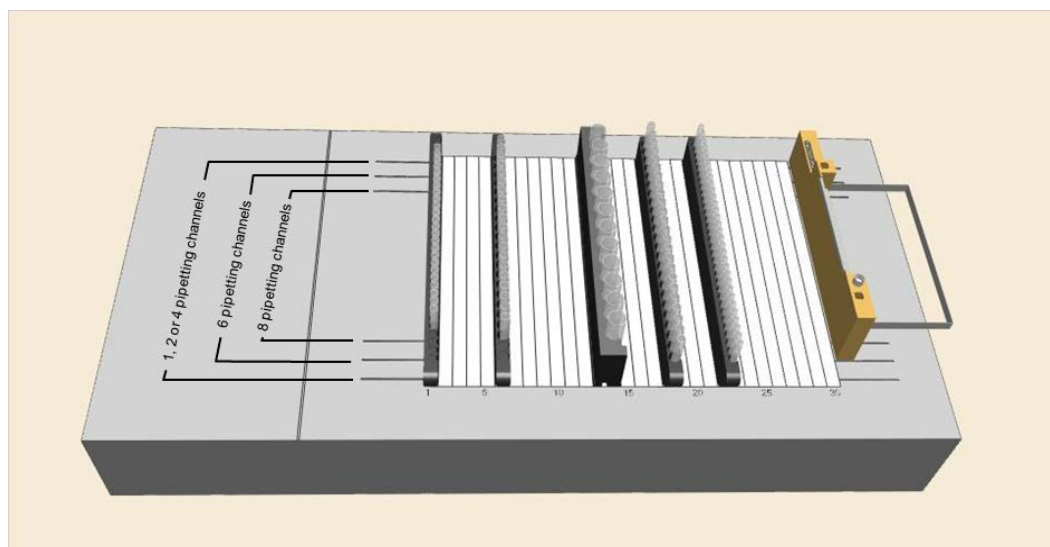

To guarantee random access to sample tube carriers, only the inner tube positions should be used.

**NOTE**

If pipetting positions outside the access space of the instrument are used, the system reports an error. However, a strictly batch-type process can eliminate these problems.

2.4.3 CO-RE 96 Probe Head

The CO-RE 96 Probe Head is a high-throughput pipettor built with the CO-RE technology as an ML STAR pipetting channel. The CO-RE technology guarantees fast and accurate pick-up and release of disposable tips.



cLLD (capacitive Liquid Level Detection) is available on the two special channels A1 and H12.

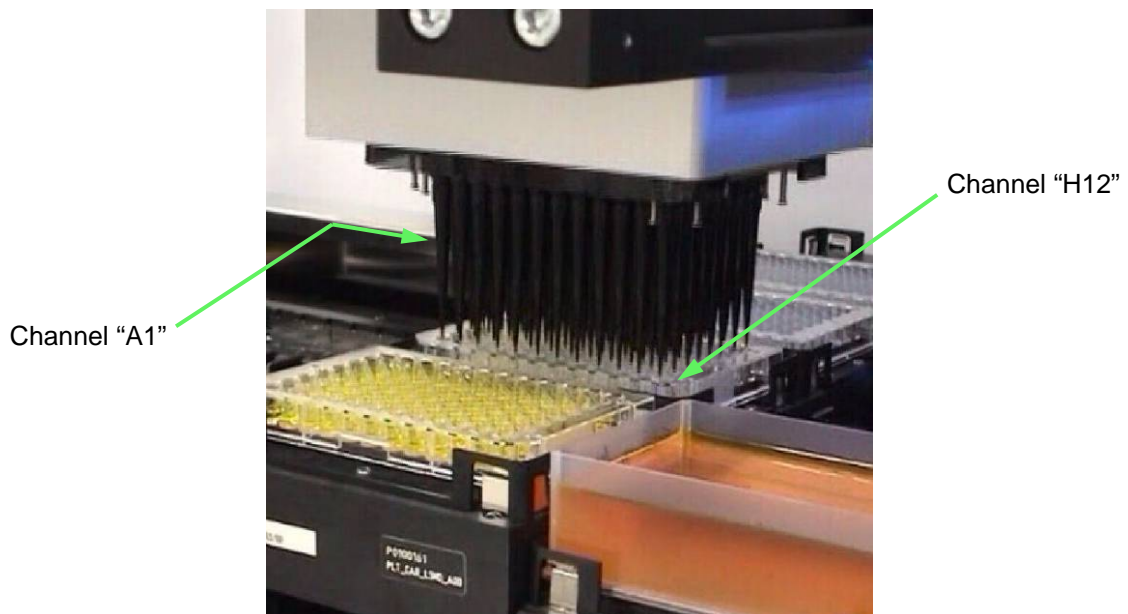

View from the Right to Left Side of the Instrument

The CO-RE 96 Probe Head is available with 96x 1000µl-pipetting channels. The 96 pipetting channels always work simultaneously with the same volume.





















The CO-RE 96 Probe Head supports pipetting with low-volume (10µl), intermediate volume (50µl), standard (300µl), high volume (1000µl), piercing and slim disposable tips. The following table gives an overview of disposable tips which can be used with the CO-RE 96 Probe Head. Other combinations may be possible, but require special attention.



NOTE

If a type of tip is not shown, it cannot be used for that purpose.

See [Section 8.2 Ordering Information](#) for a complete listing.

CO-RE 96 Probe Head / CO-RE 96 Probe Head TADM	Tips for Working Volume and Purpose					
	10µl CO-RE Tip	50µl CO-RE Tip	300µl CO-RE Tip	1000µl CO-RE Tip	250µl Robotic Piercing Tip	300µl Slim Tip
 96-Well						
 96-Well Archive						
 384-Well						
 384-Well Archive						

The use of a tip support makes picking up one or more columns, rows, a single quadrant or even a single tip feasible from a Nested Tip Rack (NTR) with the CO-RE 96 Probe Head.

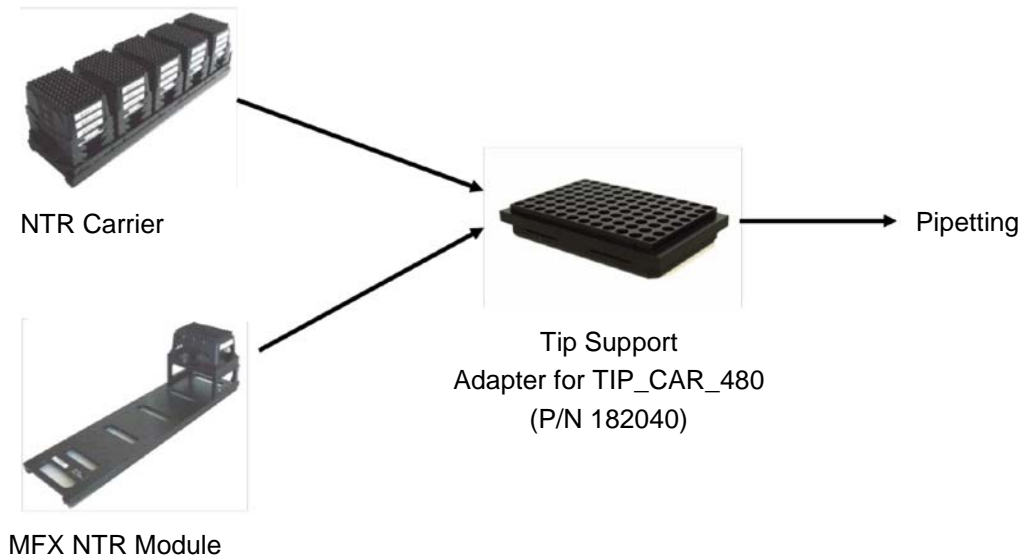

NOTE

For shifted tip pickup, make sure to use a tip support (P/N 182040) as an intermediate storage position for tips. It allows picking up of a single tip/row/column using the CO-RE 96 Probe Head.

The following table gives an overview of carriers and modules which can be used with the CO-RE 96 Probe Head. Other combinations may be possible, but require special attention.



NOTE

If a type of carrier or module is not shown, it cannot be used for that purpose.

See [Section 8.2 Ordering Information](#) for a complete listing.

CO-RE 96 Probe Head / CO-RE 96 Probe Head TADM	Carriers and Modules			
 <p>96-Well</p>	 <p>Plate Carrier for 96/384 Well Plates</p> <p>or</p>  <p>Deep Well Plates</p>	 <p>MFX DWP Nested</p> <p>or</p>  <p>MFX MTP Nested</p>	 <p>Plate Carrier for 1536-Well Plates</p>	 <p>Multiflex MTP Module</p> <p>or</p>  <p>Multiflex DWP Module</p>
 <p>96-Well Archive</p>	 <p>Plate Carrier for Deep Well Plates</p>	 <p>MFX MTP Nested</p>		 <p>Multiflex DWP Module</p>
 <p>384-Well</p>		 <p>MFX DWP Nested</p> <p>or</p>  <p>MFX MTP Nested</p>	 <p>Plate Carrier for 1536-Well Plates</p>	
 <p>384-Well Archive</p>		 <p>MFX MTP Nested</p>		

2.4.4 CO-RE 96 Probe Head TADM

Hamilton's proprietary TADM feature is available with the CO-RE 96 Probe Head TADM. All other features of this head are identical to those of the CO-RE 96 Probe Head. The CO-RE 96 Probe Head TADM is compatible with MPH ready ML STAR instruments and runs with VENUS TADM feature as well as with VENUS four.

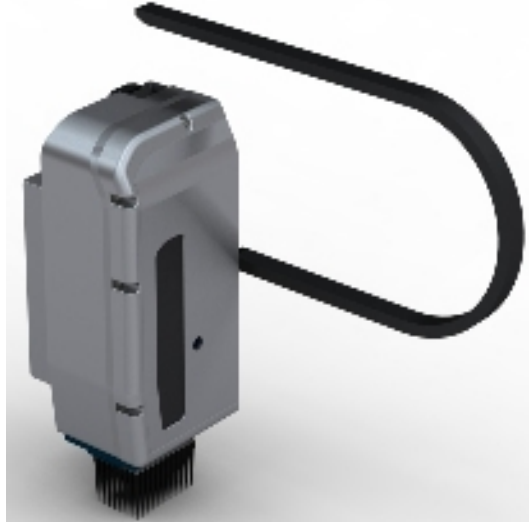

The CO-RE 96 Probe Head TADM supports pipetting with low-volume (10 μ l), intermediate volume (50 μ l), standard (300 μ l), high volume (1000 μ l), piercing (limited) and slim disposable tips. The CO-RE 96 Probe Head TADM could be used with piercing tips but does not work in all labware, thus makes pipetting with piercing limited.

The CO-RE 96 Probe Head TADM does not have enough force in the z-drive to pierce a 96 rack format occupied by tubes with caps. It is only possible to pierce a 96-well microplate with a thin aluminum foil, therefore piercing tips are used to pierce a 96-well microplate with the aluminum foil or tubes with caps.

Patent Numbers: EP2006022B1 (AT; CH; DE; ES; FR; GB; IE; IT; NL; NO; SE) JP4855496B US8245586B2
 EP2006020B1 (AT; CH; DE; ES; FR; GB; IT)
 EP2123359B1 (GB, AT, IT, FR, ES, CH, DE, FR, SE)

2.4.5 CO-RE 384 Probe Head

The CO-RE 384 Probe Head is a parallel pipettor. It uses the CO-RE technology as in the individual pipetting channels and the CO-RE 96 Probe Head, offering accurate and gentle tip pickup. The positioning accuracy allows pipetting into 96, 384 and 1536 well microplates. The 384 pipetting channels always work simultaneously with the same volume. The pipetting range is between 0.1µl and 50µl.



NOTE

Special 50µl tips are designed for pipetting with the CO-RE 384 Probe Head.



cLLD (capacitive Liquid Level Detection) is available on two special channels (A5 and P24).

The following table gives an overview of disposable tips which can be used with the CO-RE 384 Probe Head. Other combinations may be possible, but require special attention.



NOTE

If a type of tip is not shown, it cannot be used for that purpose.

See [Section 8.2 Ordering Information](#) for a complete listing.

CO-RE 384 Probe Head	Tips for Working Volume	
Plate Type	50µl Tip	300µl Tip
 <p>96-well</p>	 <p>384 Probe Head CO-RE Tips 50µl</p>	 <p>Rocket Tip</p>
 <p>96-Well Archive</p>	 <p>384 Probe Head CO-RE Tips 50µl</p>	 <p>Rocket Tip</p>
 <p>384-Well</p>	 <p>384 Probe Head CO-RE Tips 50µl</p>	
 <p>384-Well Archive</p>	 <p>384 Probe Head CO-RE Tips 50µl</p>	
 <p>1536-Well</p>	 <p>384 Probe Head CO-RE Tips 50µl</p>	

The use of a tip support makes picking up one or more columns, rows, a single quadrant or even a single tip feasible from a Nested Tip Rack (NTR) with the CO-RE 384 Probe Head.

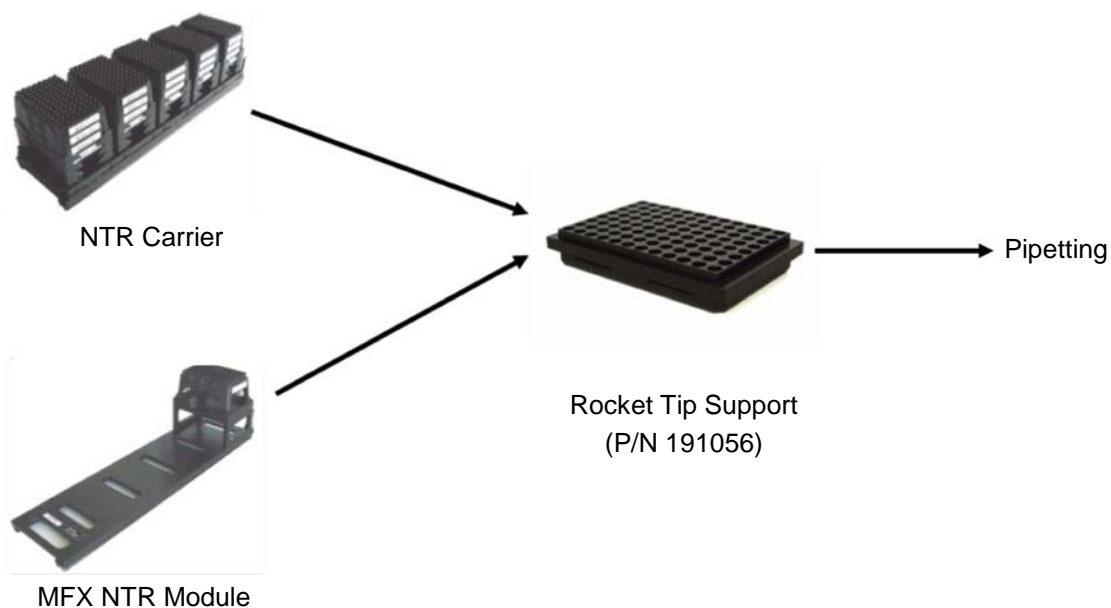

NOTE

For shifted tip pickup, make sure to use a CO-RE 384 Tip Support (P/N 191055) or Rocket Tip Support (P/N 191056) as an intermediate storage position for tips. It allows picking up of a single tip/row/column using the CO-RE 384 Probe Head

The use of special Nested Tip Racks (NTRs) equipped with 96 tips per rack (P/N 235993, P/N 235447, P/N 235695 sterile, P/N 235825 sterile; 96 of the 384 positions filled with tips) converts the CO-RE 384 Probe Head into a 96 pipetting channel head with a volume range of 50µl.

The use of Hamilton's Rocket Tips (P/N 235974) converts the CO-RE 384 Probe Head into a 96 pipetting channel head with a volume range of up to 300µl. The use of a tip support makes pickup of one or more columns, rows, a single quadrant or even a single Rocket Tip feasible from a Nested Tip Rack (NTR) with the CO-RE 384 Probe Head.

The following table gives an overview of carriers and modules which can be used with the CO-RE 384 Probe Head. Other combinations may be possible, but require special attention.



NOTE

If a type of carrier or module is not shown, it cannot be used for that purpose. See [Section 8.2 Ordering Information](#) for a complete listing.

CO-RE 384 Probe Head	Carriers and Modules			
 <p>96-Well</p>	 <p>Plate Carrier for 96/384 Well Plates</p> <p>or</p>  <p>Deep Well Plates</p>	 <p>MFX DWP Nested</p> <p>or</p>  <p>MFX MTP Nested</p>	 <p>Plate Carrier for 1536-Well Plates</p>	 <p>Multiflex MTP Module</p> <p>or</p>  <p>Multiflex DWP Module</p>
 <p>96-Well Archive</p>	 <p>Plate Carrier for Deep Well Plates</p>	 <p>MFX MTP Nested</p>		 <p>Multiflex DWP Module</p>
 <p>384-Well</p>		 <p>MFX DWP Nested</p> <p>or</p>  <p>MFX MTP Nested</p>	 <p>Plate Carrier for 1536-Well Plates</p>	
 <p>384-Well Archive</p>		 <p>MFX MTP Nested</p>		
 <p>1536-Well</p>		 <p>MFX DWP Nested</p> <p>or</p>  <p>MFX MTP Nested</p>	 <p>Plate Carrier for 1536-Well Plates</p>	

2.4.6 Pin Tools

Pin Tools from a 3rd party provider can be used with the ML STAR instruments. A Pin Tool is an array of metal pins for the transfer of small (nanoliter) amounts of liquids into high density formats. Hamilton offers an adapter and accessories for Pin Tools from V&P Scientific, Inc. (www.vp-scientific.com) to be used with the CO-RE 96 Probe Head TADM or the CO-RE 384 Probe Head.

The Pin Tool Adapter Plate (ADAPTER PLATE PIN TOOL 96/384 P/N 188154APE) couples the Pin Tool 96/384 with the CO-RE 96 Probe Head or CO-RE 384-Probe Head. It will be produced according to the available type of Pin Tool and depends on the head type (CO-RE 96 or 384 Probe Head).

Service Carriers (without Pin Tool) exist for Pin Tool 96 (PINTOOL 96 SERVICE CARRIER, P/N 188145APE) and for pin tool 384 (PINTOOL 384 SERVICE CARRIER, P/N 188146APE) on a Multiflex Base:

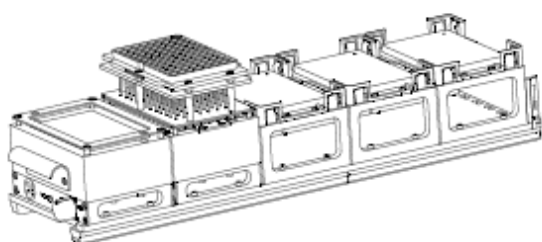

Service Carrier (without Pin Tool or Pin Tool Adapter) on Multiflex Base including:

- 1x Multiflex Base Plate
- 1x parking positions for Pin Tool 96
- 1x Heated Air Drying Station
- 3x Deep Well Plate positions for Troughs with Wash Solutions

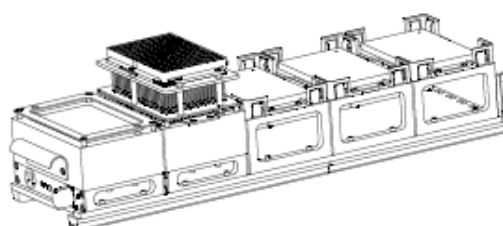

Service Carrier (without Pin Tool or Pin Tool Adapter) on Multiflex Base including:

- 1x Multiflex Base Plate
- 1x parking positions for Pin Tool 384
- 1x Heated Air Drying Station
- 3x Deep Well Plate positions for Troughs with Wash Solutions

The service carriers come with labware definitions for the Pin Tool.



NOTE

Using a Pin Tool requires the pin tool itself (order from V&P Scientific, Inc.), the Pin Tool 96/384 Adapter Plate (which will be produced at Hamilton according to the specific Pin Tool), and the Pin Tool Service Carrier.

2.4.7 iSWAP

The iSWAP (internal Swivel Arm Plate Handler) is a robotic arm that transports microplates, lids of microplates, archive plates, filter plates to and from positions on the instrument deck. Plates can be placed in landscape or portrait orientation or rotated. It is possible to pick up labware from and place it to labware any position inside or even outside of the deck. Typical handling tasks like loading/unloading of plates outside the instrument becomes very simple with the iSWAP. The iSWAP can also stack plates or tips with specially provided carriers.

Among the special features of the iSWAP is a sensor which signals to the robot when a labware object is gripped. The newest generation of the iSWAP monitors the presence of an object. Like the ML STAR pipetting channels, the iSWAP has a “traverse height” of 145mm above the deck (245mm above the origin).

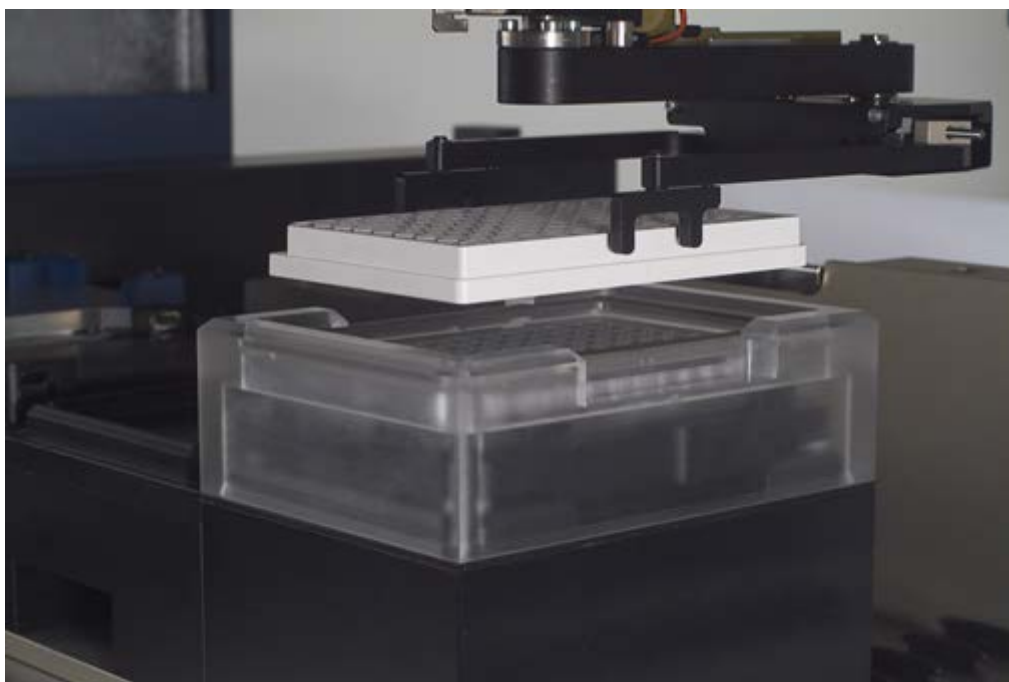

iSWAP Robotic Hand at work Transporting Microplates to the CVS

The iSWAP is mounted on the pipetting arm. It does not affect the movement of the pipetting tools.

2.4.8 Tube Gripper

The Tube Gripper transports tubes to and from positions on the instrument deck. The tube-gripper tool is mounted to a separate channel. It can handle tubes with diameters from 8mm up to 20mm and up to a length of 120mm.

The tube-gripper is moved independently on the y-axis, as well as on the z-axis. The use of high-precision motors and electronics allows the tube-gripper to reach any position on the deck without the need of teaching.

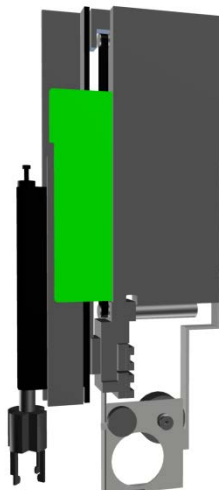

Tube Gripper Channel

Like ML STAR pipetting channels, the tube-gripper has a “traverse height” of 145mm above the deck (245mm above the origin) between the tube and the deck of the instrument. This means that when a tube is moved from one location on the deck to another, it automatically does so at that particular height. This is a safety precaution, so the transported tube will not collide with any items on the deck.

2.4.9 AutoLys Tube Channel

The AutoLys channel handles AutoLys tubes. It is mounted to a separate channel.



Autolys Channel

The AutoLys tube is an automation-friendly consumable designed for sample lysis and extraction. It is a 3-part assembly consisting of an outer tube with a 2D barcode, an inner tube with flow-thru filter and a threaded cap. The AutoLys tube facilitates processing and filtering of up to 500µl of lysate. The lysate is usually captured by centrifugation.



*AutoLys Tube
(right: spin position)*



*2D Barcode on the bottom of the
AutoLys Tube*



Four AutoLys Tool Channels



Four AutoLys Tool Channels holding AutoLys Tubes

The AutoLys Tool Channel is moved independently on the y-axis, as well as on the z-axis. The use of high-precision motors and electronics allows the AutoLys tool channel to reach any position on the deck without the need of teaching. It automates the entire process of AutoLys tube handling during a lysis procedure:

- De-capping the AutoLys tube, holding the cap and re-capping the tube
- Transfer the AutoLys tube to and from racks
- Lifting the inner tube and locking it in the “spin position”
- Removing and holding the inner tube post centrifugation
- Replacing the inner tube in the original outer tube

2.4.10 Tube-Twister Channel and Decapper Module

2.4.10.1 Tube-Twister Channel

The Tube-Twister Channel can grip and rotate or mix tubes, read their barcodes and transport the tubes to and from positions on the instrument deck. The Tube-Twister is mounted to a separate channel. It can handle tubes with diameters from 15mm up to 38mm and caps from 18mm up to 44mm. The maximum tube length including cap is 120mm.

The Tube-Twister Channel is moved independently on the y-axis, as well as on the z-axis. The use of high-precision motors and electronics allows the Tube-Twister Channel to reach any position on the deck without the need of teaching. The attached Tube-Twister Head is specific for the Tube-Twister Channel and includes two drives. One Twister Drive is able to grip tubes with its four fingers. The other Twister Drive rotates the Gripper Tool. This motion can be used to rotate the tube for barcode identification and for alignment, placing the tube in a carrier with the barcode in the correct position. A 1D barcode reader is attached to the Tube-Twister Channel. Barcode reading is executed after gripping the tube. The motion can also be used for mixing liquids inside the tube.



Four Tube Twister Channels holding tubes

Like ML STAR Pipetting Channels, the Tube-Twister has a “traverse height” of 145mm above the deck (245mm above the origin) between the tube and the deck of the instrument. This means that when a tube is moved from one location on the deck to another, it automatically does so at that particular height. This is a safety precaution, so the transported tube will not collide with any items on the deck.

In combination with the De/Re-Capper Module, the Tube-Twister can also be used for decapping and recapping of tubes.



ATTENTION

Do not overfill the tubes: fill approximately 15mm below the top of the tube to avoid spillage.

When mixing liquid, the mixing speed has to be adjusted to the type of tube and the volume within the tube to prevent cross-contamination due to spillage.

Do not mix liquid (spinning), while tubes are open. Ensure that the tubes are completely closed before processing.

2.4.10.2 Decapper Module

In combination with the Tube-Twister, the Decapper Module allows opening and closing tubes with screw-top caps. A decapper module consists of up to four decapper positions, where each position consists of two rings. The upper ring clamps and turns the cap, the lower ring clamps the tube. For reliability and increased process control, the de/re-capper module is equipped with independent upper ring drive and lower ring drive.

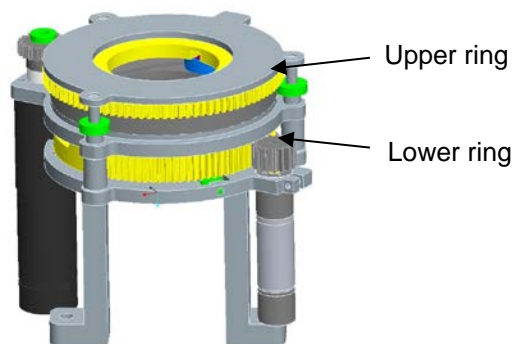

De/Re-Capper Module



ATTENTION

Glass tubes cannot be opened or closed with the Decapper Module.

Tubes with equal or smaller diameter caps cannot be opened or closed with the Decapper Module.

For de-capping, a capped tube is presented to the Decapper Module using the Tube Twister Channel. The lower ring of the Decapper is closed in order to hold the tube. The upper ring is closed to hold the cap and disengage the cap from the tube. The Tube Twister Channel unscrews the cap and discards it into the waste or holds it for further re-capping. The lower ring of the module releases the tube. At this stage, the pipetting channels have access to the liquid in the tube. Alternatively, the tube can be transported to a different location by the Tube Twister Channel.

For re-capping, an uncapped tube is presented to the Decapper using the Tube Twister Channel. The lower ring of the Decapper is closed in order to hold the tube. The Tube Twister Channel gets a cap from a cap supply and screws the cap to the tube with minimal force. The cap is then finally locked using the upper ring of the Decapper. The capped tube is released and can be transported by the Tube Twister Channel.

Up to two Decapper Modules can be mounted on the deck of the ML STAR (see below).



*Eight Decapper Modules mounted on the Deck
Four Tube-Twister Channels (above)*

The Decapper Module is available in two different versions

- Decapper Module Small
- Decapper Module Large

(See section “[Technical Specification](#)” for supported tubes)

2.4.11 Imaging Channel

The purpose of the imaging channel is to capture the digital image from any object placed on the instrument deck. A high-resolution CCD-Camera is fixed on a separate channel and allows acquiring images from a target which is as big as the SBS format. The images are sent to the image analyses software for further investigation.

A typical application is the image analysis of bacteria colonies. In the proprietary easyPick software, the user defines parameters and determines the weighting for the typical criteria to identify colonies: coordinates, size, shape (circularity), color, proximity to the next colony, distance to the margin, etc.

Reliable automation requires proper quality of the analyzed images. Appropriate lighting of the object of interest is fundamental. In case of image analyses of bacteria colonies a back-light table is used in the system. For other applications different lighting options can be applied.

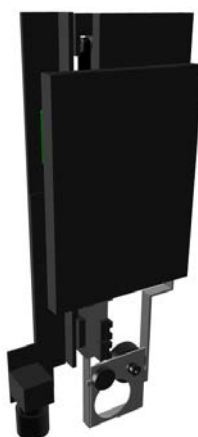

2.4.12 Imaging Applications

- Camera on a separate Channel
- Light Table Carrier
- Image Analysis Software



2.4.12.1 easyBlood

Camera Channel:

- Required for the fraction detection
- Fixed focal length
- Takes picture of 4 tubes at once



Mirror Carrier:

- Presentation of Tubes to the Camera

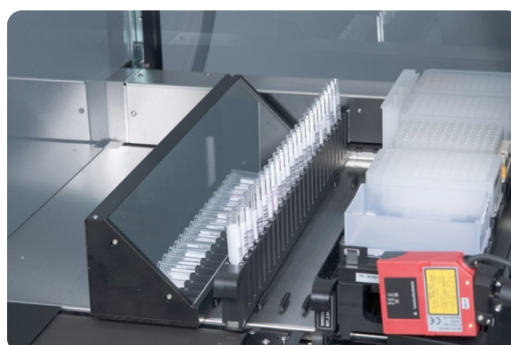

2.4.12.2 easyCode Carrier

easyCode Carrier:

- Code Identification achieved with integrated Hamilton 2D Code scanner carrier
- Small Footprint: 6T (7T) Carrier
- Reading time: 1 sec
- Decoding time: 96 Tubes -> 3 sec
- For all types of racks with 12, 24, 48, 96, 384 tubes
- Reads all types of codes:
- FluidX, Matrix, Micronic, NUNC, Abgene, REMP/Nexus, Hamilton, Greiner, Axygen, Corning, all Datamatrix ECC 200
- "No tube"- recognition, differentiation between missing tubes and unreadable codes

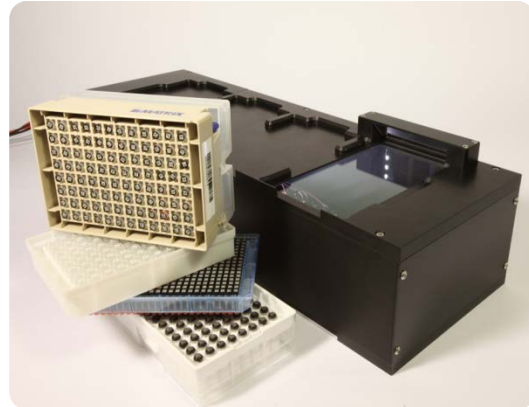

2.4.13 Multiflex Media Line

The Multiflex Media Line is used to fill a SBS Reagent Container on the Deck of a STAR Instrument, from which a MPH or single pipetting channels can aspirate medium. In comparison to the Multiflex Liquid Dispenser, which has a similar function, the Media Line is more sterile. Also, the temperature of the medium is controlled by the Pre-Heating Module. All tubing including Dispense Arm and Drain can be autoclaved and can be replaced easily by the customer. Typically, one medium is used to fill the Reagent Container, whereas a disinfectant and water is used for cleaning and rinsing.

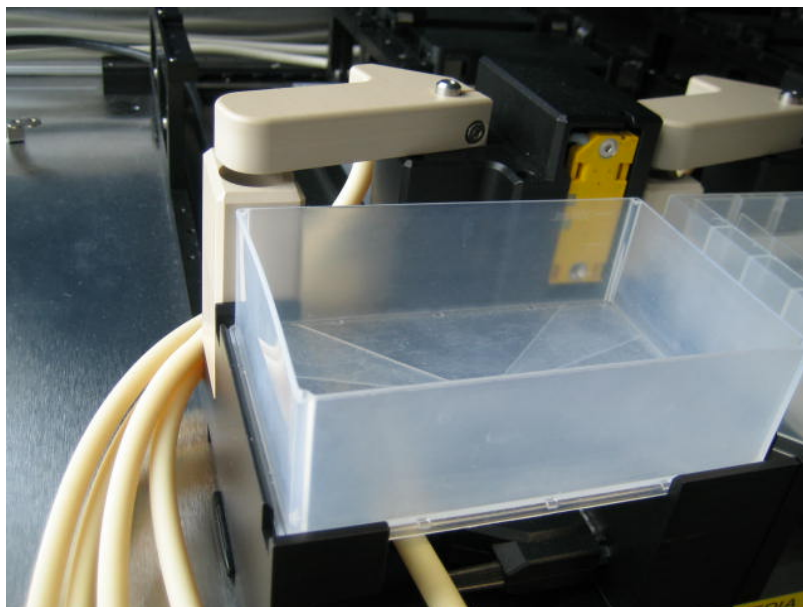

The Media Line is mounted on a special Multiflex Base Plate with an overflow basin. The Liquid Level of the Reagent Trough is controlled by a Capacitive Liquid Level Sensor. One Peristaltic Pump Unit fills and maintains the level in the SBS Reagent Container, the other Peristaltic Pump Unit transports the liquids from the drain into a Waste Container (provided by the customer). The Dispense Arm with a spout has two defined positions: one over the Reagent Container for filling, the other over the drain for cleaning and rinsing the tubing. Up to 3 Media Lines can be mounted onto one Base Plate.

Optionally, a controlled heater plate can be mounted underneath the Media Trough.

For each Media Line, there is a safety overflow stop mounted in the overflow basin. Should the Liquid Level Sensor (due to a fault) fail to detect that the Reagent Container is full, the fill pump will be stopped automatically as soon as the safety overflow stop detects any fluid in the overflow basin.

2.4.14 CO-RE Gripper

The CO-RE gripper is a plate handling tool picked up by two pipetting channels during a run. This tool is only available if the system has at least two individual pipetting channels.

The CO-RE gripper transports microplates, lids for microplates, archive plates, filter plates, etc. to and from positions on the instrument deck. Plates can be gripped in landscape or portrait format within the working area. Rotation of plates is not an option.

The traverse height of the pipetting channels with the gripping jaws is the same as with tips: 145mm above the deck. Given that there is no sensor working; one must ensure that CO-RE gripper does not grip plates too tightly causing them to rattle. On the other hand, a loose CO-RE gripper can result in a step loss.



*CO-RE Grippers mounted on waste block:
1000µl-Pipetting Channels (inner positions) and
5ml-Pipetting Channels (outer positions)*

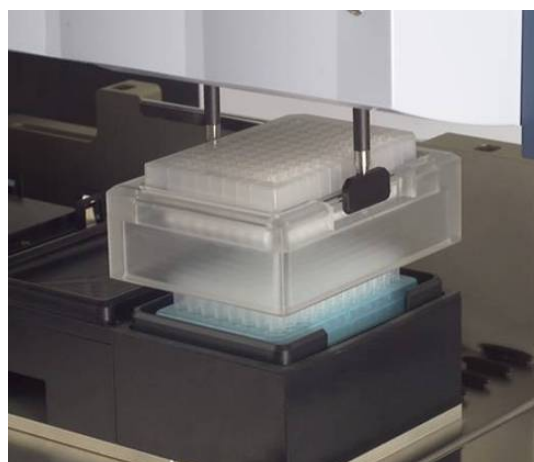

CO-RE Gripper on 1000µl-Pipetting Channels

The CO-RE grippers are available for waste block- and for plate carrier mount. Plate carrier mount requires one freely selectable SBS position on deck, whereas waste mount does not consume space on deck.



NOTE

When using plate stacks or filter plate systems with an elution plate on the CVS, the stacked plates and elution plates are only accessible by the CO-RE gripper, NOT with the iSWAP.

2.4.15 FlipTube Tool

Hamilton FlipTubes are 1.5ml reagent tubes with a lid attached which can close the tube tightly for convenient and reliable preparation, centrifugation and storage of small volume samples. The FlipTube tool is used for opening and closing Hamilton FlipTubes. It is picked up by a 1000 μ l-pipetting channel during a run. Up to four FlipTube tools can be used in parallel when picked up by four 1000 μ l-pipetting channels, if available. The traverse height of a channel with the FlipTube tool is the same as with tips: 145mm above the deck.

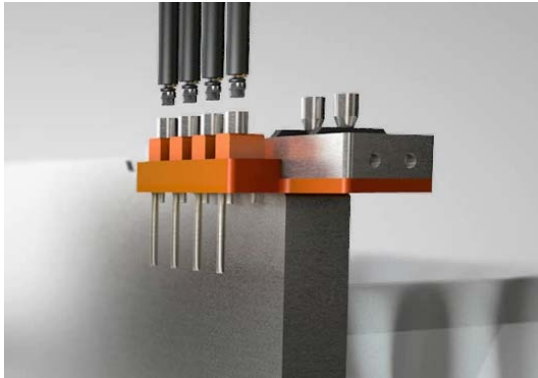

A Set of 4 FlipTube Tools (consisting of four fingers) within the holder



Hamilton FlipTube A (P/N 235454)



NOTE

The FlipTube Tool can be used for Hamilton FlipTubes only, not for other locked tubes.

Park positions (holders) for FlipTube Tools are available for a Multiflex Carrier or for the waste block. The park position on the waste block has the advantage that it does not consume a plate position.

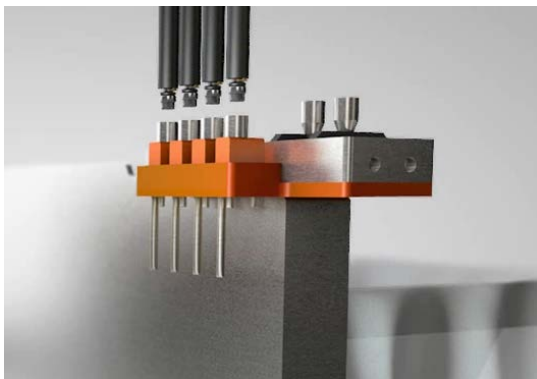

*FlipTube Tool Park Position on the Waste Block.
The long rod faces to the left hand side on the deck.*

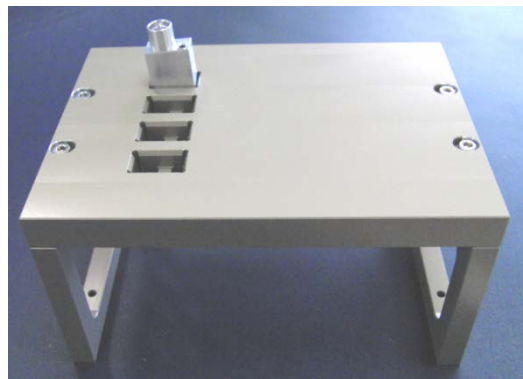

*FlipTube Tool Park Positions for a Multiflex Carrier in their correct orientation on the deck,
FlipTube Tool positioned on the left hand side, long rods facing left.*



NOTE

FlipTube Tools have to be aligned on the deck such that the long rod is on the left hand side of the park position.

FlipTubes must be fixed tightly in a special carrier or adapter for opening and closing by a FlipTube tool. This is achieved by a specific sample carrier, an adapter for a Multiflex Module or an adapter for the Hamilton Heater Shaker.



Sample Carrier for 32 FlipTubes SMP_CAR_32FT (P/N 809030)



NOTE

The Multiflex adapter for FlipTubes and the HHS adapter for FlipTubes have to be aligned on the deck such that the lid of the tube faces to the left hand side.



NOTE

The Multiflex adapter for FlipTubes and the HHS adapter for FlipTubes have to be aligned on the deck such that the lid of the tube faces to the left hand side.



*Multiflex Adapter for FlipTubes (P/N 814275).
Mounted such that the lids of the tubes face left.*



HHS 3 (P/N 199085) equipped with a built-in adapter for a FlipTube Rack.

**ATTENTION**

For best performance:

- *Use a demo method for optimal process safety*
- *Tip has to dispense inside the tube*

**ATTENTION**

Use carefully the spring elements of the FlipTube Carrier

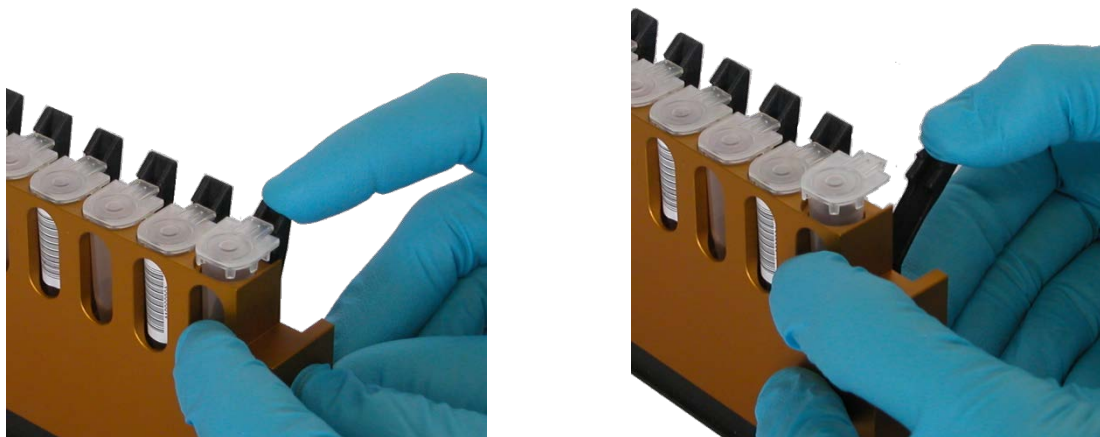
**NOTE**

FlipTubes are normally mounted on the waste block or in the SBS position; however, when the waste block is occupied by the CO-RE gripper, either the SBS position or the FlipTube tool will be used instead. For more information about FlipTubes, please refer to the FlipTube Manual. There is a spring on the carrier or adapter which can be adjusted when necessary.

2.4.16 CO-RE Lid Tool

The CO-RE lid Tool (CLT) is a suction cup device for picking up and transporting lightweight lids of petri dishes, plates, troughs and reservoirs. It can be picked up by a 1000µl-pipetting channel. The plunger drive generates a negative pressure (vacuum) on the surface of flat clean labware objects so that they can be lifted. When not in use, the CO-RE Lid Tool is parked on the waste block in one of the teaching/maintenance needle positions.

The CO-RE Lid Tool can also be parked on a SMP-CAR-32 (P/N 173410).

- Labware: Petri-dish lids, microplate lids, trough and reservoir covers can be transported
- Park position: on the waste block in one of the teaching/maintenance needle positions
- Transport device: 1000ul-pipetting channel
- Move-Control: Move-control by a *.hsl library

Labware pickup and eject positions / tool park position / number of 1000ul-pipetting channels has to be defined.

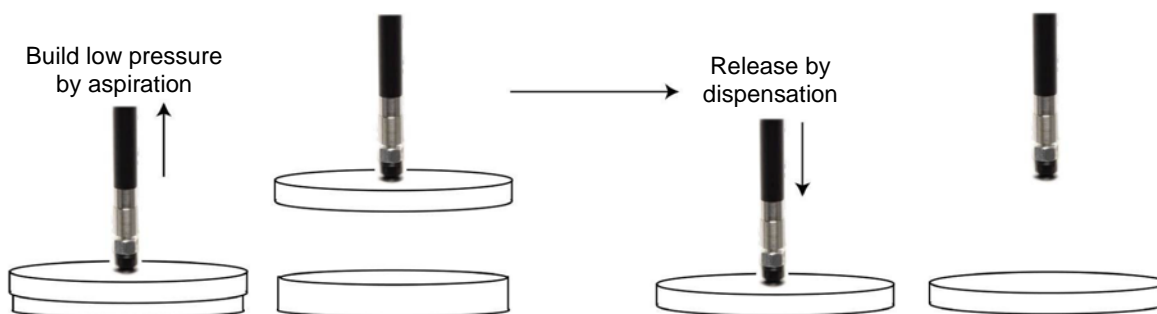

Mode of operation of the CO-RE Lid Tool

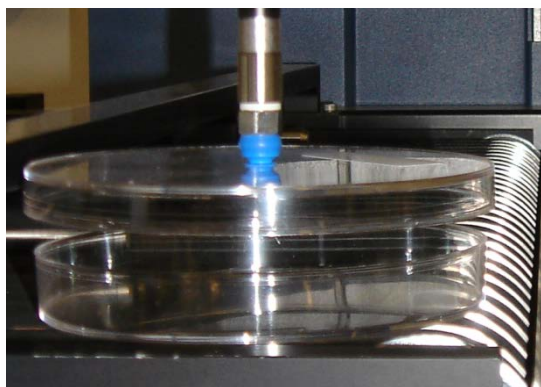

CO-RE Lid Tool picking up the Lid of a Petri Dish



CO-RE Lid Tool on its Park Position on the Waste Station

For operation of the CO-RE lid tool, a special library is required. The labware pick-up and eject positions, the tool park position and the channel to be used have to be defined.



NOTE

Please consult the local Hamilton representative for the specific library to use the CO-RE lid tool.

2.4.17 Autoload Option

The Autoload option of the ML STAR configuration must be specified by the customer at the time the instrument is purchased. To retrofit at a later time cannot be done.

The Autoload drive is a device enabling automatic loading of carriers onto the ML STAR instrument deck:

- Moves in the x-direction
- Shunts carriers on and off the deck
- Reads barcodes of carriers, tubes, and microplates

There is a presence sensor that identifies if tubes are present on a sample carrier.

Carrier identification by barcodes, and reading of barcodes on plates and tubes, is only possible in combination with the Autoload option.

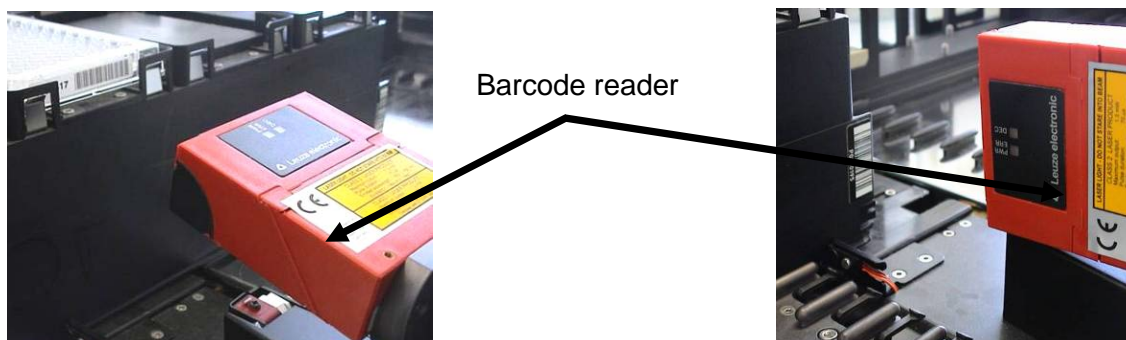

The Autoload option including the Barcode Reader, which is shown reading horizontally for microplates and vertically for carriers and tubes

The following barcode symbologies can be read by the Autoload Option:

- ISBT Standard
- Code 128 (Subset B and C)
- Code 39
- Codabar
- Code 2 of 5 interleaved
- UPC A/E
- JAN/EAN 8

Barcodes must be black bars on a white background. Hamilton recommends using the barcode type Code 128 (Subset B and C).



NOTE

In addition, barcodes must have a minimum readability (i.e., good contrast, size, correct orientation and distance between bars) to be fully functional.

Ensure the correct barcode orientation for tubes and plates (see specifications).

For details of barcodes, see the specifications given in [Section 7.29.3 Barcode Specifications](#).

2.5 Accessories

Accessories are defined as additional automation components. They provide a high degree of adaptability and permit customizing for multiple applications. These components can be ordered later by the customer and installed by Hamilton-authorized personnel.



NOTE

An accessory may require a library, labware definitions, etc. for use with the VENUS software. Please consult a local Hamilton representative.



NOTE

The availability of accessories is subject to change. Please consult a local Hamilton representative or visit www.hamiltonrobotics.com.

2.5.1 Carriers

Labware such as plates or tubes are placed on special carriers that are loaded onto the ML STAR instrument deck. Hamilton provides a wide range of standard carriers for microplates, tubes, tips, etc. All standard carriers can be loaded to the deck manually or by the Autoload option.

The naming of carriers follows a systematic nomenclature “**X_CAR_Y_Ann**” where

- X** represents the type of labware placed on the carriers, e.g.
 - TIP** (= tips)
 - PLT** (=plates)
 - SMP** (=samples)
 - RGT** (=reagent)
- CAR** carrier
- Y** describes the labware details, e.g.
 - L**: landscape orientation
 - P**: portrait orientation
 - Number**: number of items placed on the carrier (plates or tips)
 - MD**: medium density (96- or 384-well micro-plates)
 - HD**: high density micro-plates (1536)
 - AC**: 96-well archive plates
- Ann** identifies the part number revision (e.g. A00)
 - A**: variant
 - nn**: revision

Example: PLT_CAR_L5MD_A00 is a plate carrier for 5 medium density (96- or 384-well) micro-plates in landscape orientation.

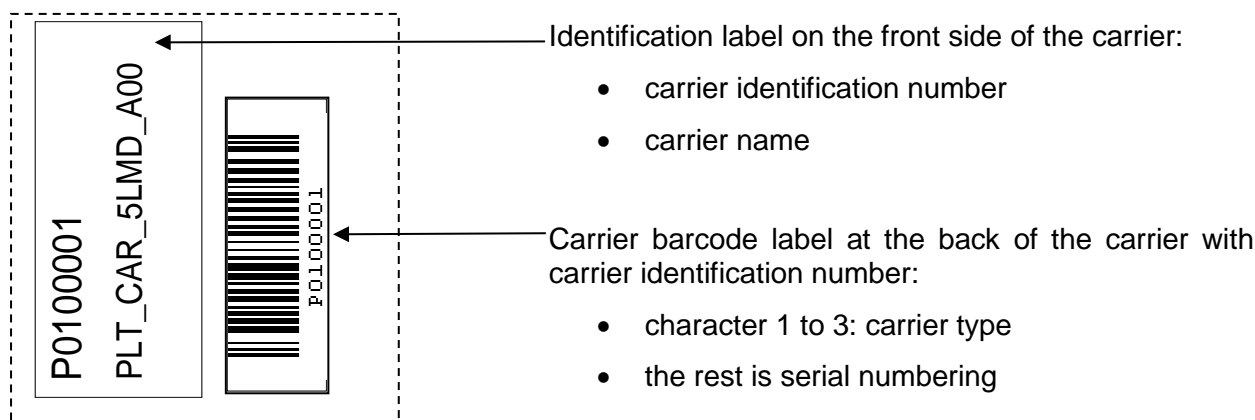

Carrier barcode labels



A carrier must always be identified in the VENUS software (e.g. in deck layouts and methods) by the unique description with which it is tagged.

2.5.2 Multiflex Carrier

The Multiflex Carrier consists of a multiple-use carrier base offering space for up to five modules. Several modules can be chosen, such as: tip rack module, microplate module, plate stacker module, module for heating or cooling labware, reagent trough module, tube or cup module, etc. The list of available modules can be found in [Section 8.2 Ordering Information](#).

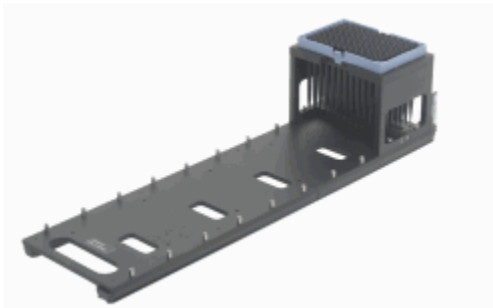

Multiflex Tip Module on the Multiflex Carrier

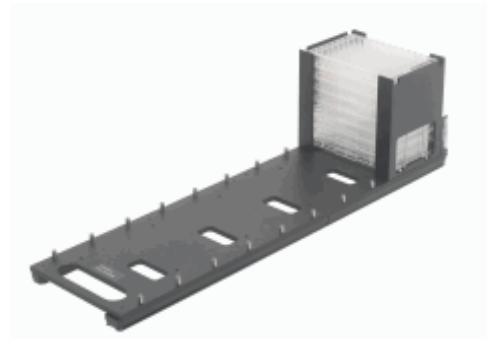

Multiflex Stacker Module (landscape) on the Multiflex Carrier



NOTE

For configuring Multiflex Carriers, a Multiflex Carrier Assistant Software Tool is required. Please consult a local Hamilton representative.



NOTE

The availability of accessories is subject to change. Please consult a local Hamilton representative for an up-to-date list, or consult www.hamiltonrobotics.com.

The modular design of the Multiflex Carrier allows space optimizing and customizing the instrument. This carrier will occupy 6 tracks of the instrument deck.

2.5.3 Hamilton SBS Centrifuge

The Hamilton SBS Centrifuge is a dedicated device for automated processing of SBS plate formats such as DWP, standard microplates, AutoLys racks, etc. The Hamilton SBS Centrifuge is integrated into the ML STAR Instrument, and not used as a stand-alone device.

The integration of the Hamilton SBS Centrifuge has to be quoted with a Level I Integration (188842APE), Level II Integration (188544APE), or Level III Integration (188454APE), depending on the customer's requirements.

The CO-RE gripper (184089) is required for transport of labware into the centrifuge.

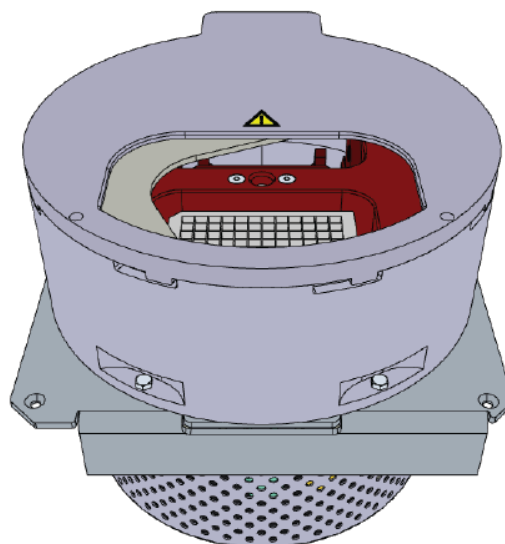

The Hamilton SBS Centrifuge library installer is available in the Resource Center.

Integration on the ML STARlet

- Integration on the right side (waste side) of the instrument, similar to the MassSTAR instrument
- Requires Thin Arm: Arm MPH/iSWAP or iSWAP Arm
- Not compatible with the Modular Arm or Modular Arm MPH



Since the centrifuge takes the place of the waste in this configuration, the waste has to be modified, requiring a dedicated virtual Deck Layout where the waste position is shifted. The deck layout installer is available from the Resource Center.

Integration on the ML STAR, ML STARPlus

- Integration on the deck is possible, similar to the Autolys configuration.



2.5.4 HAMILTON Heater Shaker

The HAMILTON Heater Shaker (HHS) is designed to heat and shake microplates in SBS format. Loading and unloading as well as the independent heating or shaking function of the HHS is fully controlled by the VENUS software.

Before shaking, the plates are locked and positioned in the center of the HHS. When the shaking process has finished, the plates are unlocked and can be easily removed from the heater shaker, either using iSWAP or CO-RE Gripper (do not move/remove plates manually from the HHS).

The HHS adapters fitted to your plate type allow optimal heating of your samples. The maximum set temperature of the HHS is 105°C. To ensure reliable heating performance, two sensors permanently control the temperature which guarantees the abundance of the user-defined temperature range. In addition, a cut-off temperature will protect your samples from over-heating.



HHS with standard universal flat bottom adapter



ATTENTION

Only labware which complies with the HHS dimensions can be used in order to prevent any loss of plates and/or liquids.

When shaking labware, the velocity must be adjusted to the type of labware and the volume within the labware to prevent cross contamination due to spillages.

Flammable liquids must not be heated by the HHS as they might cause fire.

Make sure that the plate used with the HHS is heat resistant (maximum temperature 105°C).



NOTE

An efficient heating of the liquid is only achieved if the appropriate adapter for the labware is used. The heating time and the maximum temperature, which can be reached for the liquid inside the plate, is dependent on the amount of liquid, the size and weight of the used labware, the shape of the used adapter and the heating effectiveness between the plate and the adapter.

The maximum speed of the HHS depends on the eccentric tappet and the labware used. Shaking can be performed clockwise or counter-clockwise.

2.5.4.1 Up to 2 HHS

It is possible to integrate one or two HHS directly into an ML STAR instrument (via the TCC connector, see picture below). The power and communications run inside the same cable. Both HHS are fully controlled by the ML STAR software.

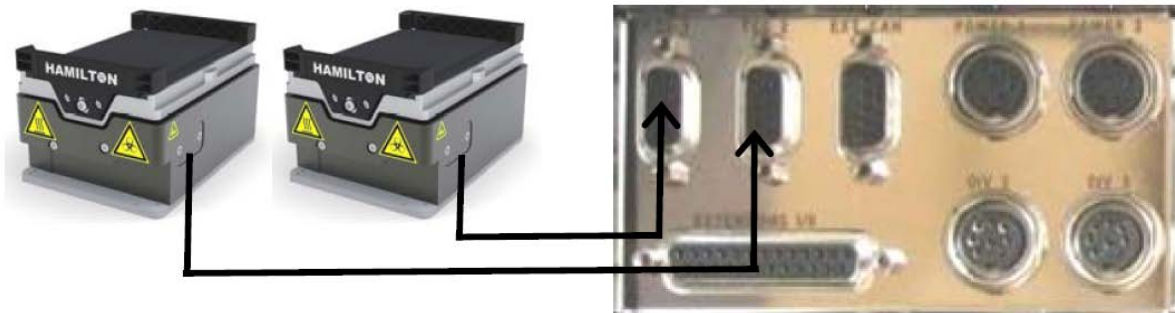

Two HHS connected to a ML STAR instrument



ATTENTION

Before connecting or disconnecting the HHS from or to a ML STAR instrument, make sure that the ML STAR is switched off. Only when the ML STAR is switched off is it safe to connect or disconnect the HHS. Not obeying this instruction may result in damage to the HHS.

Do not touch the HHS by hand during run time and shortly after finishing a run, as it might be hot. Wait until the HHS has cooled down to room temperature.



NOTE

The HHS is intended to be used in combination with an ML STAR instrument only!

Do not use the HHS as a stand-alone device.

**ATTENTION**

When working with toxic chemicals or samples, which will be used in particularly sensitive tests, take into account the evaporation that may occur while the HHS is running.

Be aware that heating of liquids will affect the pipetting process, as well as shaking the labware can influence the precision of pipetting.

2.5.4.2 Up to 8 HHS

If more than two HHS are required, the Heater Shaker Box (HSB) is needed. One HHS (HHS master) is connected to the USB port of the PC which serves as the master module. In addition to the master HHS, up to seven additional HHS (HHS slave 1...7) can be connected to the HSB. The HSB serves as a power supply and signal distributor for all the HHS slaves.

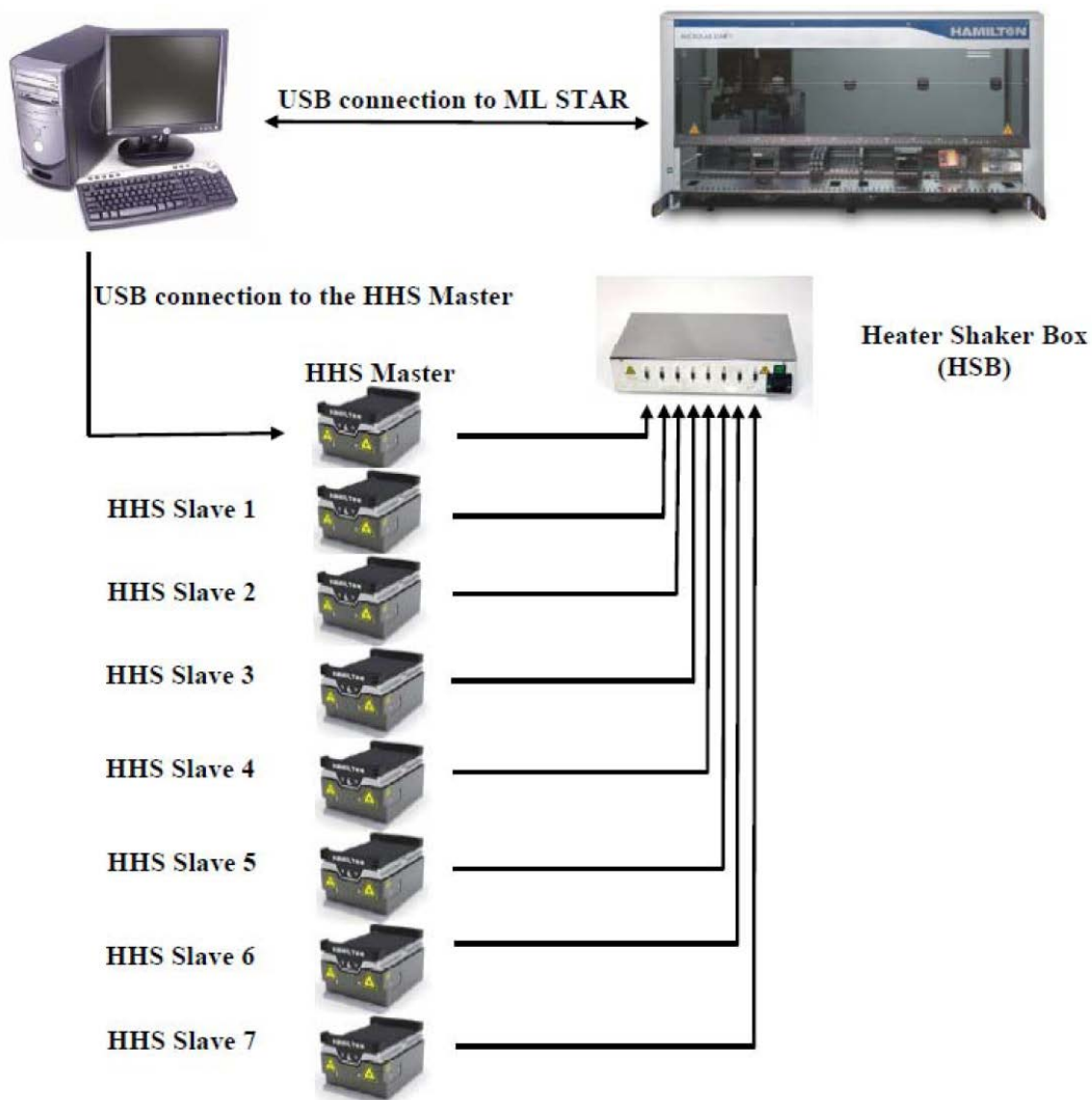

Up to eight HHS connect to the Heater Shaker Box (HSB) and the ML STAR PC



ATTENTION

When working with samples, which will be used in particularly sensitive tests, take into account the evaporation that may occur while the HHS is running. Be aware that heating of liquids will affect the pipetting process, as well as shaking the labware can influence the precision of pipetting.



ATTENTION

When shaking labware, the velocity has to be adjusted to the type of labware and the volume within the labware to prevent cross-contamination due to spillages.

2.5.4.3 Installation of the Hamilton Heater Shaker

Generally; the HHS will be installed by a Hamilton trained field service engineer.

Up to 4 HHS can be mounted onto one carrier base plate for heater shakers. A HHS for Deep Well (archive) Plates should be positioned directly onto the carrier base plate; the position of a HHS for standard plates can be elevated by using the HHS support block.

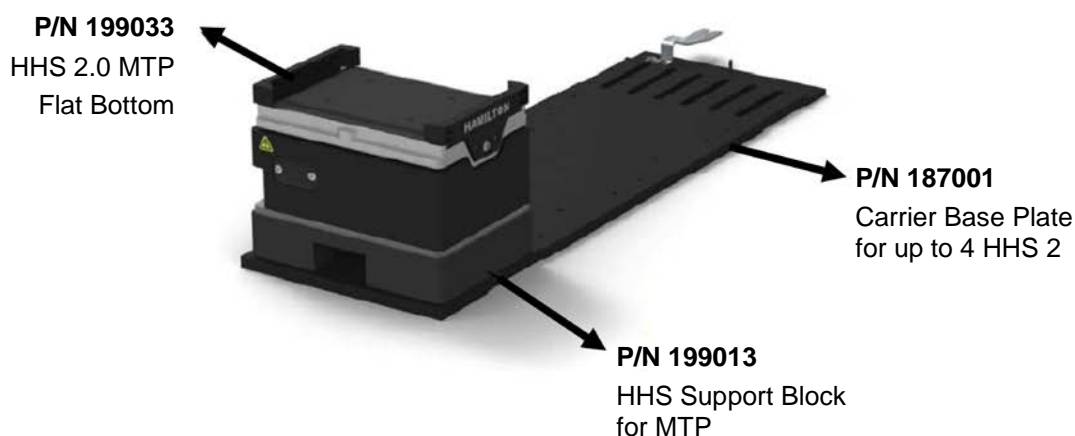

Ordering example for HHS with flat bottom



NOTE

*Carrier base plate and support block have to be ordered separately.
For Ordering information, see [Section 8.2 Ordering Information](#).*

Instead of microplate shakers, however, the shaker carrier base can be equipped with ordinary microplate modules. The list of available modules can be found in [Section 8.2 Ordering Information](#).

This carrier base will occupy 7 tracks of the ML STAR instrument deck.



2.5.4.4 Operation of the Hamilton Heater Shaker

For operation of the HHS, a specific library is required (please refer to the [Microlab STAR Programmer's Manual](#) and the [HHS User Manual](#)).



ATTENTION

When working with samples used in particularly sensitive tests, take into account the evaporation that may occur while the HHS is running. Be aware that heating of liquids will affect the pipetting process, also shaking the labware can influence the precision of pipetting.



ATTENTION

When shaking labware, the speed has to be adjusted to the type of labware and the volume within the labware to prevent cross-contamination due to spillage.



ATTENTION

Do not touch the HHS while running, and shortly after finishing a run, as it might be hot. Wait until the HHS has cooled down to room temperature, which can take up to 1 hour.



NOTE

The maximum shaking speed of the HHS depends on the orbit and the type of labware used (see [Section 7.21 Hamilton Heater Shaker Specifications](#)).



NOTE

An efficient heating of the liquid is only achieved if the appropriate adapter for the labware is used. The heating time and the maximum temperature, which can be reached for the liquid inside the plate, is dependent on the amount of liquid, the size / weight of the used labware, the size / weight of the used adapter and the connection between the plate and the adapter.

Further information about the maximum shaking speed for MTPs and DWPs can be found in [Section 7.21 Hamilton Heater Shaker Specifications](#).

2.5.4.5 Loading Labware

The appropriate labware can either be loaded manually or automatically by using the iSWAP or the CO-RE gripper from the ML STAR or by other labware handling devices which can reach the labware on the HHS device.

2.5.5 Multiflex Heating and Multiflex Cooling Module

2.5.5.1 Overview

The Multiflex Heating Module heats microplates whereas the Multiflex Cooling Module cools microplates. The temperature range for the heating module is from ambient +5°C to 65°C. The temperature range for the cooling module is from 15°C to 4°C. A temperature selection dial is located on the top of each module for setting the desired temperature. The status LED “**OFF**” indicates the Multiflex Heating or Cooling Module is coming to temperature. When the LED is “**ON**”, the temperature of the Labware adapter is within ±1°C of the desired temperature. It is possible to place up to 4 Multiflex carriers on one ML STAR instrument.



Multiflex Heating Module



Multiflex Cooling Module



ATTENTION

Do not touch the Multiflex heating module during run time and shortly after finishing a run. Wait until the Multiflex heating module has cooled down to room temperature, which can take up to 1 hour.

2.5.5.2 Installation of the Multiflex Heating Module and Multiflex Cooling Module

Generally; the Multiflex Heating Module and Multiflex Cooling Module will be installed by a Hamilton trained field service engineer.



ATTENTION

When placing the Multiflex heating module or the Multiflex cooling module on the deck, one track position must remain empty on each side of the module for air circulation. The modules must not be placed next to each other on the deck. Extra spacing between modules is necessary to allow for proper ventilation.



NOTE

An efficient heating/cooling of the liquid is only achieved if the appropriate adapter for the labware is used. The heating/cooling time and the maximum/minimum temperature which can be reached for the liquid inside the labware is dependent on the amount of liquid, used type labware, the used adapter and the connection between the labware and the adapter.

The temperature is measured on the labware adapters. Because of the liquid containers and the ambience, there is a temperature deviation (ΔT) between the labware adapter and the liquid.

Typical cooling / heating deviation in the liquid (water) compared to the desired temperature:

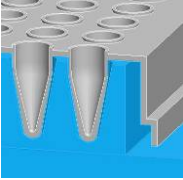
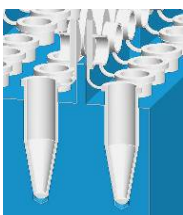
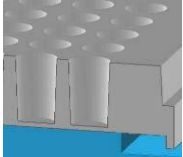
Labware	Adapter	ΔT Cooling (0 °C)	ΔT Heating (99 °C)
PCR plate		$\leq 0.5^{\circ}\text{C}$	$\leq 1.0^{\circ}\text{C}$
Eppendorf tubes		$\leq 0.5^{\circ}\text{C}$	$\leq 1.0^{\circ}\text{C}$
MTP (flat bottom)		$\leq 3.0^{\circ}\text{C}$	$\leq 5.0^{\circ}\text{C}$

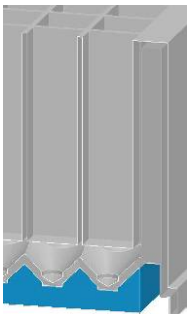
DWP (U-bottom)		$\leq 5.0^{\circ}\text{C}$	$\leq 7.0^{\circ}\text{C}$
----------------	-----------------------------------------------------------------------------------	----------------------------	----------------------------

Typical time (at 40% relative humidity, $T_{\text{ambient}} \approx 22^{\circ}\text{C}$, $T_{\text{liquid}} \approx 22^{\circ}\text{C}$) to heat (ambient $+5^{\circ}\text{C}$ to 65°C) and cool (15°C to 4°C) is from 5 to 20 minutes.

The Multiflex Lid Parking Module can be used for parking the Multiflex Heating/Cooling Module lid.

2.5.6 Multiflex Cooling-Heating Module

Generally; the Multiflex Cooling-Heating Module will be installed by a Hamilton trained field service engineer.



Multiflex Cooling-Heating Module

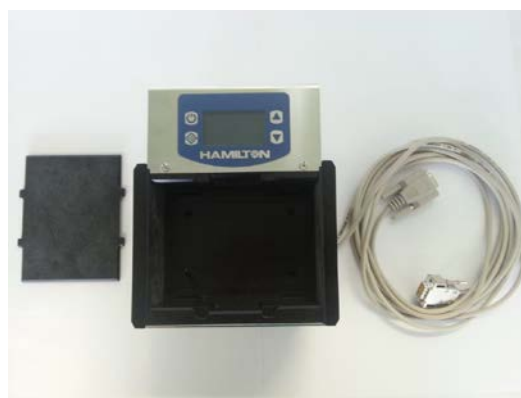

Contents of the Cooling-Heating Module for Installation



ATTENTION

When placing the Multiflex Cooling-Heating Module on the deck, one track position must remain empty on each side of the module for air circulation. The modules must not be placed next to each other on the deck. Extra spacing between the modules is necessary to allow proper ventilation.

The intended use of the Multiflex Cooling-Heating Module is to cool down or heat up a labware and keep it at that defined temperature. It is not a thermocycler and not a standalone module.

The temperature range for the Cooling-Heating Module is 4°C to 95°C. An automated touch pad with a graphical user interface display is located on the top of the module to set the temperature. The touch pad illuminates once it has been turned on. It is also possible to control the module by a library from the Venus Software. The module has a dry mode feature which dries out the instrument. Adapter plates are available to accommodate labware.



ATTENTION

Do not touch the Cooling-Heating Module during run time and also not shortly after finishing a run, as it might be hot. Wait until the Cooling-Heating Module has cooled down to room temperature, which can take up to 1 hour.



ATTENTION

Do not use module for cooling in continuous operation as condensate could damage the module. Apply dry mode at the end of a run if cooling was used.



ATTENTION

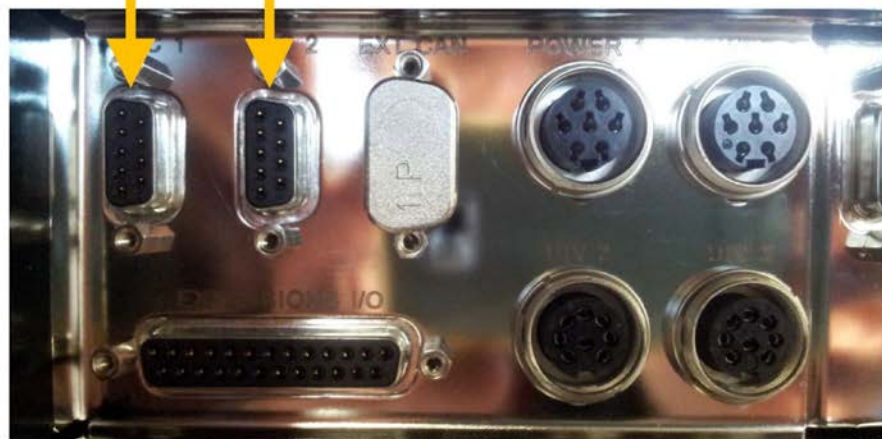



ATTENTION

Plate transport parameters must be adapted according to used labware to avoid a collision between the gripping tool and the walls and bottom of the Cooling-Heating Module.



ATTENTION

Use a plate specific lid to avoid contamination between wells and different plates.

2.5.7 On Deck Thermo Cycler (ODTC)

The ODTC is for “on deck” integration, a superior quality product from INHECO adapted for the Hamilton liquid handling instrument line. Any molecular biological workflow that needs repeated heating or cooling steps can be realized.

- Easy integration without any deck modification
- Ideal for genomics workflows like PCR & NGS
- Up to 2x ODTC per carrier
- Up to 4 ODTC per instrument
- Runtime < 40 min for 40 cycles
- Labware: 96-well PCR plates low profile, hard shell, skirted
- Temperature: 4°C up to 99°C
- Heating 4.4°C/sec.
- Cooling 2.2°C/sec.
- 40 cycles < 40 min.
- Load/unload: manually / CO-RE gripper (iSWAP)



2.5.8 Freezer Carrier

On-deck freezer carrier with two chambers for labware (microplate, microtubes, plate frames) in SBS format. Temperature range -20°C – +50°C. The cooling/heating is performed by a Stirling engine and does not require any tubing, cryostat or cooling agents.

The freezer carrier is in total 11 T wide (10T for the module, 1T for air circulation) and requires space below the deck to accommodate the Stirling engine. A level 2 integration is required.

- Labware: Standard and Customized
- Temperature: -30°C up to ambient
- Control: manual or by hsl Library
- Load/unload: manual / CO-RE gripper

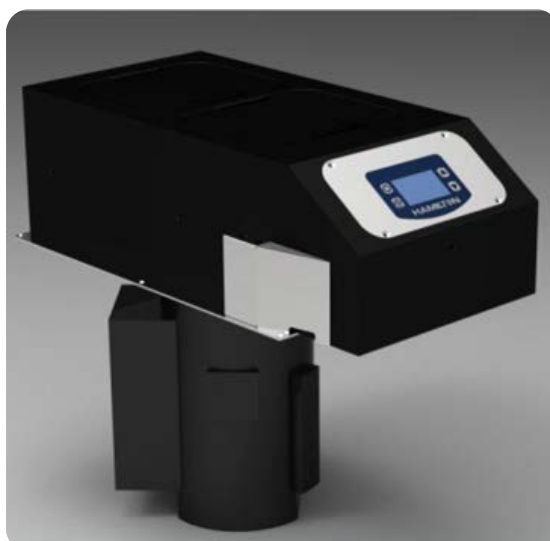

ATTENTION

Due to the design of the carrier, it can only be placed in certain positions on the deck and requires a special table. Also multiple tools are required for operation (power box, CO-RE grippers). Contact APE for further information!

2.5.9 CR Needle Wash Station and Pump Unit

2.5.9.1 CR Needle Wash Station

The CR Needle Wash Station is a device for the washing of up to 24 steel needles in parallel to the pipetting process. The wash station has the width of a standard microplate carrier (6 tracks), and up to two needle wash stations can be mounted on the ML STAR instrument deck. The carryover of the wash station depends on the wash settings. Typical values are 10^{-5} to 10^{-6} . A set of default parameters is given for the wash process within the relevant dialog boxes of the VENUS Software. Wash parameters can be adapted.

Each wash station (item 1) is supplied with a pump station (item 2) with two reservoir containers (item 3) for wash solutions and one waste container (item 4). The wash and the waste containers have a capacity of 12 liters. LLD is provided in the wash containers to indicate when they are near empty and in the waste container to indicate when it is near full. The pump station is placed under the bench of the instrument.

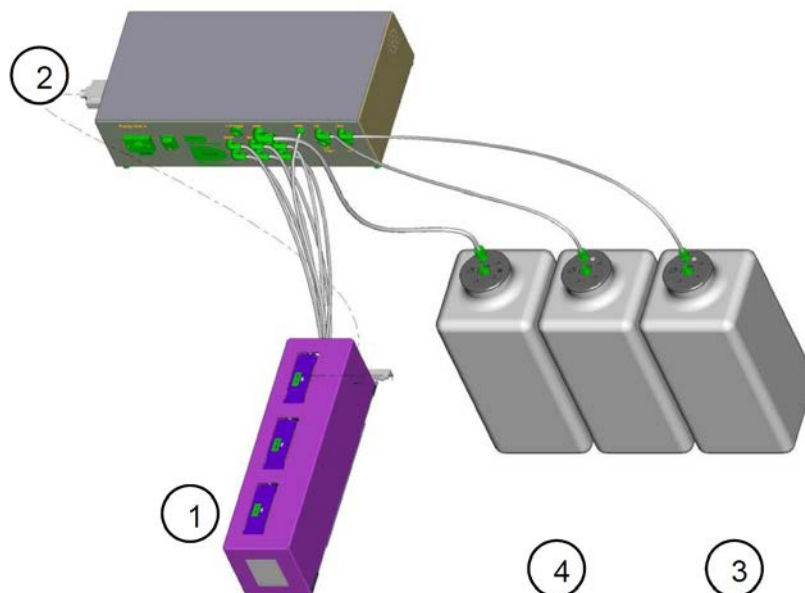

The wash station consists of three individual 8-fold wash modules. The modules are able to wash the 1000 μ l needles, 300 μ l needles or the 10 μ l needles. Within one wash station module all 3 needle types can be washed.

The wash cycle works in parallel to the pipetting steps. In case of an 8-pipetting channel instrument, the following steps can take place:

1. The needles from the first module are picked up; they are used for pipetting, and then placed back into the same module. Needle washing starts.
2. While the needles of the first module are washed, the needles from the second module are picked up. After pipetting these needles are placed back into the second module. The wash cycle of this module is started parallel to the next steps.
3. While the instrument starts pipetting with the needles of the third module, the first module has finalized needle washing. After pipetting the needles are placed back into the third module. Then the wash cycle of this module can start.
4. Clean needles are picked up from the first module again. The process is then repeated.

The principle of the wash station is illustrated in the following figure which shows a typical procedure.

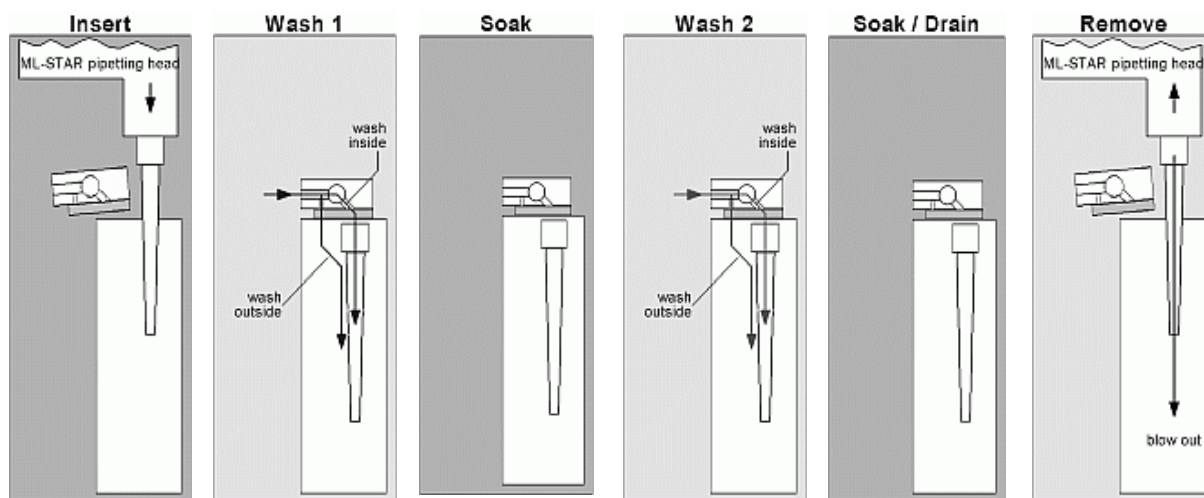

Schematic drawing of needle wash process: needles are placed into the wash module, washed from inside and along the outside using 1) wash and 2) rinse solution. The pipetting channels blow air through the needles to expel any residual liquid.



NOTE

Disposable tips may not be used in the needle wash station.

Hamilton recommends replacing the needles every 6 months.

For a 16-pipetting channel instrument, two independent wash stations are necessary to enable high-throughput pipetting with one needle type.



NOTE

A table of chemical compatibilities with the wash station can be found in [Section 8.1 Chemical Compatibility](#). The information provided is based on laboratory tests with raw materials and should be interpreted as a guideline only.

Consider local regulations for handling and storage of wash liquids regarding toxicity, contamination, fire protection, etc.



ATTENTION

The needle wash station for the ML STAR is not explosion-proof. When working with flammable or explosive fluids or vapors, necessary precautions must be taken.

A Hamilton trained field service engineer must perform the installation of the Needle Wash Station.

2.5.9.2 CR Needle Wash Station Pump Unit

The CR Needle Wash Station Pump Unit includes two wash pumps and one waste pump. The wash pumps fill the wash chambers in the washer unit. The waste pump empties the wash chamber and/or the overflow chamber.

The Pump Unit for the Needle Wash Station has its own power supply. The main plug is on the rear of the pump station (see picture below).

Ensure that the needle wash station is correctly grounded when connected to the electrical outlet.

Ensure that the voltage selector on the pump station of the needle wash station is correctly set before operating the needle wash station. The needle wash station does not automatically switch for different voltage levels (115 VAC or 230 VAC).

The fuses for the pump station are located in the main socket (see picture below). The pump station has two fuses for the power supply which can be accessed by opening the cover underneath the main socket.



The technical specifications regarding electrical power and fuses to be used for the wash station are listed in [Section 7.13 CR Needle Wash Station Specifications](#).

2.5.10 Dual Chamber 96/384 Wash Station

The Dual Chamber 96/384 Wash Station is an optional device for washing disposable tips of the CO-RE 96 and 384 Probe Heads. Low volume CO-RE tips, 50µl volume CO-RE tips, standard volume CO-RE tips, 300µl Rocket Tips, and high volume CO-RE tips without filter can be washed.



NOTE

Washing of filter tips is not recommended and not intended because there is a risk of contamination and a risk of damage to the pipetting device.

Washing takes place by aspirate/dispense cycles with the CO-RE 96 Probe Head or the CO-RE 384 Probe Head respectively.

The wash station has the width of 6 tracks and is mounted on the ML STAR instrument deck. Two wash chambers make the process of washing tips efficient. Each chamber can be filled individually with wash liquid out of two source containers.

Each wash station (item 1) is supplied with a pump station (item 2) with two reservoir containers (item 3) for wash solution and one waste container (item 4). Both the wash and the waste container have a capacity of 12 liters. LLD is provided in the wash containers to indicate when they are near empty and in the waste container to indicate when it is near full. The pump station is placed under the bench of the instrument.

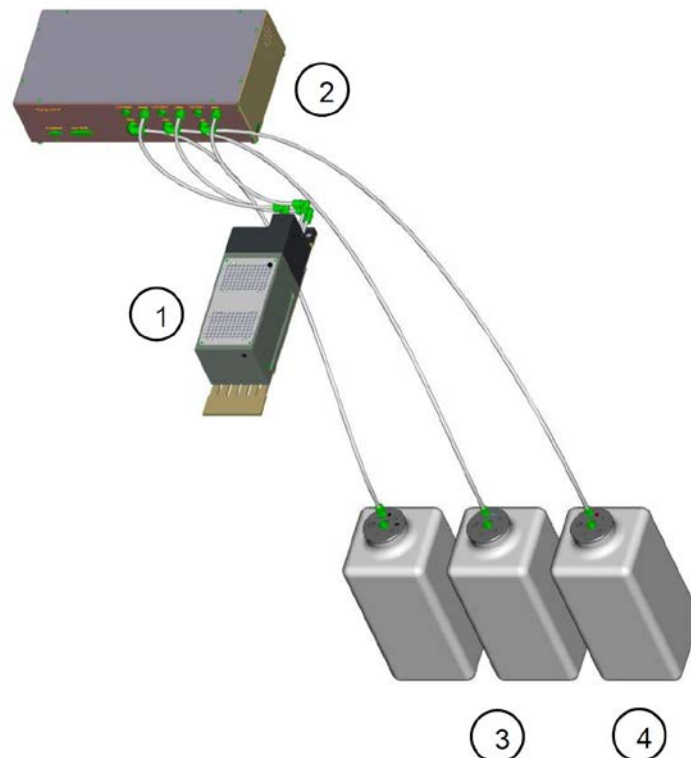

The pump unit includes two wash pumps and one waste pump. The wash pumps fill the wash chambers in the wash station. The waste pump empties the wash chamber and/or the overflow chamber.



NOTE

When re-filling the wash liquid container the waste liquid container must be emptied as well.

When re-using washed tips, pipetting precision may decrease.



ATTENTION

Only use water or DMSO maximum 30%, as wash liquid for the wash station.



ATTENTION

The wash station for the ML STAR instruments is not explosion-proof. When working with flammable or explosive fluids or vapors, necessary precautions must be taken.



NOTE

Older versions of wash stations, i.e. the 96 chamber wash station and the 384 dual chamber wash station are tip pattern specific!

If 50µl tips of the 384 Probe Head need to be washed in these older versions, the 384 dual chamber wash station must be used.

If Rocket Tips need to be washed in these older versions, the 96 chamber wash station must be used.

There is the possibility to field-upgrade an old version Wash Station to the Wash Station 96 / 384 Dual. Please consult a local Hamilton representative for this possibility.

2.5.11 Temperature Controlled Carrier (TCC)

The Temperature Controlled Carrier (TCC) is a device for heating and cooling microplates. It is designed to function as a drawer. The TCC has a capacity of four positions for microplates. The temperature is the same on all positions. The heating function of the TCC reaches temperatures of up to 60°C, while cooling microplates down to 22°C below ambient temperature is possible. Up to two TCC's can be installed on one instrument.

TCC consists of the heating/cooling plate carrier fixed on the ML STAR instrument deck. The external heat exchanger device is placed below the bench. The working fluid in the refrigeration cycle is a synthetic liquid.

Typical times (at 40% relative humidity) to heat or cool a microplate is ($T_{\text{ambient}} \approx 20^{\circ}\text{C}$):

T_{ambient} to 60°C	~ 20 min
60°C to T_{ambient}	~ 20 min
T_{ambient} to 4°C	~ 15 min
4°C to 60°C	~ 25 min



The Temperature Controlled Carrier (TCC)

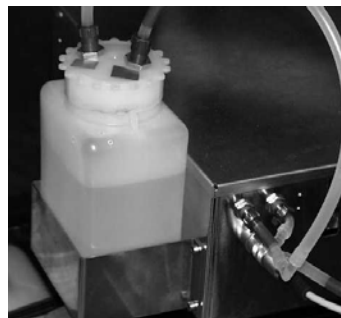

The Heat Exchanger Liquid Reservoir



NOTE

Ensure there is always enough liquid (minimum 1 liter) within the reservoir.

Allow air exchange between the exchanger and ambient air.

The default position of the TCC is loaded on the ML STAR instrument deck. Always ensure that the TCC is loaded on the deck at the beginning of the loading process. Never leave the TCC unloaded on the loading tray.

Given the TCC's fix-mounted chassis and movable carrier slide, do not use Smart Steps to load a TCC with the Autoload function. The Autoload slide may collide with the TCC carrier slide.

The installation of the Temperature Controlled Carrier (TCC) must be performed by a Hamilton trained field service engineer.

2.5.12 Crystal Vacuum System

2.5.12.1 Overview

The Crystal Vacuum System (CVS) replaces the older Basic Vacuum System (BVS) and allows automation of vacuum based kits for SPE, LC-MS, genomics and proteomics. CVS consists of a 7-track-wide carrier base equipped with the vacuum manifold, the park position for the manifold top and two microplate positions. By default the manifold top and insert for standard filter plates are included. For processing deep well filter plates, the deep well kit is required. The DWP Kit can be found in [Section 8.2 Ordering Information](#).

The manifold top can be handled either by the iSWAP (see [Section 2.4.7 iSWAP](#)) or the CO-RE gripper (see [Section 2.4.14 CO-RE Gripper](#)). If working with the iSWAP, four tracks next to the CVS carrier have to be empty, usually on the right side.

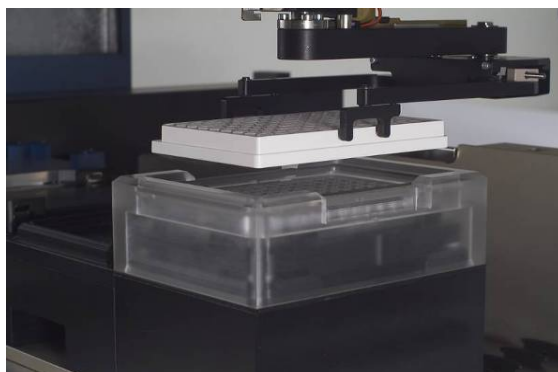

The iSWAP in action to load a filter plate to the CVS

The CVS accommodates a wide variety of 96-well and 384-well filter plates. With the height adjustable inserts inside the vacuum chamber, almost any kind of elution plates can be used. Four sets of nuts and bolts are included for adjusting the height as required.

The CVS carrier is mounted on the ML STAR instrument deck. It is possible to place up to four CVS carriers on one instrument.



NOTE

The Crystal Vacuum System is dependent on the elution plate's depth. If it deeply recessed, there is a need for it to be handled with the CO-RE grippers.

“Standard” Formats:



Deep Formats:



2.5.12.2 Crystal Vacuum System Installation

A Hamilton trained field service engineer must perform the installation of the CVS Vacuum System. The vacuum is generated with the Vacuubrand pump. The pump unit is fully integrated into the VENUS Software. For precise control, the vacuum inside the chamber of the CVS can be monitored.

2.5.12.3 Vacuubrand Pump

The vacuum inside the chamber of the CVS is generated with the Vacuubrand pump. The maximum flow rate of the pump is $\sim 5 \text{ m}^3/\text{h}$, and the possible final vacuum $\sim 80 \text{ mbar}$. There is a built-in sound absorber that considerably reduces the pump noise level.

The vacuum controller CVC 3000 regulates the pump. Communication with the computer is via an RS232 cable, and its software is seamlessly integrated into the VENUS Software.



Vacuubrand Pump



Controller CVC 3000

The air-bleed valve and the pressure sensor are both mounted inside the CVS carrier.

2.5.12.4 Waste Bottle for BVS / CVS

The CVS has to be connected either to a suitable in-house liquid disposal system or to a Hamilton waste bottle which collects liquid that is extracted during the vacuum step. The waste bottle is connected to the vacuum chamber and to the pump unit. Waste bottles come assembled with a bucket which prevents spillage in case of leakage.



BVS / CVS Waste Bottle 4L in a Bucket



NOTE

When using alternative Waste systems, be aware that bottles and tubing's may be exposed to a differential pressure of approximately -1 bar.

The BVS / CVS waste bottles are not part of a CVS, they have to be ordered separately. Please refer to [Section 8.2 Ordering Information](#). One 4 liter waste bottle is available. The waste bottle should be placed below the instrument.

2.5.12.5 Shaker on the CVS

Optionally, the rear microplate position can be replaced by a Hamilton Heater Shaker or by third party heater shakers. The list of available modules can be found in [Section 8.2 Ordering Information](#).

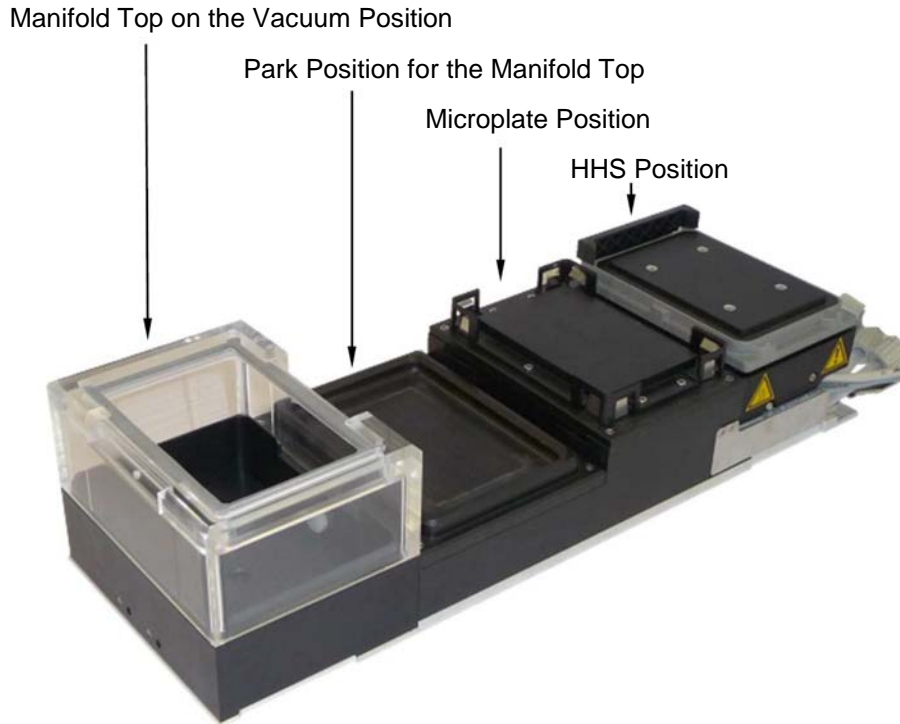

Hamilton Heater Shaker on the CVS

The Hamilton Heater Shaker will be installed by a Hamilton trained field service engineer. The CVS Carrier comes with a metal plate for fixation for the heater shaker cables and tubing, it must be retained in a safe place, including screws for mounting, for a later retrofit of a heater shaker.

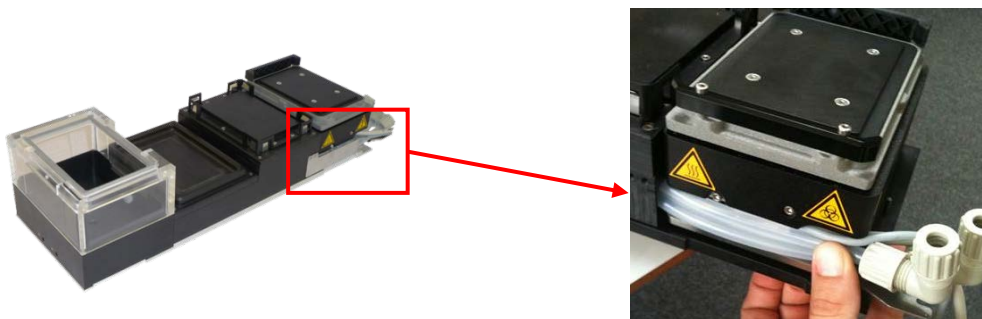

Position of the metal plate on the CVS Carrier for fixation of heater shaker cables and tubing

HHS, tubing and cables, shown before fixation by the metal plate

2.5.13 HEPA Filter Hoods

The ML STAR instruments can be retrofitted with a HEPA (*H*igh *E*fficiency *P*articulate *A*ir) Filter Hood for air filtration. The HEPA Filter Hood creates a laminar flow of filtered air from the top of the instrument to the deck surface. Room air is drawn in from the top and forced through a one stage filter. The air is discharged from the filters over the pipetting area inside the instrument and exits through the opening in front and vents in the acrylic glass cover on the back of the workstation to protect the assay from the environment outside the workstation. The flow rate of 0.3 m³/s is comparable to that of other commercially available flow cabinets making adaptations of the instrument for work under aseptic conditions possible (e.g. for mammalian cell culture).

Form fitting hoods are available for all three sizes of the STAR. The two HEPA Filter Hoods mounted on the ML STARPlus can be controlled individually.



ML STARlet with HEPA Filter Hood

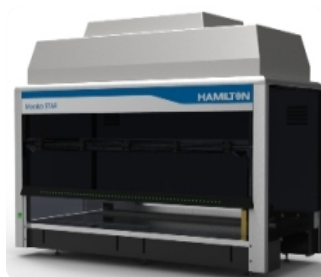

ML STAR with HEPA Filter Hood

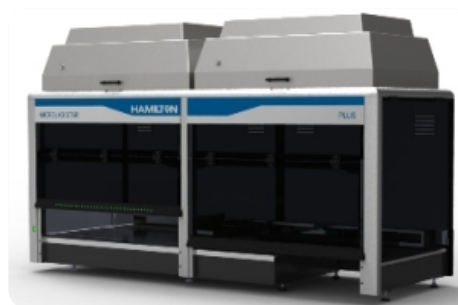

ML STARPlus with HEPA Filter Hood

Class II isolation enclosures are also available from third party supplies to enclose the entire workstation if the environment outside the workstation needs to be isolated from the assay.

Air flow volume can be controlled by the software running the workstation to alter conditions while running the assay. The on/off switch is mounted to the hood itself as well.

Volumetric Flow	Software Settings
89.39 cfm 2.53m ³ /min	20%
380.65 cfm 10.78m ³ /min	50%
832.63 cfm 23.58m ³ /min	100%



NOTE

The Hamilton HEPA Filter Hood is designed to draw ambient air in through the filter assembly and to provide an enclosed, 'clean air zone' within the ML STAR instrument workstation pipetting environment. For more information about the HEPA Filter Hood, please refer to the HEPA Filter Hood Manual.

A UV light option is also available to further reduce germ count inside the instrument (e.g. before and after a working day). When retro-fitting the UV option, the instrument covers should be exchanged from those made of standard acrylic glass to a UV resistant acrylic glass.

2.6 Tips and Needles

Hamilton offers a large variety of disposable tips and steel needles for use with the pipetting channels and MPH heads.

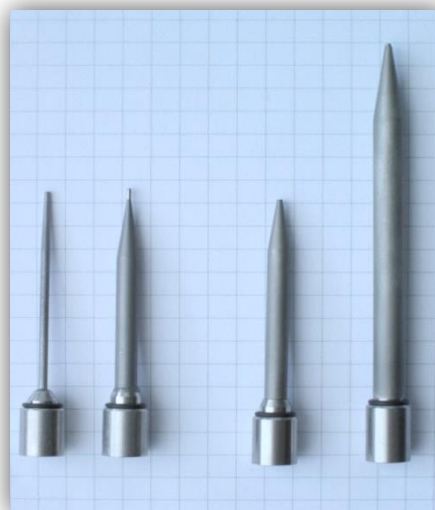
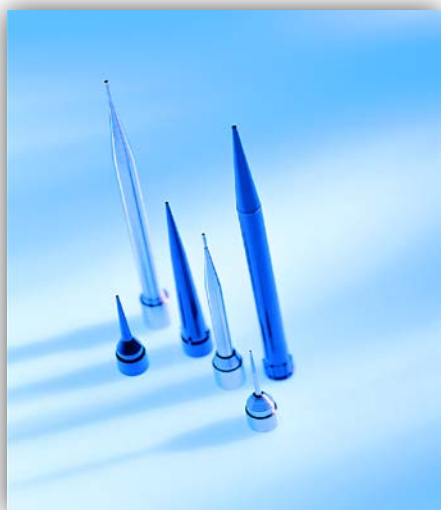

Hamilton Disposable Tips and Steel Needles for the ML STAR

Left to right: Low Volume (10µl), 50µl, Standard Volume (300µl), and High Volume (1000 µl) Disposable Tips; 10µl, 300µl, 1000µl Steel Needles

Hamilton's CO-RE tips are the only tips designed to work with the ML STAR instruments developed to meet the demands of the most flexible and reliable automated pipetting tasks. The pipetting channels lock into the tip rather than the standard method of forcing a tip on a mandrel (see [Section 2.1.2 Tip Pick-up with the CO-RE Technology](#) for the CO-RE technology). This design assures superior tip alignment, seals the tip to the pipette channel, eliminates tip distortion, and mitigates aerosol contamination.

The use of non-Hamilton tips is not supported on the ML STAR instruments. Non-Hamilton tips do not have the annular space to receive the O-ring. This may result in non-intended deformation of the O-ring and the tip material itself. It may lead to misalignment of the tip, improper sealing, reduced O-ring life, improper drop-off, and potential aborted runs from randomly dropped tips. Therefore, Hamilton does not support the use of non-Hamilton tips on the ML STAR instruments.



ATTENTION

Only Hamilton needles and disposable tips should be used for coupling to the pipetting channels and pipetting heads of the ML STAR instrument. Other tips may cause contaminated or damaged pipetting channels.

**NOTE**

Pipetting specifications are only guaranteed when using Hamilton Tips.

Hamilton's proprietary technologies for tip attachment (CO-RE) and air displacement pipetting together with the use of Hamilton tips facilitate maximum pipetting accuracy and reliability.

Hamilton disposable CO-RE tips are produced under clean room conditions (class 8), based on ISO 14644 standards. "Biological purity tested" tips are free of DNA, DNase/RNase, PCR inhibitors and endotoxin (non-pyrogenic). In addition to these criteria, "Biological purity^{PLUS}" tips are sterile, according to ISO 11135, and free of ATP.

Filter tips are available for preventing aerosol contamination.

Clear tips are available as well as conductive (black) tips specifically designed for cLLD.

**NOTE**

Make sure to match the tip type(s) used with the method and channel(s) / probe head(s). Please refer to [Section 2.1.3 Tip Recognition](#).

**NOTE**

Be aware that different tip classes (with and without filter, black or clear, non-sterile versus irradiated, etc.) can have different performance when pipetting liquids. Pipetting parameters and liquid class settings may have to be adjusted when changing from one tip type to another in order to achieve accuracy and precision which is within published specifications.

**NOTE**

All new or special tip types require additional settings (such as configuration file entries, liquid classes, etc.) in the VENUS Software. Please consult a local Hamilton representative for implementation of non-standard tips.

For ordering information see [Section 8.2 Ordering Information](#), or contact a local Hamilton representative.

2.6.1 Tip Packaging

All CO-RE disposable tip types are available in racks with a sealed paper lid (blister pack). The tip racks are barcode labeled for automatic identification during the loading process. All instruments equipped with a barcode reader are able to check for the proper tip type being loaded.

See [Section 8.2 Ordering Information](#) for a complete listing, or contact a local Hamilton representative.

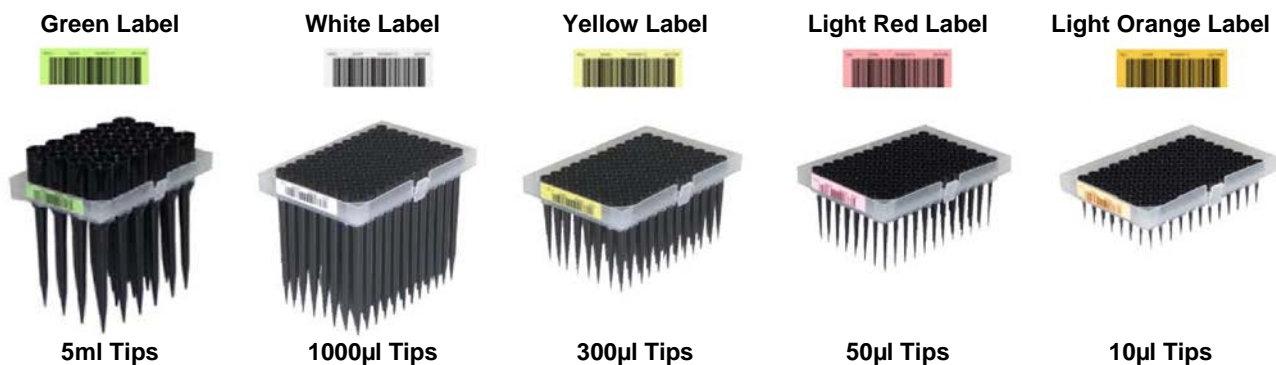

Examples of Barcode Labeled Tip Racks



NOTE

The tip type is printed in plain text on the barcode label of the tip rack for visual identification (e.g. "5ml" for the 5ml CO-RE tips).

Generally, blister packs contain several racks of 96 tips each. 5ml tips come in blister packs containing racks of 24 tips each.

CO-RE tips are available in boxes of 3840 high-volume tips (1000µl), 5760 standard-volume tips (300µl and 50µl) and 5760 low-volume tips (10µl).

The racks are compatible with the respective tip carriers.



Tip Carrier TIP_CAR_480 containing five Tip Racks

10µl, 50µl and 300µl CO-RE disposable tips without filters are stackable. These tip types are available in Nested Tip Racks (NTR). This high packing density and high number of tips make longer runs possible without reloading.



Nested Tip Racks (NTR's)

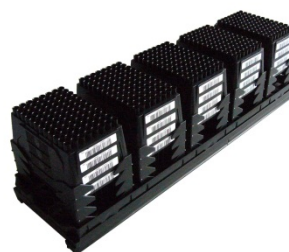

Five stacks of four NTR's each

The Nested Tip Rack (NTR) is designed to stack disposable tip racks which increase the amount of disposable tips by a factor of 4 per SBS position compared to one layer tip locations. NTR's come with 5 stacks of 4 layers each and have to be placed onto NTR carriers of the ML STAR instrument.

A transport system (e.g. iSWAP, CO-RE Gripper) is required to remove and dispose empty NTR frames away from the NTR Stacks to allow access with the Pipetting Tools to the next filled NTR.

Forcing Pipetting Tools to go down lower or to the lowest layer of the NTR stack may have limitations due to the required space between the Pipetting Tool and neighboring Carriers, as well as its corresponding labware (also to other stacks, neighbor NTR's, etc.). In these cases, an intermediate Tip pickup position becomes necessary. This intermediate tip pickup position is designed and available as an NTR Multiflex Module (MULTIFLEX NTR 96 MODULE, and MULTIFLEX NTR 384 MODULE).

The transport system, as mentioned above, must then be used to move NTR's to these intermediate tip pickup positions, which enables constant tip pickup conditions in terms of the same X, Y and Z coordinates of a single NTR. Once the tips out of the NTR frame of the intermediate tip pickup position are used up, the frame needs to be removed and replaced by a new filled NTR.

When single, row or column tip pickup is required with Multi Probe Heads, an additional tip pickup position equipped with a tip adapter is necessary. The tip adapter may be positioned onto a tip rack carrier as well as on a Multiflex tip module (MULTIFLEX TIP MODULE).

The recommended workflow would be:

1. Transportation of one NTR from a loaded NTR Carrier to the intermediate Tip pickup position.
2. Tip pickup with MPH out of the intermediate tip pickup position.
3. Tip eject into the tip adapter.
4. As desired; single, row or column (shifted) tip pickup out of the tip adapter.
5. Ready for pipetting.

2.6.2 Tips for Pipetting Low Volumes from 0.5-10 μ l

The low volume CO-RE tip, 0.5-10 μ l, is available as a conductive (black) tip for use with cLLD and as a clear tip. It can be used with 1000 μ l-pipetting channels and CO-RE 96 Probe Head / CO-RE 96 Probe Head TADM.

See [Section 8.2 Ordering Information](#) for a complete listing, or contact a local Hamilton representative.



*Clear and Conductive Low Volume CO-RE Tip,
0.5 – 10 μ l*



Light Orange Label



*Tip Rack and Color Code Label
for Low Volume CO-RE Tips, 0.5 – 10 μ l*

Low volume CO-RE tips, 0.5-10 μ l come in racks of 96 tips. One blister pack contains 5 racks. They are also available in the NTR Tip Rack Pack reload system with five stacks of four 96 tip racks in a blister pack.

2.6.3 Tips for Pipetting Sample Volumes from 1-50 μ l

The low volume CO-RE tip, 1-50 μ l, is available as a conductive (black) tip for use with cLLD, with or without filter and also as a clear tip. It can be used with 1000 μ l-pipetting channels and CO-RE 96 Probe Head / CO-RE 96 Probe Head TADM.

See [Section 8.2 Ordering Information](#) for a complete listing, or contact a local Hamilton representative.



*Clear and conductive Low Volume CO-RE Tip,
1 – 50 μ l*



Light Red Label



*Tip Rack and Color Code Label
for Low Volume CO-RE Tips, 1 – 50 μ l*

Low volume CO-RE tips, 1-50 μ l come in racks of 96 tips. One blister pack contains 5 racks. They are also available in the NTR Tip Rack Pack reload system with five stacks of four 96 tip racks in a blister pack.

**ATTENTION**

Caution when using the CO-RE tips, 1-50 μ l and CO-RE tips, 10-300 μ l on the same system. Do not mix up one tip type with the other during the process of loading the deck. The wrong tip causes either bad pipetting results or damaged pipetting channels.

Use the Autoload function for loading tip carriers or the tip type recognition feature of the VENUS Software. Please consult the local Hamilton representative for the specific library which is needed.

2.6.4 Tips for Pipetting Sample Volumes from 0.5-50 μ l Using the 384 MPH

The 384 head CO-RE tip, 0.5-50 μ l, is available as a conductive (black) tip for use with cLLD and also as a clear tip. It can be used with the CO-RE 384 Probe Head.

See [Section 8.2 Ordering Information](#) for a complete listing, or contact a local Hamilton representative.



Clear and Conductive 384 Probe Head CO-RE
Tip, 0.5 – 50 μ l



Light Red Label



NTR with 384 (left) and 96 (right)
384 Probe Head CO-RE Tips, 0.5 – 50 μ l

384 head CO-RE tips, 0.5-50 μ l come in NTRs of 384 or 96 tips per rack. The NTR's equipped with 96 tips per rack enable using the CO RE 384-Probe Head as a 96 channel pipetting head. The NTR pack reload system contains five stacks of four tip racks in a blister pack.



NTR pack containing five stacks of four 384 head CO-RE tip racks

2.6.5 Tips for Pipetting Sample Volumes from 10-300 μ l

The CO-RE tip, 10-300 μ l, is available as a conductive (black) tip for use with cLLD, with or without filter and also as a clear tip. It can be used with 1000 μ l-pipetting channels and CO-RE 96 Probe Head / CO-RE 96 Probe Head TADM.

It is compatible with Monitored Air Displacement (MAD) and Total Aspiration and Dispensing Monitoring (TADM).

See [Section 8.2 Ordering Information](#) for a complete listing, or contact a local Hamilton representative.



*Clear and Conductive CO-RE Tip,
10 – 300 μ l*



Yellow Label



*Tip Rack and Color Code Label
for CO-RE Tips, 10 – 300 μ l*

CO-RE tips, 10-300 μ l come in racks of 96 tips. One blister pack contains 5 racks. They are also available in the NTR Tip Rack Pack reload system with five stacks of four 96 tip racks in a blister pack.



ATTENTION

Caution when using the CO-RE tips, 1-50 μ l and CO-RE tips, 10-300 μ l on the same system. Do not mix up one tip type with the other during the process of loading the deck. The wrong tip causes either bad pipetting results or damaged pipetting channels.

Use the Autoload function for loading tip carriers or the tip type recognition feature of the VENUS Software. Please consult the local Hamilton representative for the specific library which is needed.

2.6.6 Tips for Pipetting Sample Volumes from 10-1000 μ l

The CO-RE tip, 10-1000 μ l, is available as a conductive (black) tip for use with cLLD, with or without filter. It can be used with 1000 μ l-pipetting channels and CO-RE 96 Probe Head / CO-RE 96 Probe Head TADM.

It is compatible with Monitored Air Displacement (MAD) and Total Aspiration and Dispensing Monitoring (TADM).

See [Section 8.2 Ordering Information](#) for a complete listing, or contact a local Hamilton representative.



*Conductive CO-RE Tip,
10 – 1000 μ l*



White Label



*Tip Rack and Color Code Label
for CO-RE Tips, 10 – 1000 μ l*

CO-RE tips, 10-1000 μ l come in racks of 96 tips. One blister pack contains 5 racks.



ATTENTION

Caution when using the CO-RE tips, 10-1000 μ l and Slim tips, 10-300 μ l on the same system. Do not mix up one tip type with the other during the process of loading the deck. The wrong tip causes either bad pipetting results or damaged pipetting channels.

Use the Autoload function for loading tip carriers or take extra care and identify the tip type by reading the label on the barcode when loading the tip carriers manually.

2.6.7 Tips for Pipetting Sample Volumes from 50-5000 μ l

The CO-RE tip, 50-5000 μ l, is available as a conductive (black) tip with or without filter. It can be used with 5ml-channels.

It is compatible with Monitored Air Displacement (MAD) and Total Aspiration and Dispensing Monitoring (TADM).

See [Section 8.2 Ordering Information](#) for a complete listing, or contact a local Hamilton representative.



*Conductive CO-RE tip,
50 – 5000µl*



Green Label



*Tip rack and color code label
for CO-RE tips, 50 – 5000µl*

CO-RE tips, 50-5000µl come in racks of 24 tips. One blister pack contains 5 racks. In addition, individually wrapped, preloaded 1T disposable racks of 4 tips each are available in which the tips are physically separated by individual sheaths. They ensure contamination free tip loading.

2.6.8 Special Tips: Rocket tip

The unique Rocket tip, 2-300µl, fits to four pipetting channels of a CO-RE 384 Probe Head in parallel and turns it into a 96 pipetting head on the fly. It is available as a conductive (black) tip for use with cLLD. Rocket tips can be used with Deep Well Plates and microplates with well diameters $\geq 3.7\text{mm}$.

See [Section 8.2 Ordering Information](#) for a complete listing, or contact a local Hamilton representative.



Rocket tip, 2-300µl

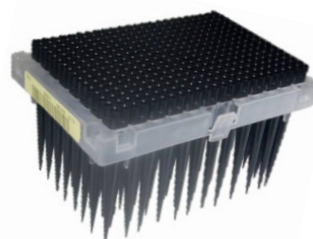

Yellow Label



*Tip rack and color code label
for Rocket tips, 2-300µl*

Rocket Tips, 2-300µl are packaged in racks of 96 tips per rack. One blister pack contains 5 racks.

2.6.9 Special Tips: Piercing Tip

The robotic piercing tip, 2-250µl is optimized for use with various sealed labware which can be pierced by applying a force of $\leq 10\text{ N}$. The special tip design is compatible with most commercially available seals.

The tip is available as a conductive (black) tip for use with cLLD, with or without filter. It is compatible with Monitored Air Displacement (MAD) and Total Aspiration and Dispensing Monitoring (TADM).

See [Section 8.2 Ordering Information](#) for a complete listing, or contact a local Hamilton representative.



Piercing tip, 2-250 μ l



Yellow Label



*Tip rack and color code label
for piercing tips, 2-250 μ l*

Piercing tips, 2-250 μ l come with 96 tips per rack. One blister pack contains 5 racks.

For piercing of tubes, additional equipment is required to hold the tubes in their position during the piercing process and to prevent them from being lifted when retracting the piercing tip. The fixation frame for this purpose is dependent on the labware used. It is mounted onto a MTP park position (P/N 188041) on a Multiflex carrier (P/N 188039). The standard fixation frame (P/N 188313) is designed for 1.4ml matrix tubes. For all other tube types, a customized fixation frame is required.

For piercing of plates, the Multiflex MTP fixation frame (P/N 188095) helps to lock the sealed plates in position on a Multiflex carrier during piercing.



*Fixation frame for 1.4ml matrix
tubes on a MTP park position
(P/N 188313)*



*Multiflex MTP fixation frame
on a MTP park position (P/N
188095)*



Multiflex Carrier (P/N 188039)



NOTE

In general, piercing is a challenge. It requires a fixation frame for the labware to be pierced and it is highly dependent on the shape of the needle or tip and the material and thickness of the seal. It is crucial that any piercing method is tested first before routine application.

2.6.10 Special Tips: Extra-long and Slim Tip

Extra-long and slim tips minimize the risk of liquid overflow in cluster tubes, Deep Well Plates and two-phased liquid applications. The Slim tip, 10-300 μ l reduces the displaced liquid volume by 40%.

compared to a CO-RE tip, 10-1000 μ l. The tip is available as a conductive (black) tip for use with cLLD, with or without filter. It can be used with 1000 μ l-pipetting channels and CO-RE 96 Probe Head / CO-RE 96 Probe Head TADM.

The Slim tip is compatible with Monitored Air Displacement (MAD) and Total Aspiration and Dispensing Monitoring (TADM).

See [Section 8.2 Ordering Information](#) for a complete listing, or contact a local Hamilton representative.



Slim Tip, 10-300 μ l



Yellow Label



*Tip Rack and Color Code Label
for Slim Tip, 10-300 μ l*

Slim tips, 10-300 μ l come with 96 tips per rack. One blister pack contains 5 racks.



ATTENTION

Caution when using the CO-RE tips, 10-1000 μ l and Slim tips, 10-300 μ l on the same system. Do not mix up one tip type with the other during the process of loading the deck. The wrong tip causes either bad pipetting results or damaged pipetting channels.

Use the Autoload function for loading tip carriers or take extra care and identify the tip type by reading the label on the barcode when loading the tip carriers manually.

2.6.11 Special Tips: Wide Bore Tips

For applications which require minimizing shear forces applied to the samples during pipetting, for highly viscous fluids or for particulate samples, Hamilton has designed CO-RE tips with various wide distal end orifices. The CO-RE tip wide bore 10-300 μ l with a length of 57.23mm which orifices size 0.71mm is a filter tip. The CO-RE tip wide bore 10-300 μ l with a length of 51.60mm which orifices size 1.55mm and the CO-RE tip wide bore 10-1000 μ l with a length of 80.14mm which orifices size 3.2mm are available with or without filter. Wide bore tips are conductive (black) for use with cLLD and they can be used with 1000 μ l-pipetting channels and CO-RE 96 Probe Head / CO-RE 96 Probe Head TADM.

Wide bore tips are compatible with Monitored Air Displacement (MAD) and Total Aspiration and Dispensing Monitoring (TADM).

See [Section 8.2 Ordering Information](#) for a complete listing, or contact a local Hamilton representative.

**Yellow Label**

Wide bore tip, 10-300 μ l,
orifice size 0.71mm

**Yellow Label**

Wide bore tip, 10-300 μ l,
orifice size 1.55mm

**White Label**

Wide bore tip, 10-1000 μ l,
orifice size 3.2mm

Wide bore tips come with 96 tips per rack. One blister pack contains 5 racks.

2.6.12 Needles

Steel needles can be used for pipetting instead of disposable tips in combination with a needle wash station when the application does not require an exchange of a tip. Needles are rinsed between pipetting tasks and are resistant to many chemicals (refer to [Section 8.1 Chemical Compatibility](#)).

10 μ l, 300 μ l and 1000 μ l needles are available for use with 1000 μ l-pipetting channels.

See [Section 8.2 Ordering Information](#) for a complete listing, or contact a local Hamilton representative.



NOTE

Hamilton recommends replacing steel needles every six months.

2.7 Computer Requirements

The ML STAR instrument is controlled by a dedicated VENUS Software which controls all functions for daily work routine, method programming, running methods, and other services.

Hamilton offers standard computers for the VENUS Software. For specifications, please refer to [Section 7.11 Hamilton Standard PC Specifications](#). For ordering information, please refer to [Section 8.2 Ordering Information](#).



NOTE

Computer requirements as well as operating systems described in this manual are subject to change without notice, respectively may become obsolete.

Depending on the ML STAR instrument configuration and processor board implemented, the following interfaces are available for linking the control computer (see [Section 2.9 Electronics and Interfaces](#)):

- a Serial Interface (RS-232C, with the Dual Processor Board)
- a Unified Serial Bus Interface (USB, with the Dual Processor Board or the LAN Dual Processor Board)
- Ethernet (with the LAN Dual Processor Board)

The communication interface used on the PC has to be set by the configuration editor. For further information about the recommended PC model, refer to [Section 7.1 Basic ML STAR Specifications](#).

To avoid data loss, using of an Uninterruptible Power Supply (UPS) for the PC is recommended.

2.8 VENUS Software

The VENUS Software provides everything to control an ML STAR instrument.

It is a Windows™-based, menu-driven interface allowing the user to define deck layouts and methods, and then to run the instrument.

The VENUS Software allows programming and running different methods for aspirating and dispensing liquids, also to control accessories such as a wash station, etc.

It is possible to upgrade from previous software versions to VENUS four. A software upgrade requires compatible firmware.



NOTE

ML STAR functionality has been verified using Windows 7 and Windows 10. Running the instruments under any other operating system may lead to severe problems and/or malfunction. Each programmed method should be validated by the programmer.

For more details refer to the [Microlab STAR Programmer's Manual](#). If not using a Hamilton computer, the customer needs to ensure that a suitable control PC is available for installation of the VENUS Software. The ML STAR instrument will be unpacked and installed and the initial set-up will be performed by a Hamilton trained field service engineer according to the IQ Form 610911.

2.9 Electronics and Interfaces

All the electrical connections are placed on the left side of the instrument, as shown below.

2.9.1 Interfaces of the Dual Processor Board

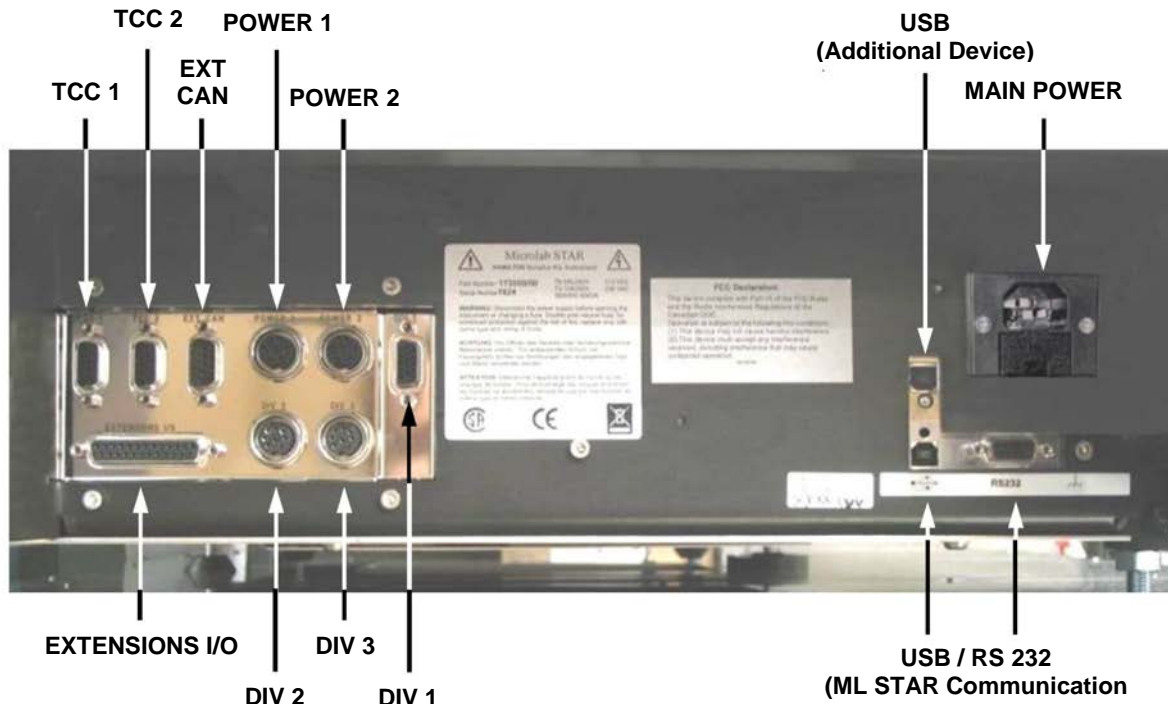

Interfaces of the Dual Processor Board

The main power connection is located near the front of the instrument (on the right side in the picture above). The communication connections to the PC are positioned beneath this main power connection. The ML STAR can communicate either via USB (the preferred option) or via RS232. A second USB connection is reserved for an additional device (e.g. an optional CCD Camera).



ATTENTION

Never use both connections, USB and RS232 together!



ATTENTION

Do not attempt to install a 3rd party device via the electrical connections of the ML STAR instrument on your own! Always consult a local Hamilton representative for installation.

Various connections for external devices are available. Up to two Temperature Controlled Carriers (TCC's) or Hamilton Heater Shakers can communicate and be powered via the connectors labeled "TCC 1", "TCC 2".

The CR Needle Wash Station is connected with the "EXT CAN" connector.

The "POWER 1" and "POWER 2" connectors provide different power supply voltages and also a CAN bus for communication.

The "DIV 1", "DIV 2", "DIV 3" connectors, and the "EXTENSIONS I/O" connector deliver several digital input/output signals as well as pulse-width-modulated (PWM) outputs, CAN Bus and TTL levels.

2.9.2 Interfaces of the LAN Dual Processor Board

Depending on the configuration, some ML STAR instruments are configured with a LAN Dual Processor Board (e.g. in combination with a CO-RE 96 Probe Head TADM). The electrical connections of these instruments are as shown below:

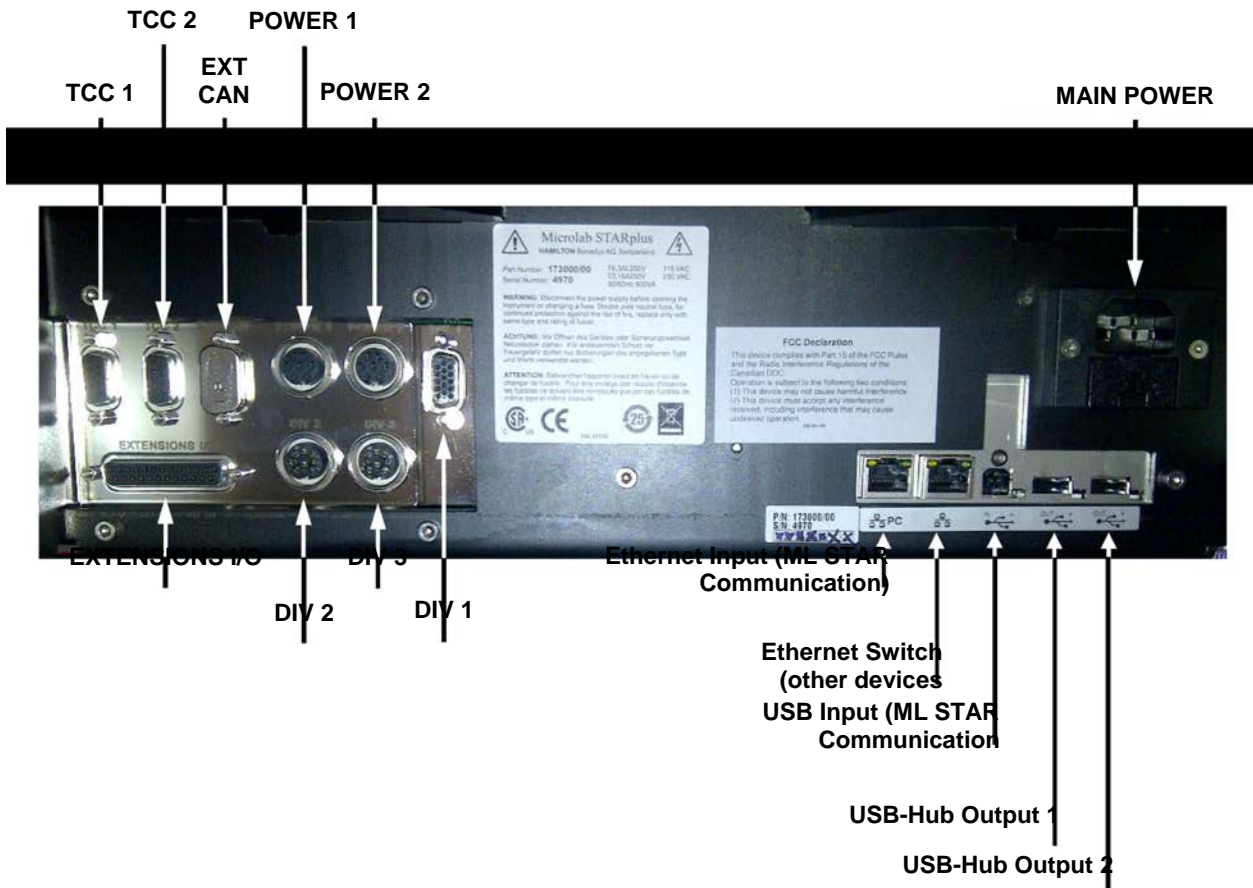

Interfaces for the LAN Dual Processor Board



NOTE

With the LAN Dual Processor Board installed, an RS232 connection is no longer provided.

For further details on all connections, please consult a local Hamilton representative.

2.10 ML STAR Power / Voltage

Make sure that the instrument is connected to a 115 or 230 VAC (50 Hz or 60 Hz) socket. The ML STAR automatically recognizes any voltage within that range, without user intervention.

We recommend using an Uninterruptible Power Supply (UPS) for the ML STAR instrument.

Ensure that the instrument is correctly grounded when connected to the electrical outlet.

The main plug is on the left-hand front side of the instrument.

The fuses for the instrument are placed in the main power socket (see picture below). During installation / IQ, the appropriate fuse is selected by a Hamilton trained field service engineer.

Plug the main cables for the computer and the instrument into the same electrical outlet. Connect them only to a grounded outlet.

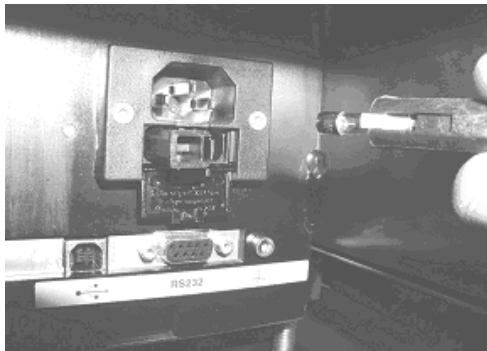
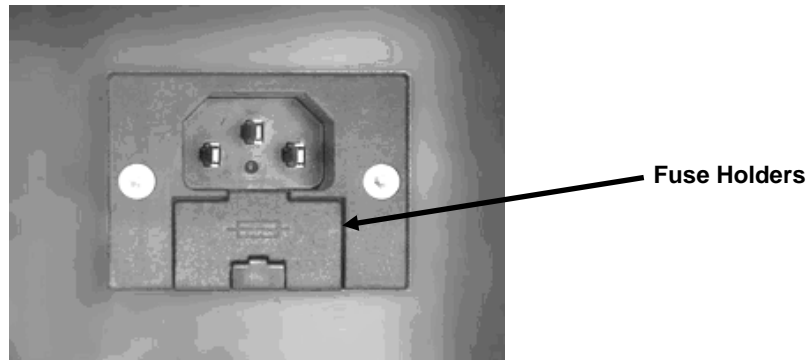

ATTENTION

When replacing a fuse, make sure to use the appropriate fuse (see [Section 7.1 Basic ML STAR Specifications](#)) and place it into the main power switch before switching on the instrument.

3. Routine Use

3.1 Loading the ML STAR Instrument

To run a method:

1. To access the Run Control, double-click the “Microlab STAR Run” shortcut on the desktop:



2. From the File menu of Run Control, select “Open”, to open a method (*.med). The method is now loaded:

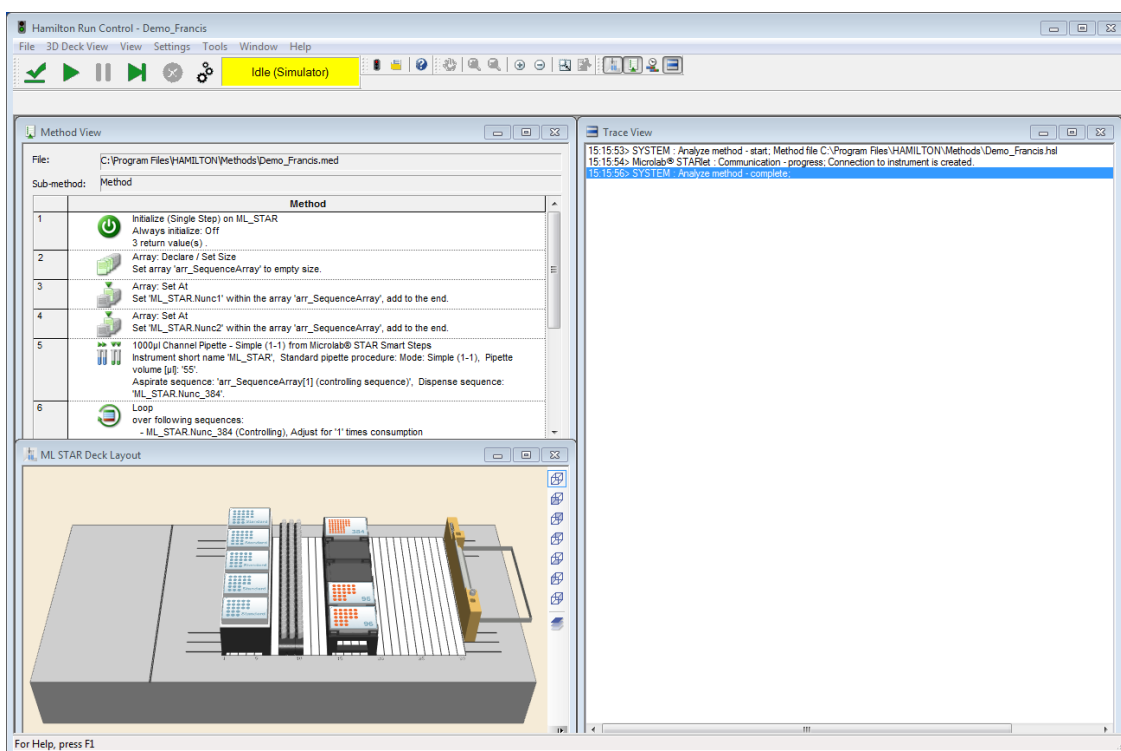

3. The free area visible after starting “Run Control” can display multiple windows:

- Deck View
- Method View
- Trace View
- Schedule View
- HSL Debugger (if installed)
- Watch View (if HSL Debugger is installed)

4. The windows may be enabled/disabled by means of the “Run Views” menu (click the desired menu entry)

or

by clicking on the appropriate icon in the “Run Views” toolbar  (if enabled).

5. Arrange the windows according to preference using the “Window” menu. In the window shown above, the deck layout and the method log (trace) of a run as it is generated are shown.
6. Press the [Start] button (the one which looks like a [Play] button)



to run the method. The steps in the method are traced to the log frame.

7. If a loading step is part of the method, a dialog appears that requests a reduction of the number of positions (e.g. on the sample carrier), as well as a start position for the tips to be picked up. Both pieces of information are optional.

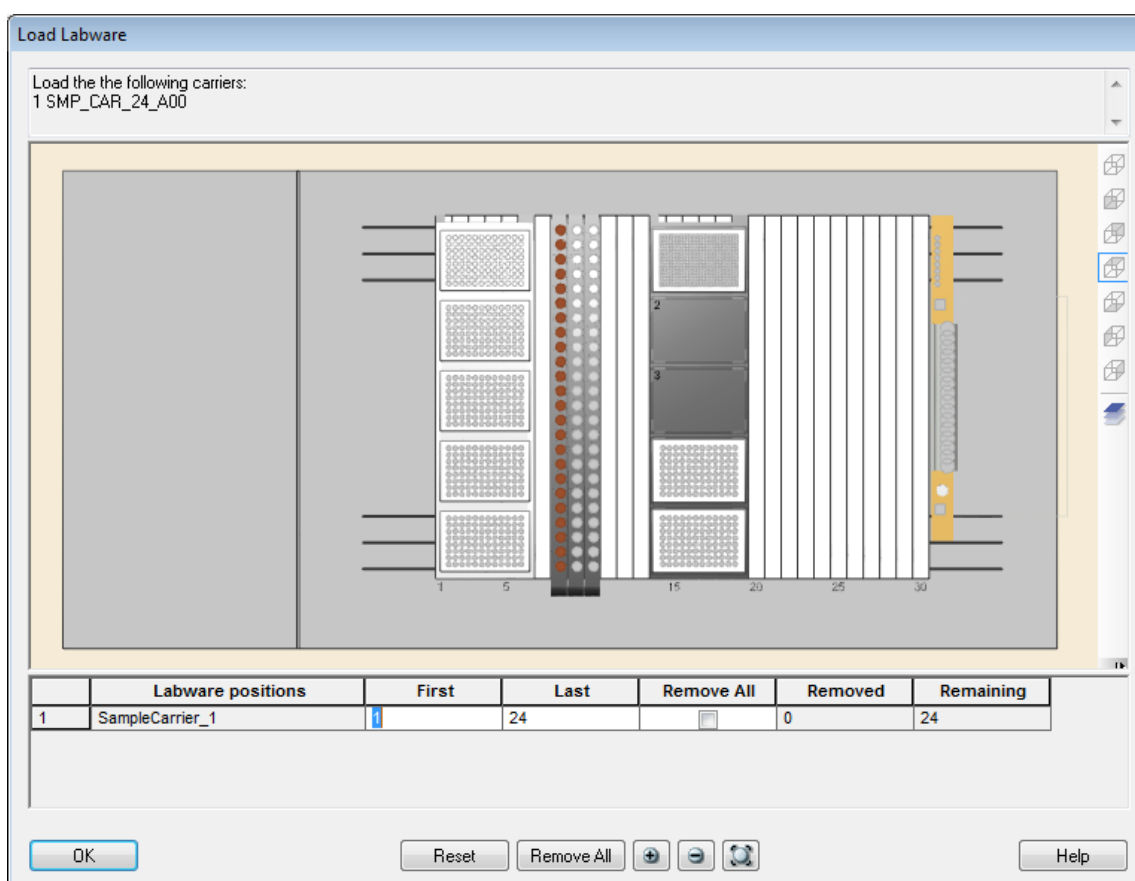

Loading Dialog

8. Enter the number of samples, tips or wells for this run, delete items graphically from the highlighted positions on the deck (first select the appropriate item in the table), or accept the default.
9. Generally, whenever the system finds a 'Load Carrier' command in the method, the operator is requested to place the carrier holding the appropriate labware onto the Autoload tray. The correct position is highlighted by blinking LED's.



ATTENTION

It is important to ensure that adequate amounts of the correct liquids are placed in the correctly labeled containers.

When pouring reagents into the reagent containers, ensure that there is no foam on the surface of the liquid.

Do not overfill reagent containers: fill approximately 10mm below the top of the container.

Always use the proper labware (tips, microplates, tubes, etc.) corresponding to the definitions of the method's layout.

Position microplates correctly such that well #A1 is placed according to the deck layout.

Handle any 1-track carrier (such as a sample carrier) with particular care, as this type of carrier can fall over and cause injury or contamination. Position it onto the Autoload tray (see figure below), or place several carriers together to minimize this risk.

10. Insert the carriers into the tracks between the front and rear slide blocks of the Autoload tray until they touch the stop hooks on the far side of the tray.

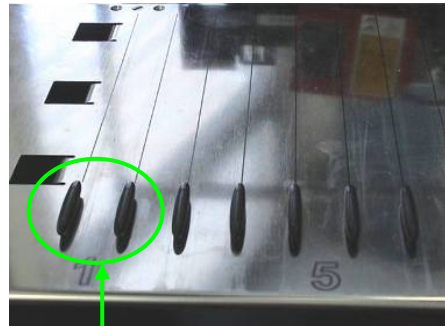
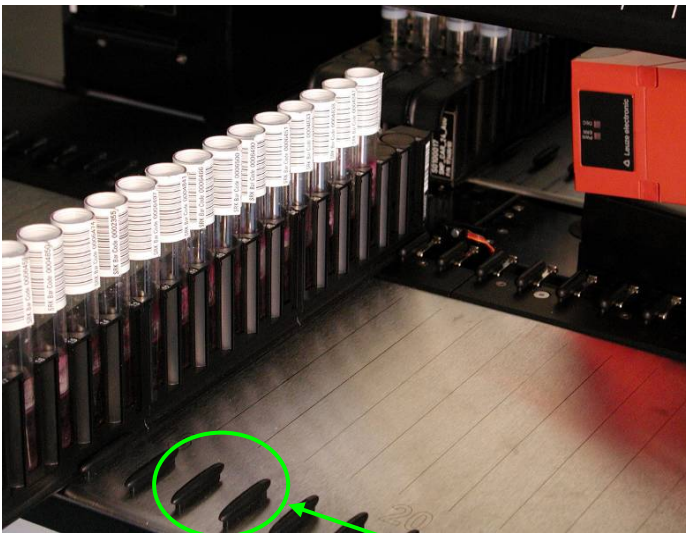

Slide Blocks for Carriers



Stop Hooks for Carriers



ATTENTION

Make sure the carriers are inserted completely as far as they will go on the loading tray.

11. Click **[OK]** in the dialog. The carriers are loaded onto the deck automatically by the 'Load Carrier' command in the method. During loading, the barcodes of the carriers and labware are read and stored in a file.

or

Alternatively, load the carriers onto the defined positions of the Autoload tray before starting the method. Loading and barcode reading will then be performed without operator input. Still the following dialog is displayed:

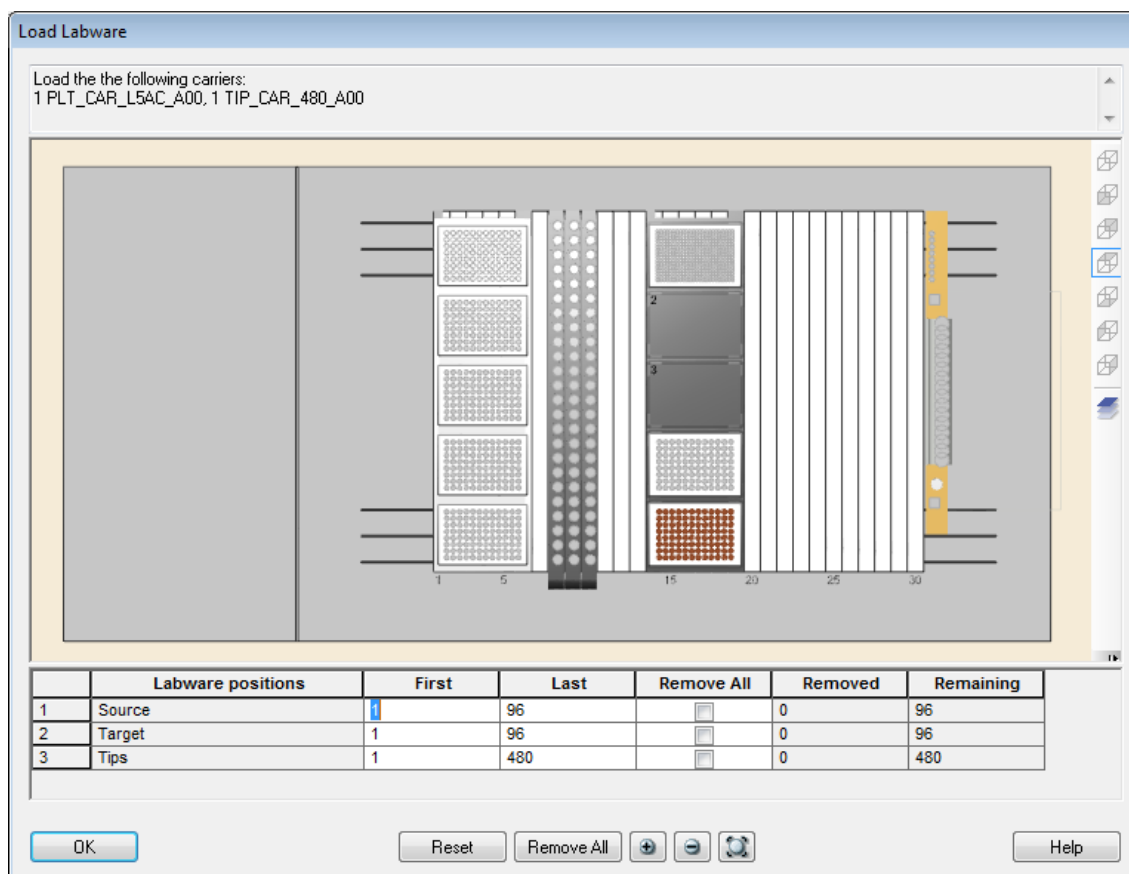

12. Enter the number of wells (e.g. on the source plate for this run), delete wells graphically from the sequence or accept the default (copy the entire plate).

For a Manual Load System only:

13. Load the deck with the carriers mentioned in the upper part of the dialog box (the two plate carriers and two tip carriers). Don't forget to place labware onto the correct positions.

For an Autoload System only:

14. Whenever the system finds a "Load Carrier" command in the method, the user is requested to feed the carrier holding the appropriate labware onto the Autoload tray. The correct position is highlighted by LED's on the instrument. Alternatively, all carriers can be placed directly in their correct positions on the Autoload tray.
15. Click **[OK]** in the dialog box to start loading.

For a Manual Load System only:

16. Click **[OK]** in the dialog. Unload all the carriers manually. The unloading will be checked by the system.

For an Autoload System only:

17. Click **[OK]** in the dialog. The carriers are unloaded to the Autoload tray.

18. The method is now finished. Method completion information is visible in the "Trace View" window.

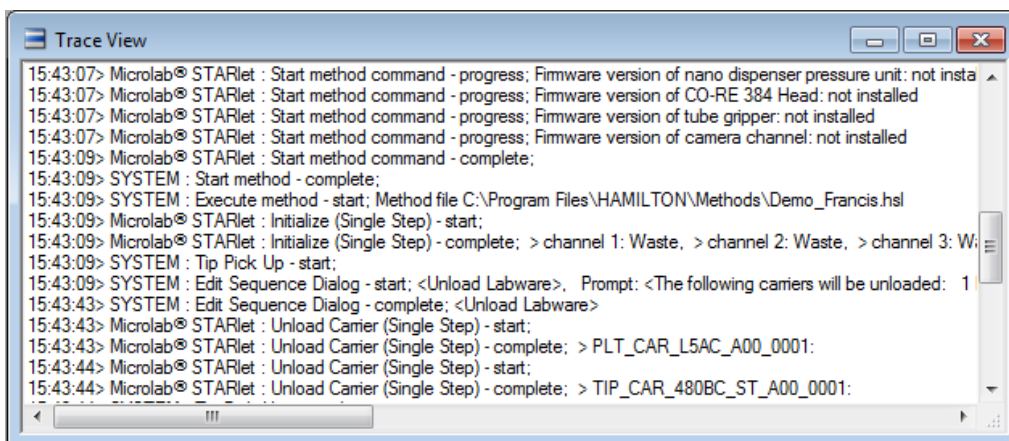

For the iSWAP only:

19. Usually, at the first run of a day, the iSWAP needs to be initialized. There is also a possibility that there is still a plate in the gripper of the iSWAP. In case a plate is caught by the gripper, it can be safely removed.

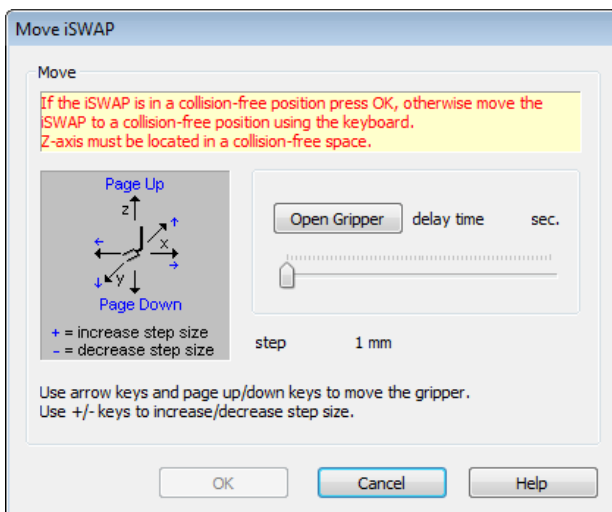

3.1.1 Method Trace File

Every run creates a separate method trace file. The method trace file is stored under “{method namex32x}.trc” within the “...\LogFiles” directory. Each method trace contains the method name, and a unique number consisting of 32 hexadecimal digits, here represented by “x32x”, within the file name. The method traces are not overwritten or appended.

Name	Größe	Typ	Geändert am
ComTrace_Simulator20070108.trc	83 KB	TRC-Datei	08.01.2007 11:24
Demo_a47818bacecf48ccb1d850084b0d6901_Trace.trc	6 KB	TRC-Datei	08.01.2007 11:24
Demo_Barcodes.txt	1 KB	Textdokument	08.01.2007 11:24

3.1.2 Communication Trace File

The communication trace file is created every day or when the instrument is switched on. A communication trace file is also generated under the “communication name” (Simulator, HxUSBComm) and current date, where the communication of each run of the method will be appended. If barcode information is generated, its data will be stored in a file labeled with the method’s name followed by “*_Barcodes.txt”.



NOTE

From time to time all unused method traces and com traces should be deleted from the hard disk.

3.1.3 Single Step Mode

The method can be tested using Single Steps. It is always possible to start a run in Single Step mode (like TipPickUp, Aspirate, Dispense, etc.).

1. Click the **[Single Step]** button, to start the method in single step mode.

or

Pause a method at any time by clicking on the **[Pause]** button on the Run Control Window. The step currently running will be terminated, and the following message box appears:

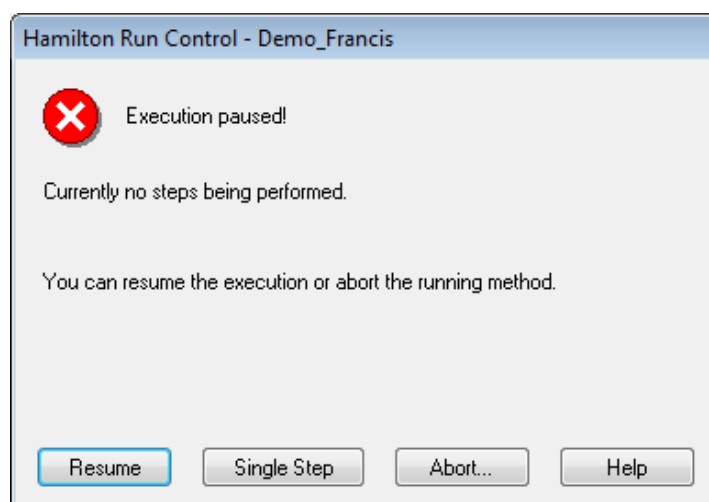

2. Click anywhere in the pause dialog to stop the beeping.
During the pause, it is possible to open the front cover of the instrument.
3. Before continuing the method, make sure the cover is closed again.
4. Resume the paused method by clicking **[Single Step]**
or
Resume method execution by clicking **[Continue]**, to run the method without further breaks
or
Abort method execution by clicking **[Abort...]**. It will be prompted to confirm the abort.



NOTE

*An abort may cause loss of data.
Aborted methods cannot be restarted again, unless explicitly programmed.
A fast abort can always be done by opening the front cover of the ML STAR instrument during a run.
A method can be aborted even if **[Pause]** is active.
To prevent loss of data or bad pipetting results, **[Pause]** will finish the proceeding step and then stops.*

3.1.4 Run Simulations

It is also possible to run a simulation instead of the actual run. It is recommended to always simulate a newly created method first, before running it on the instrument. The run simulation is switched on in the menu “Settings”:

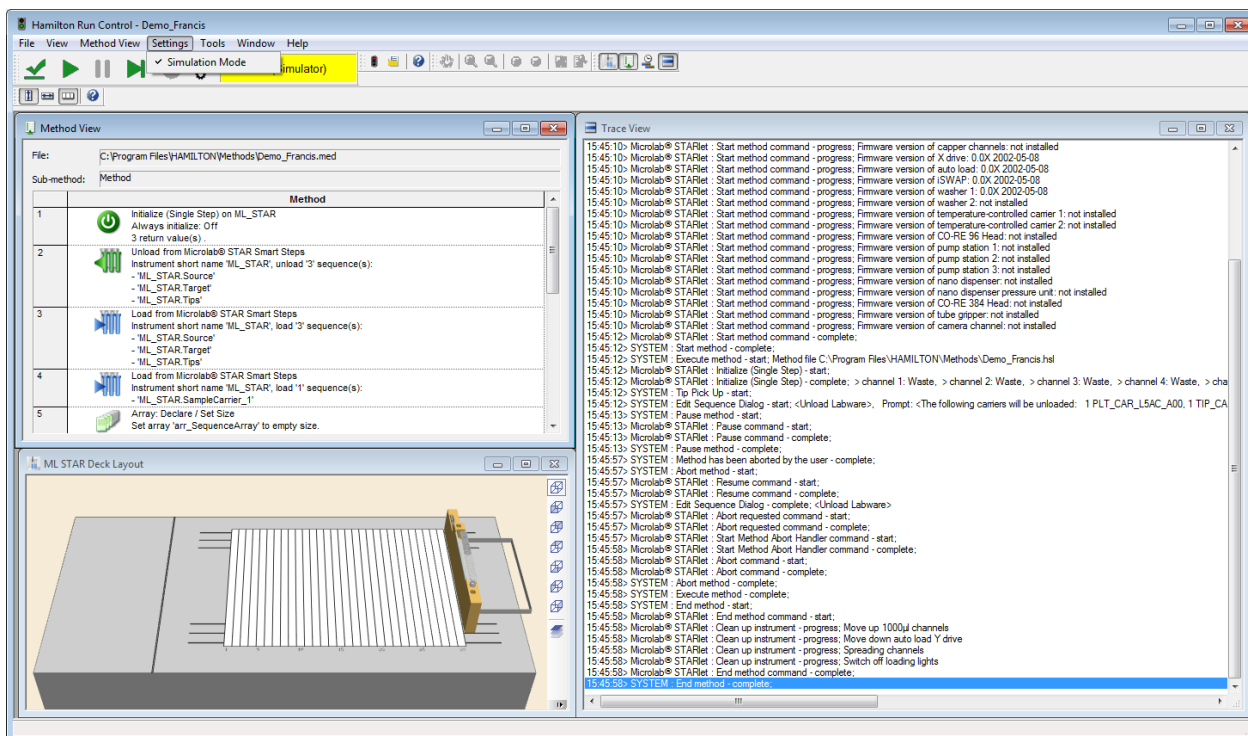

1. Enable the simulation by clicking to **[Settings / Simulation Mode]**.
2. The run simulators check the consistency of each (single) step of the system, together with minimum aspiration and dispense volume management.
3. The speed for simulations is adjustable. If the default speed (at maximum is best guess under real runs) is too fast the speed can be reduced by the simulator delay via the configuration editor. Refer to the [Microlab STAR Programmer's Manual](#).

3.2 Retrieving Objects

3.2.1 Retrieving Objects from the iSWAP

Usually, at the first run of a day, the iSWAP needs to be initialized. There is a possibility that there is still an object (e.g. plate) in the gripper of the iSWAP. In case an object is caught by the gripper, it can be removed safely using the "Move iSWAP" dialog.

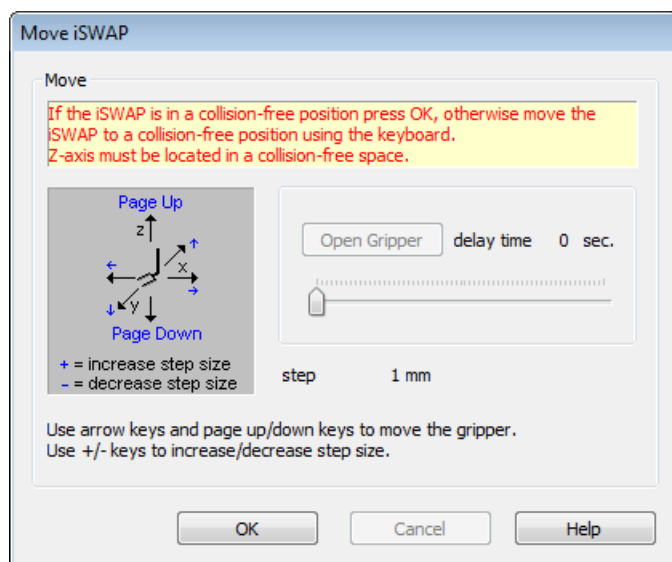

Removing a gripped object:

1. Use the "+"/"-" keys to define the distance (e.g. 10mm) the gripper shall be opened to release the object.
2. Define a "delay time" moving the pointer of the slide bar.
3. Calculate the time (e.g. 5 seconds) you will require to walk from the PC to the instrument and place your hand underneath the object.
4. Open up the front cover of the ML STAR instrument and check if you can retrieve the object.
5. If you cannot access the object move the X-Arm using the arrow keys and page up / page down keys.



ATTENTION

Make sure the selected step size and moving direction will not crash the iSWAP. Always wear gloves, eye protection and lab coat for manipulations inside the instrument.



ATTENTION

When using the iSWAP to transport plates, a plate carrier must be used as listed in this manual (see [Section 8.1 Ordering Information](#)). If other carriers are used, make sure that the plate position is verified.

6. If there is enough time and space to hold the object and the gripper parameters are set, click the **[Open Gripper]** Button.
7. If the iSWAP cannot move up to the traveling height without a collision (e.g. shelving position where the iSWAP would collide with the shelf above it), it must be guided to a safe area using the keyboard (arrow keys, page up / page down keys, + / - keys).



ATTENTION

Make sure the selected step size and moving direction will not crash the iSWAP.

8. If the iSWAP is ready for initialization, click the **[OK]** Button.

3.2.2 Retrieving objects from the Tube Twister Channel

Usually, at the first run of a day, the Tube Twister Channels need to be initialized. There is a possibility of objects (e.g. tube) still gripped by one or more Tube Twister Channels.

The situation may appear when a run was aborted either automatically by the system (in case of irregularities detected by the instrument) or when a manual abort was triggered by the operator.



ATTENTION

Retrieving objects from the Tube Twister Channel requires completing steps within specified time frames. Read and understand the complete instructions given in this chapter before retrieving objects.



ATTENTION

Always wear gloves, eye protection and lab coat for manipulations inside the instrument.

1. Depending on the status of the instrument, the following dialog may first appear.

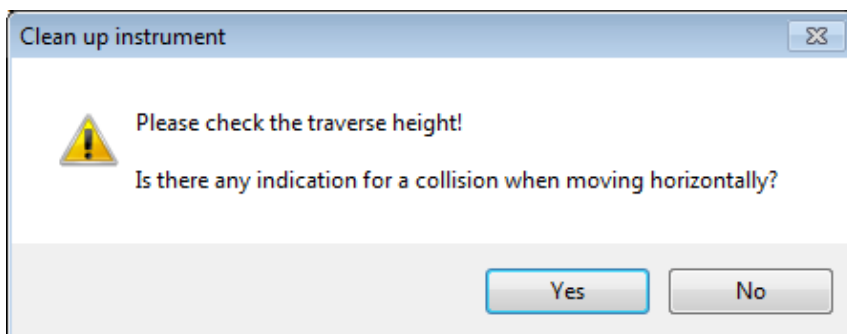

Check for the situation of the gripped object.

2. If for any reason, the Tube Twister Channel cannot move horizontally, press **[Yes]** and recover from the situation manually after shutdown of the instrument.
3. If there is no indication for a collision, press **[No]**.
4. In case one or more objects are caught by the grippers, it can now be removed safely using the **Tube Twister Channel – Labware Exists** Dialog.

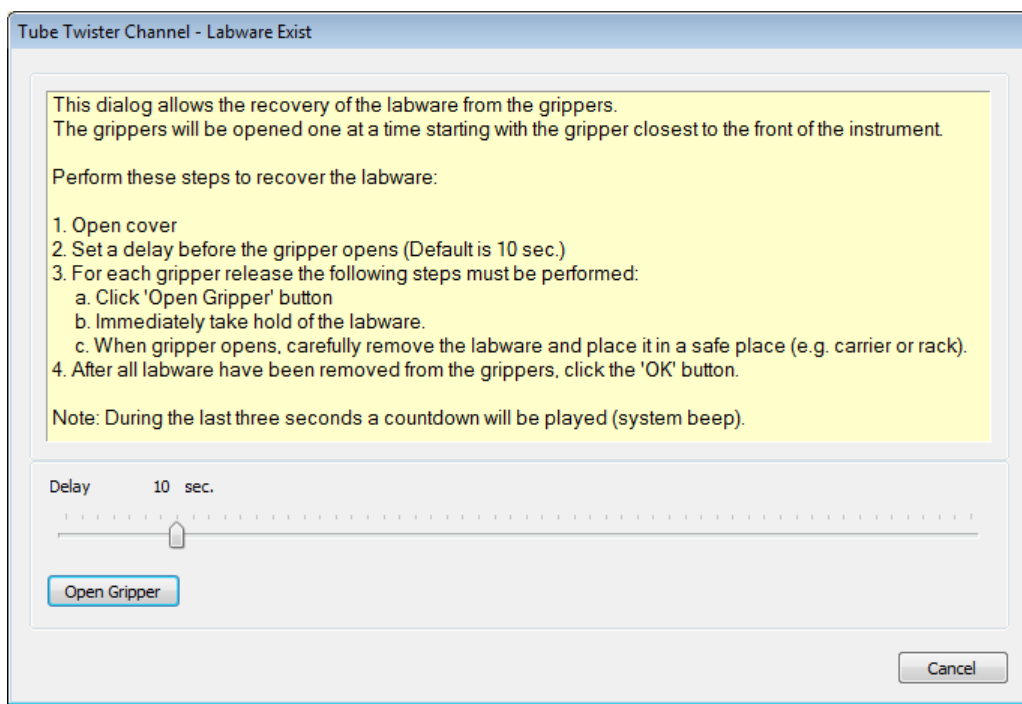
**Removing a gripped object:**

5. Remove any carrier from the Autoload Tray.
6. Open the front cover of the ML STAR Instrument and check if you can retrieve the gripped objects.
7. If you cannot access the object, do not open the gripper. Click **OK** and handle the situation manually after shutdown of the instrument.
8. If you can access the object, calculate the time (e.g. 10 seconds) you will require to walk from the PC to the instrument and to place your hand underneath the gripped object. Use the slider to set the required "**Delay Time**".

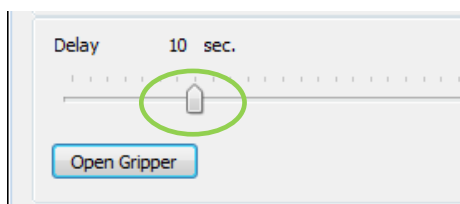

9. If there is adequate time set and space to hold the gripped objects click the **[Open Gripper]** Button. Immediately take hold of the object.



10. For the next object, click the **[Open Gripper]** Button. Immediately take hold of the object.
11. Repeat the step until all objects are released from the grippers.
12. Remove the objects from the deck.
13. Close the front cover.
14. Click the **[OK]** Button to proceed.

3.2.3 Retrieving objects from the Decapper Module

Usually, at the first run of a day, the Decapper Module needs to be initialized. There is a possibility of objects (tubes) still sitting in one or more Decapper Stations.

The situation may appear when a run was aborted either automatically by the system (in case of irregularities detected by the instrument) or when a manual abort was triggered by the operator.



ATTENTION

Retrieving objects from the Decapper Modules requires special attention. Always use the specific pliers supplied with the Decapper Module to avoid pushing down the vial into the Decapper Module and damaging the locking springs. Take special care not to spill liquid into the Decapper Module.



ATTENTION

Always wear gloves, eye protection and lab coat for manipulations inside the instrument.

In case one or more objects are sticking in the Decapper, the following dialog will be displayed.

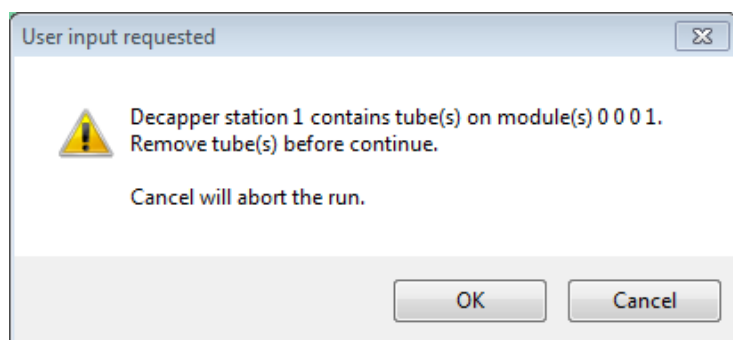

Removing an object:

1. Remove any carrier from the Autoload Tray.
2. Open the front cover of the ML STAR instrument.
3. Insert the pliers into the open tube or into the depression of its cap and grip the object.



4. Carefully pull out the tube of the Decapper Station. Avoid spilling liquid. Take care not to deform the locking spring within the Decapper Station.
5. Close the front cover.
6. If all Decapper Stations are checked and clear, click the **[OK]** button to proceed.

3.3 Error Handling

3.3.1 Run-Time Error Handling

Before using the run time error handling, several types of problems causing errors have to be solved first. Among these are:

- Syntax errors when programming in HSL (e.g. forgotten “;”)
- Logical errors (e.g. “tip eject” before “pick-up”, or “asp 20 μ l”, “disp 100 μ l”)
- Semantic errors (e.g. wrong pipetting pattern)
- Method/deck interaction errors (e.g. dispense 100 μ l into the first well of a 1536-well MTP)
- Liquid handling/application errors (e.g. droplets, foam, non-pipetted wells)
- User-related errors (e.g. wrong deck loading)

These problems *cannot* be handled by any run time error handling. They have to be solved in advance, while or after the programming. Refer to the [Microlab STAR Programmers Manual](#).

Problems that *can* be handled in run time are:

- Not enough liquid
- Liquid level not found (if it occurs as an exception)
- No tip picked up
- Clot detected
- Barcode unreadable (if it occurs as an exception)
- Execution error (channel no. 1 has an error (e.g. not enough liquid), then channel numbers 2-8 have an execution error because they have been stopped before completion of the step)



NOTE

In principle, each channel may have one or more different types of errors at a time.

If all channels have the same error at the same time, a collective recovery can be made.

3.3.2 Run-Time Error Handling Examples

We now focus on some important examples. A detailed description is available in the VENUS Help Function. Click on **[Error Settings]** within the single step dialogs of the ML STAR -specific commands and select **[Help]**.

3.3.2.1 Barcode Reading Error

1. In the case of an error, the process can be continued using the error handling procedure. If, for example, a barcode of a carrier cannot be read, a dialog window opens up:

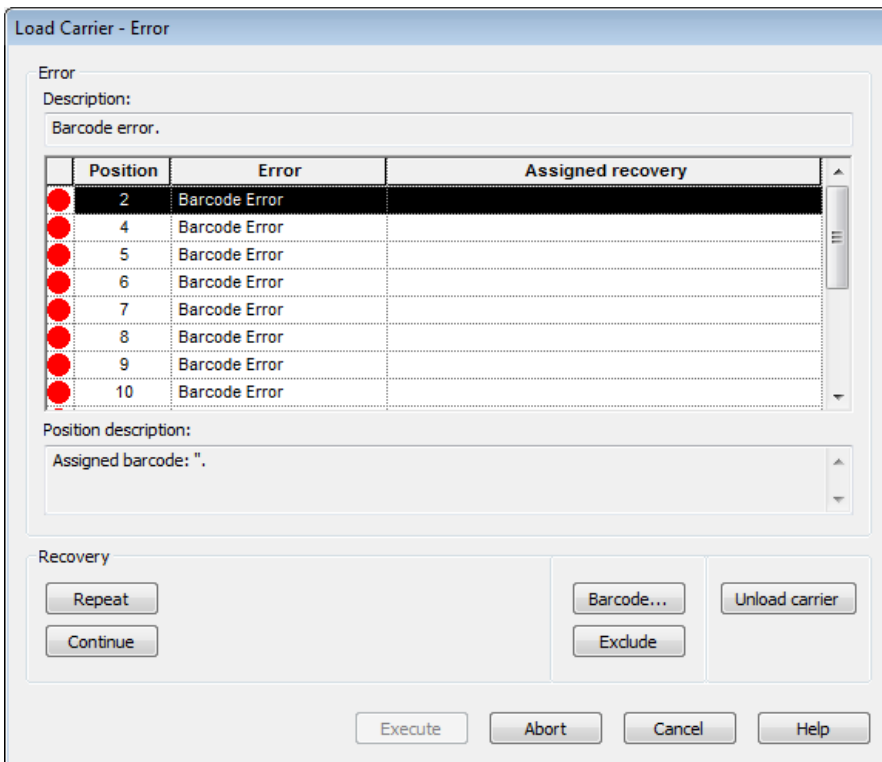

2. The error recovery can be programmed to:

- **Continue** Ignore the error message (here, failure of barcode reading)
[Continue] makes no sense in the case of a barcode reading error - at least a manual entry has to be made so that barcode data exists for further processing.
- **Repeat** Try to read the barcode once again
Often a repetition of reading will solve the problem because the reading speed is reduced then. The selected action is displayed in the field **[Assigned recovery]**.
- **Barcode...** Enter the barcode manually
Clicking **[Barcode]** opens an entry dialog box where a barcode can be entered (no entry is also allowed).

3. Assign a recovery option. The **[Execute]** button becomes active.

4. Click on **[Execute]**. The instrument proceeds with the selected recovery option.

3.3.2.2 Pipetting Error

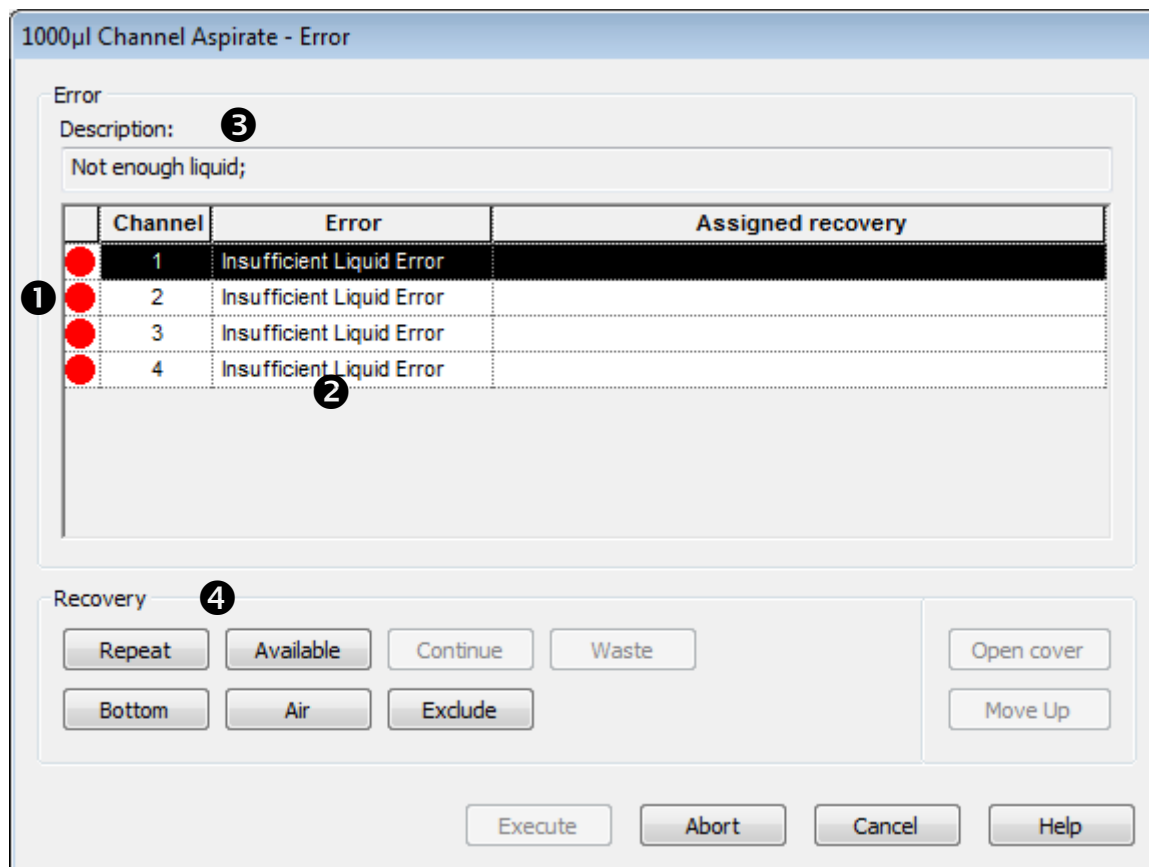

1. If an error occurs with the pipetting channels, a dialog shows its error state and its recovery options for every single channel (Different channels can have different errors).

For example, in case of an LLD error, such as no liquid in the container while aspirating, a window similar to the following is displayed:



2. All pipetting channels which produced an error are listed with a red dot on the left **1**. A short error description **2** is given. A detailed error description is shown at the top text field **3** labeled

“Description:” for the selected pipetting channel. There may be different errors which lead to the same short error description.

3. The **[Recovery]**  frame buttons offer several possible actions to solve the problem:
 - **[Repeat]:** Executes the command which caused the error once again
 - **[Available]:** Aspirates the available volume from the source and fills up the missing volume with air
 - **[Continue]:** Continues as if no error was recognized
 - **[Waste]:** Means that the erroneous tip is ejected to the waste and the channel is excluded
 - **[Bottom]:** Activates the channel to move down to the bottom of the container, and the available volume is aspirated without LLD
 - **[Air]:** Means air is pipetted instead of liquid and the method will continue
 - **[Exclude]:** Allows disabling any further action on the error-affected pipetting channel
 - **[Move Up]:** This is not a real error recovery procedure, but useful (e.g. to manually remove a clot). This causes the following actions (this action can be repeated):
 - moves the barcode reader of the Autoload (if present) to the very right
 - moves the selected pipetting channel up by 10mm
 - **[Open Cover / Close Cover]:** this button does not start any error recovery actions either, but triggers the following actions:
 - **[Open Cover]:** enables opening the front cover during error recovery
 - **[Close Cover]:** enables closing the front cover before executing error recovery
4. An error recovery needs to be assigned for every error. Selecting a pipetting channel followed by any possible recovery procedure assigns the selected recovery procedure to all error-affected pipetting channels with the same error.
5. If any recovery procedure is assigned to a pipetting channel (even one which is not desired to be assigned), the dot  in the first column (see picture above) changes color to green.
6. Some recovery buttons are disabled, to prevent further faulty steps, (e.g. an error-affected aspiration step cannot be “Continued”), to prevent any later dispense with insufficient volume.
7. When the last faulty pipetting channel is assigned to a recovery procedure, the **[Execute]** button becomes active and the system can proceed.
8. In any case, the method can be aborted without further recovery options.

3.3.2.3 Walk-Away (Predefined) Error Handling

1. The programmer can define a walk-away error handling which uses predefined default settings for different error situations. These settings can be customized for single steps and easy steps only. For Smart Steps, the error recovery is fixed.
2. For every instrument-specific single step of the method, an individual error recovery can be defined. The following can be configured:
 - The appearance of the error recovery dialogs (which buttons are available)
 - A timeout, after which the default recovery is carried out (the dialog automatically closes down)
 - The default procedure (what should be executed if the timeout runs out)
 - Which error is flagged in the trace file
3. For this purpose, every instrument-specific Single Step and Easy Step has an **[Error Settings]** button. To deal with the subject of error handling consult the [Microlab STAR Programmer's Manual](#).

4. Maintenance

The ML STAR operator is instructed to maintain the instrument on a regular basis; this maintenance consists largely of surface cleaning and does not require opening up the instrument (i.e. any unscrewing, removing deck, covers, etc.).

The operator is responsible for changing consumable parts (disposable tips, needles, waste Bag, etc.). The Hamilton trained field service engineer generally changes spare parts (PCBs, cables, channels, etc.).

Periodic maintenance routines need to be run in order to ensure safe and reliable operation of the ML STAR instrument and the accessories. The Hamilton trained field service engineer will need to service (perform preventive maintenance) the instrument at least twice a year. In addition, the Hamilton trained field service engineer may be called to repair a damaged component of the instrument or to resolve a functional problem, which the user cannot resolve himself (such as adjusting and calibrating the pipetting channels).



ATTENTION

When parts and accessories have application engineering (APE) modified parts adapted for a specific application, the original parts must be attached/used when performing adjustments/calibrations with the macro programs. After the adjustments/calibrations have been completed, re-install the modified parts.

Depending on how the VENUS Software is configured (maintenance configuration settings), the maintenance routines might be mandatory. If so defined – until they are completed, the user is reminded by a warning.

4.1 STARwatch Advanced Service



STARwatch is a pro-active service which increases the uptime of ML STAR instruments.

STARwatch continuously monitors the condition of the dedicated instrument. The captured data is automatically analyzed, and when a critical pattern is recognized, the service organization is immediately informed to provide a proactive intervention.

STARwatch intended use is primarily for high throughput laboratories where a certain consistency of daily routine use is given and where a short down time is critical.

STARwatch is available in addition during the warranty period and later in combination with a service contract. STARwatch has to be obtained on a yearly basis. Its license is valid for one year.

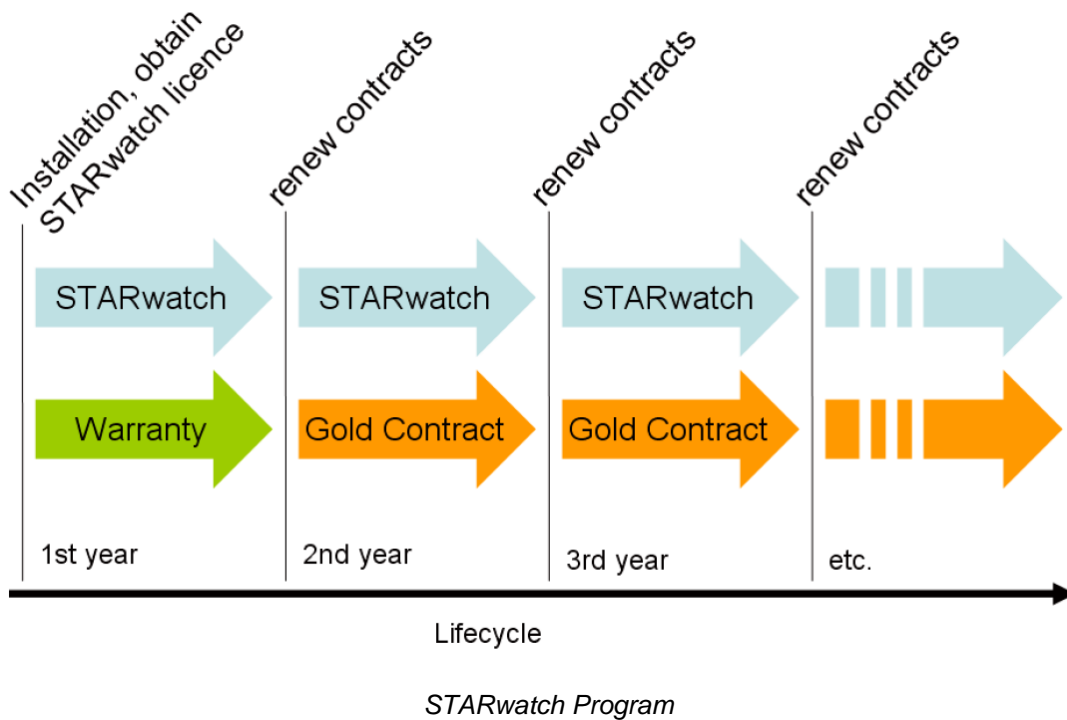

Refer to our [Technical Note “STARwatch Condition Monitoring System”](http://www.hamiltonrobotics.com), available on our website www.hamiltonrobotics.com.

4.2 Maintenance Intervals

We recommend maintaining the instrument at the following intervals:

- Daily Recommended before the instrument is shut-down at the end of the day
- Weekly Recommended at the end of the week before the instrument is shut-down
- Half-Yearly Recommended Preventive Maintenance carried out by a Hamilton trained field service engineer



NOTE

If the operator decides not to run either daily or weekly maintenance before shut-down of the instrument, these routines must be implemented at the next run start.

If any parts of the instrument, carriers or racks have become contaminated, the weekly maintenance procedure must be performed.

4.3 If Maintenance Fails

If an error is encountered during a maintenance procedure, try to rectify the problem and re-start the maintenance procedure. If this should fail, call your local Hamilton trained field service engineer.

4.4 Preventative Maintenance

Preventive maintenance including verification should be carried out at regular intervals by a Hamilton trained field service engineer. A service agreement ensures regular maintenance and verification for a specified period of time. Hamilton recommends that maintenance and verification take place twice a year.

4.5 Materials Required

- Disposable latex gloves
- Protective glasses
- Lab coat
- Paper towels
- Lint-free cloths or Q-tips
- Set of 8 teaching needles - please refer to [Section 8.2.3 Teaching Needles](#)
- Ethanol (70%)
- De-ionized water
- Microlab Detergent & Disinfectant Kit (P/N 281242) (contains Deconex[®] 61 DR) - please refer to [Section 8.2.14 Liquids for Maintenance](#) or Microcide SQ (only available in the USA).
- Microlab Disinfectant Spray Kit (P/N 281243) (contains Deconex[®] SOLARSEPT) - please refer to [Section 8.2.14 Liquids for Maintenance](#)
- Microlab Disinfectant STARTER Kit (P/N 281245) (contains Deconex[®] 61 DR and Deconex[®] SOLARSEPT) - please refer to [Section 8.2.14 Liquids for Maintenance](#)



ATTENTION

Use cleaning, disinfecting and decontaminating fluids in accordance with manufacturer's instructions. Do not use disinfecting materials which contain hypochlorite (Javel water, Chlorox) or bleaching fluids.

Prepare disinfectant fluids according to their labeling.

4.6 Instrument Maintenance Procedures

The operator will be guided by the VENUS Software through the regularly scheduled maintenance procedures.

Depending on the maintenance configuration settings (*optional*, *warning* or *mandatory*), the instrument will display messages when starting up the instrument:

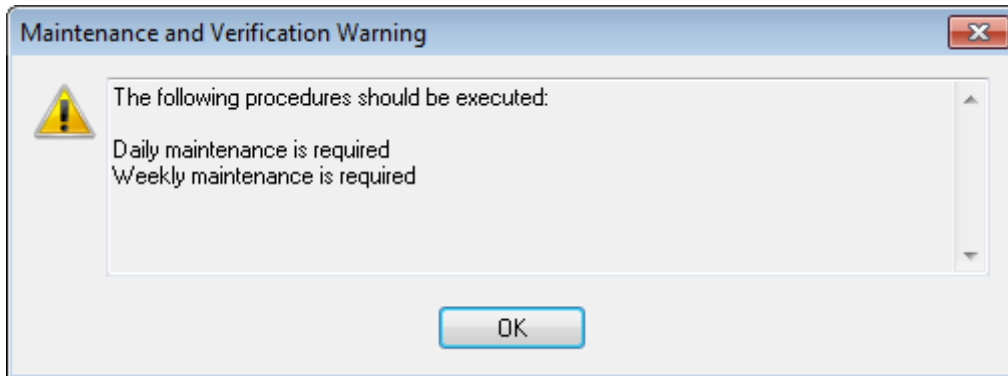

Displayed warning if maintenance is needed, configuration setting = warning

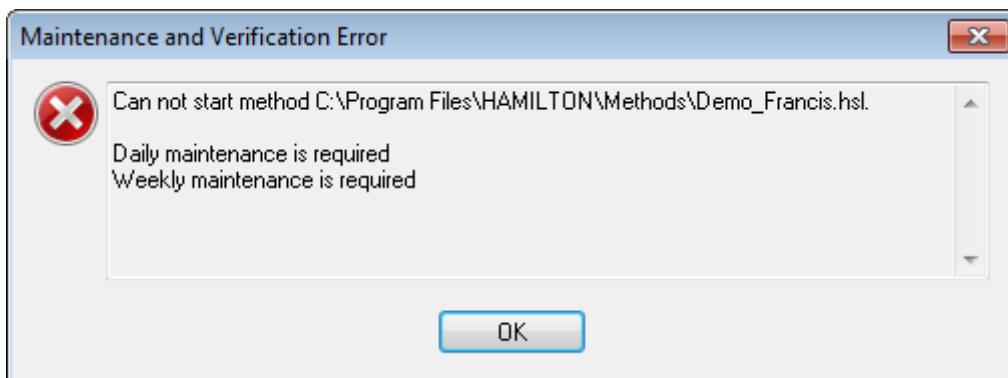

Displayed error if maintenance is needed, configuration setting = mandatory



ATTENTION

Always wear disposable gloves during maintenance.

Do not clean the instrument in the vicinity of unshielded flames or devices which could create sparks. Do not use hot air blowers to dry the instrument. The liquids used for cleaning may be flammable.

Maintenance work on the iSWAP is not permitted, because adjustment may be lost. Clean the iSWAP only where necessary after spillage and be careful of sharp edges on the gripper jaws.

Any regulations for waste disposal specific for the country of operation must be taken into account and observed.

Routine Completion:

A maintenance routine is completed once the procedure has been fully implemented and the results are within specifications.

Aborting Maintenance Procedures:

Aborting a maintenance procedure will lead to a 'failed' status, and maintenance will need to be started again.

4.6.1 Daily Maintenance

Daily maintenance is configuration dependent. The following tasks are examples belonging to the daily maintenance:

- Check if the deck is clean
- Empty the tip waste
- Check the tightness of the 5ml/1000µl pipetting channels
- Verify the cLLD functions properly (5ml/1000µl pipetting channels)
- Perform the rinse procedure of the wash station(s)
- Check if the CVS vacuum system is working properly

To execute the Daily Maintenance procedure:

1. Double-click the **Microlab STAR Maintenance** Icon on the desktop:



2. In the **Hamilton Maintenance and Verification Run** Main Window, the process status information view lists all maintenance and verification processes for the connected/selected instrument.

Here the operator can start the necessary commands to perform all maintenance-related routines.

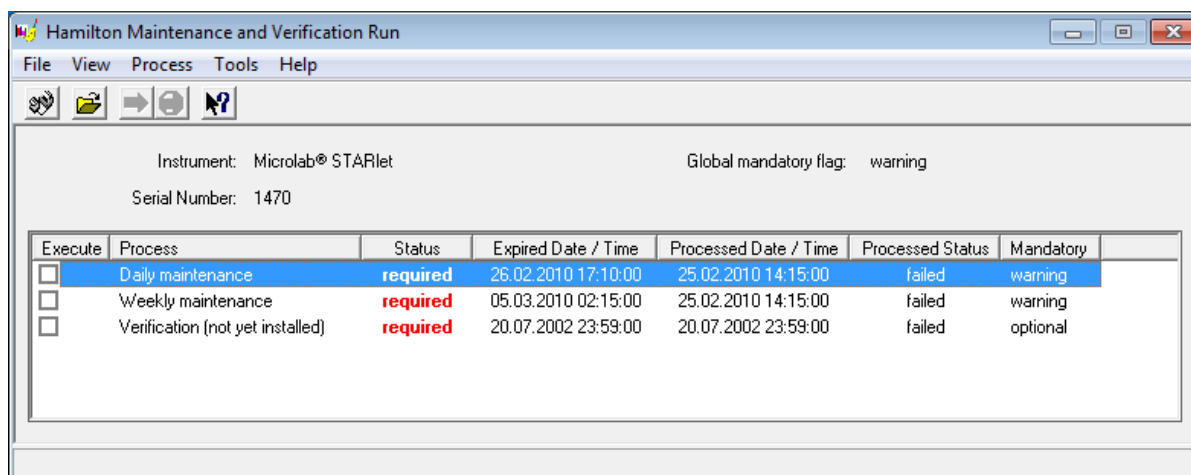

Hamilton Maintenance and Verification Run Main Window

3. Select the desired maintenance routine by clicking the specific check box and by pressing the **[Run Process]**  button. The VENUS Software will then issue on-screen instructions detailing all procedures required to perform the selected maintenance routine.

4. After instrument initialization, the operator will be asked to execute the daily maintenance:

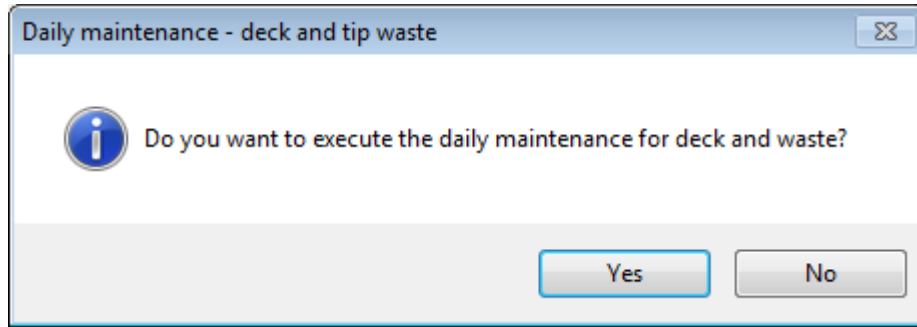

5. After clicking **[Yes]**, the daily maintenance procedure will be started. Pressing **[No]** will abort the procedure.
6. The front cover (the hinged acrylic glass window that shields the instrument in front) can be opened for user intervention.
7. Once the maintenance procedure has been started, the pipetting arm moves to the left side. The operator now has access to the deck to check if cleaning is needed or not:
 - If the deck is clean, continue with the daily maintenance
 - If the deck needs to be cleaned, the daily maintenance can be interrupted. Instead of the daily maintenance, perform the weekly maintenance
8. Continuing the daily maintenance procedure will lead the user to the next maintenance task. The tip waste needs to be emptied. Dispose of it with the rest of the laboratory's contaminated waste.



ATTENTION

The tip waste is always to be regarded as contaminated.

9. For the next steps the teaching needles are required.

Teaching Needles for
5ml Pipetting Channels

Teaching Needles for
1000µl Pipetting Channels



Location of Teaching Needles for Maintenance

10. The procedure continues with the tightness check of the pipetting channels. The pipetting arm will travel to the right hand side to pick up the teaching needles.
Two checks are done with the pipetting channels, the over-pressure and the under-pressure check.
11. For the capacitive liquid level detection (cLLD) check, the needles are picked-up again. Each pipetting channel is checked one at a time, for proper cLLD function.
12. If there is a CVS installed, a rinse procedure is started. Refer to [Section 4.13 Crystal Vacuum System](#).
13. If there is a needle wash station installed, a rinse procedure is started. Refer to [Section 4.10 CR Needle Wash Station](#).
14. When the daily maintenance is completed, the “Daily maintenance execute successfully completed” screen is displayed.

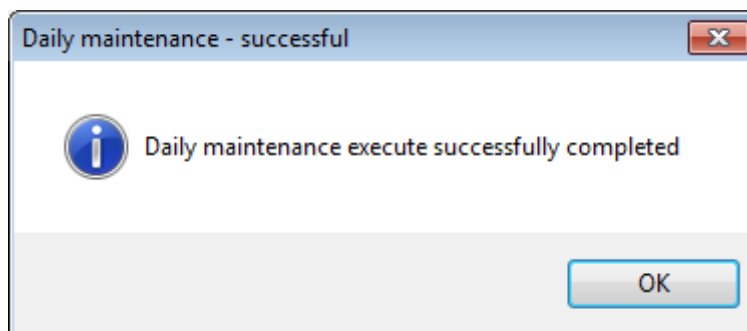

15. The daily maintenance process status is saved on the instrument and a report file is created. Refer to [Section 4.7 Printing a Report](#).



NOTE

If any parts of the instrument, carriers or racks have become contaminated, the weekly maintenance procedure must be performed.

4.6.2 Weekly Maintenance

Weekly maintenance is configuration dependent. The following tasks are examples belonging to the weekly maintenance:

- Clean the deck and carriers
- Check the condition of all carriers
- Empty and clean the tip waste
- Check the tightness of the 5ml/1000µl-pipetting channels
- Verify the cLLD functions properly (5ml/1000µl-pipetting channels)
- Perform the maintenance procedures for the wash station(s)
- Clean of the pipetting head: stop disk, O-ring, tip eject sleeve
- Clean of the covers, Autoload protection ribbon
- Check if the CVS vacuum is working properly

To execute the Weekly Maintenance procedure:

1. Double-click the **Microlab STAR Maintenance** Icon on the desktop:



2. In the **Hamilton Maintenance and Verification Run** Main Window, the process status information view lists all maintenance and verification processes for the connected/selected instrument.

Here the operator can start the necessary commands to perform all maintenance-related routines.

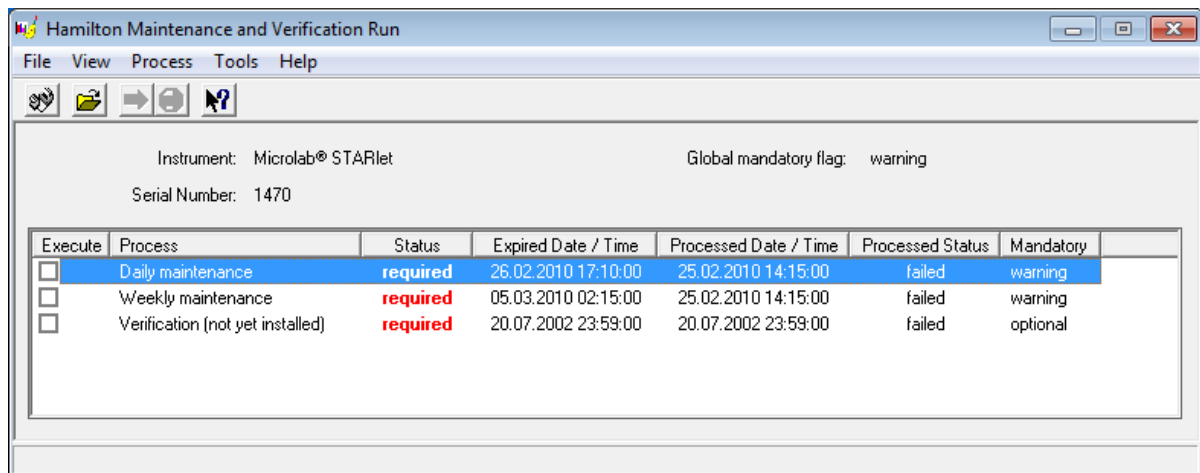

Hamilton Maintenance and Verification Run Main Window

3. Select the desired maintenance routine by clicking the specific check box and by pressing the **[Run Process]**  Button. The VENUS Software will then issue on-screen instructions detailing all procedures required to perform the selected maintenance routine.
4. After initialization of the instrument, the operator will be asked to execute the weekly maintenance:

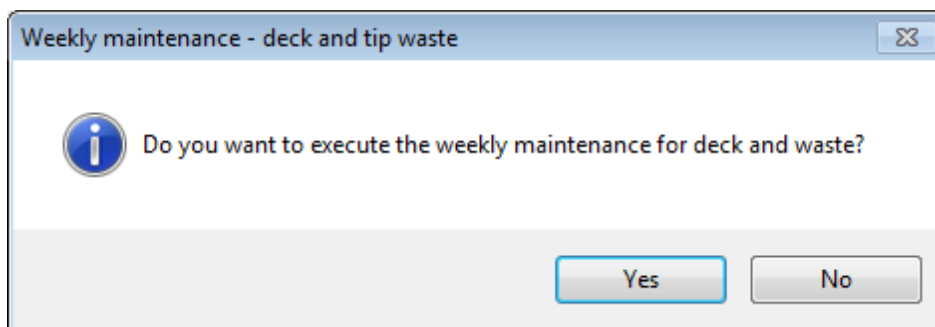

5. When the instrument is initialized, the weekly maintenance program advises the user to unload the deck manually. If the Autoload option is available, this step is carried out automatically.

6. Clean all carriers with Deconex[®] SOLARSEPT spray and leave them to dry. If they are heavily soiled, soak them afterwards in a solution of Deconex[®] 61 DR cleaning liquid (refer to the product data sheet for further information).

Examine each carrier for scratches on the barcode and any signs of damage. If damage is apparent, replace with new carriers.

7. Continuation of the weekly maintenance program will advise the Autoload (if configured) to move to the right hand side of the instrument.
8. Open the front cover and wipe the deck with a cloth saturated with Deconex[®] SOLARSEPT. The slide blocks in particular must be checked for cleanliness. Close the front cover.



ATTENTION

Do not spray directly at the Autoload or at electrical boards or connectors.

9. The next step of the maintenance procedure will advise the Autoload (if configured) to move to the left hand side of the instrument. The tip waste needs to be emptied and cleaned. Dispose of it with the rest of the laboratory's contaminated waste.



ATTENTION

The tip waste, the tip eject plate, and the plastic bag are always to be regarded as contaminated.

10. Remove the tip eject plate of the tip waste station and clean it: spray Deconex[®] SOLARSEPT directly onto the surface and wipe. Remove the frame that holds the plastic bag in place, and discard the plastic bag in the laboratory's contaminated waste. Pull a new plastic bag over the frame and re-attach it. Put the clean tip eject plate back in place.

Remove and clean the teaching needles: spray Deconex[®] SOLARSEPT directly onto the surface and wipe. Put the clean and dry teaching needles back in place.

11. If the Autoload option is configured: to prevent unreliable barcode reading, check the laser scanner window of the barcode reader and clean it with a lint-free cloth or Q-tips lightly soaked in Ethanol (70%).



ATTENTION

The laser scanner window must be completely dry and free from dust and fibers before the instrument can be reused.

12. For the next steps the teaching needles are required.

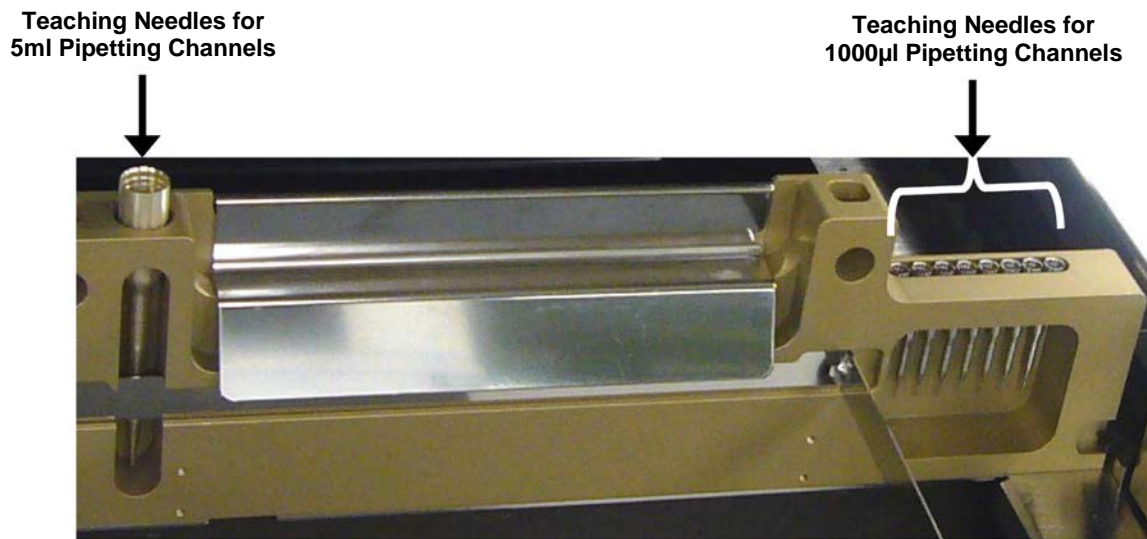

Location of Teaching Needles for Maintenance

13. The procedure continues with the tightness check of the pipetting channels. The pipetting arm will travel to the right hand side to pick up the teaching needles.

Two checks are done with the pipetting channels, the over-pressure and the under-pressure check.

14. For the capacitive liquid level detection (cLLD), check the teaching needles are picked-up again. Each pipetting channel is checked one at a time, for proper cLLD function.

15. If there is a CVS installed, a rinse procedure is started. Refer to [Section 4.14 Temperature Controlled Carrier \(TCC\)](#).

16. If there is a needle wash station installed, a weekly maintenance procedure is started. Refer to [Section 4.8 Needles](#).

17. When the weekly maintenance is completed, the “Weekly maintenance execute successfully completed” screen is displayed:

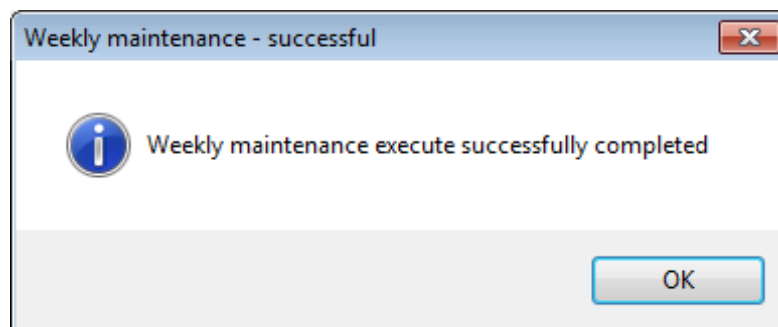

18. The weekly maintenance process status is saved on the instrument and a report file is created. Refer to [Section 4.7 Printing a Report](#).

19. Clean the tip eject sleeve (outer part of the pipetting channels) with a lint-free cloth soaked in Deconex® SOLARSEPT.

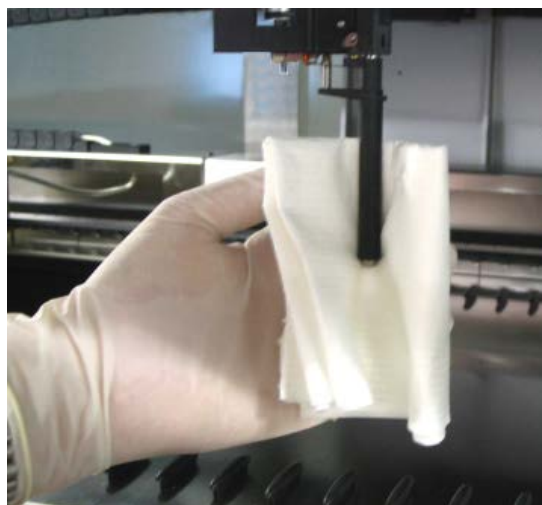

ATTENTION

Take care that no liquid gets inside the tip eject sleeve.

Whenever it is necessary to move the pipetting channels on the pipetting-arm, move them gently by pushing close to their Y-slide. Never force them as this may lead to damage. If possible, switch on the instrument as this will result in a smoother motion when the pipetting channels have to be moved on the pipetting-arm.

20. Clean the stop disk and O-rings of the pipetting head (outer part of the pipetting channels) with a lint-free cloth soaked in Deconex® SOLARSEPT.

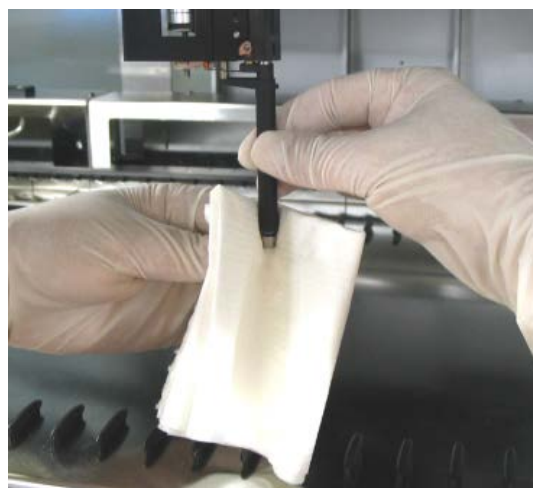

**ATTENTION**

Take care that no liquid gets inside the tip eject sleeve.

Whenever it is necessary to move the pipetting channels on the pipetting-arm, move them gently by pushing close to their y-slide. Never force them as this may lead to damage. If possible, switch on the instrument as this will result in a smoother motion when the pipetting channels have to be moved on the pipetting-arm.

21. Spray the front and side cover with Deconex® SOLARSEPT and wipe dry.
22. Clean the Autoload protecting ribbon with a cloth soaked in Deconex® SOLARSEPT, and wipe without exerting pressure.

**ATTENTION**

Do not spray directly at the Autoload or at electrical boards or connectors.

23. Clean the x-guide shaft behind the upper front cover with a dry cloth at least once a month.

**NOTE**

Carriers must be completely clean and dry before re-using.

4.7 Printing a Report

The maintenance process status can be printed. To print such a report:

1. From the “File” menu, select “Open Report”. All maintenance and verification processes which are found in the default “Report Path” are listed.
2. If necessary, change the report path using the browse button[<...>].
3. Select a report and press the **[Open]** button. The Report Viewer displays the selected report file.
4. From the “File” menu, select **[Print]** to print the report file.

4.8 Needle Maintenance

The recommended procedures for maintenance of the needles - if the needles are badly stained – are as follows:

1. Remove the needle(s) with the needle pickup tool (Needle Service Kit, see [Section 8.2.3 Teaching Needles](#)).
2. Clean the needles in an ultrasonic bath at 50°C containing Deconex® 61 DR for 15 - 20 minutes.
3. Rinse the needles with warm de-ionized water (50°C).
4. Put the needles back into the wash module.



NOTE





Hamilton recommends replacing steel needles every six months.

4.9 CO-RE 96 Probe Head TADM

This section describes the preparation and execution of the maintenance procedures for the CO-RE 96 Probe Head TADM 1000µl. For more information about the labware, please refer to the [TADM Manual](#) or the [VENUS Programmer's Manual](#).

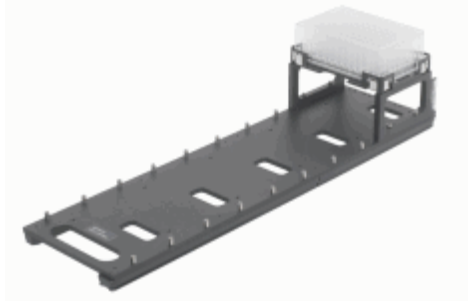
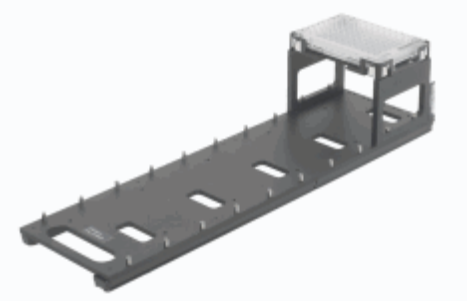
A CO-RE 96 Probe Head TADM 1000µl must be mounted in a ML STAR to perform the maintenance procedures indicated in this section.

It is required to have either of the carriers (presented in the table below) with a defined plate position for the maintenance tool.

	
<p><i>P/N 188042 MULTIFLEX DWP MODULE</i></p>	<p><i>P/N 188041 MULTIFLEX MTP MODULE</i></p>
	
<p><i>P/N 182090 PLT_CAR-L5AC</i></p>	<p><i>P/N 182365 PLT_CAR_L5MD</i></p>
	
<p><i>P/N 199199 Maintenance Tool</i></p>	

4.9.1 Preparation

To prepare for the maintenance procedure, create a System Deck Layout. Follow these steps:

1. Start the Method Editor by activating the icon shown below.



2. Open the existing deck layout found in the directory: \\HAMILTON \Methods \VM

- For the ML STARlet StarLineMaintenance_Starlet.lay
- For the ML STAR StarLineMaintenance_Star.lay
- For the ML STARPlus StarLineMaintenance_Starplus.lay

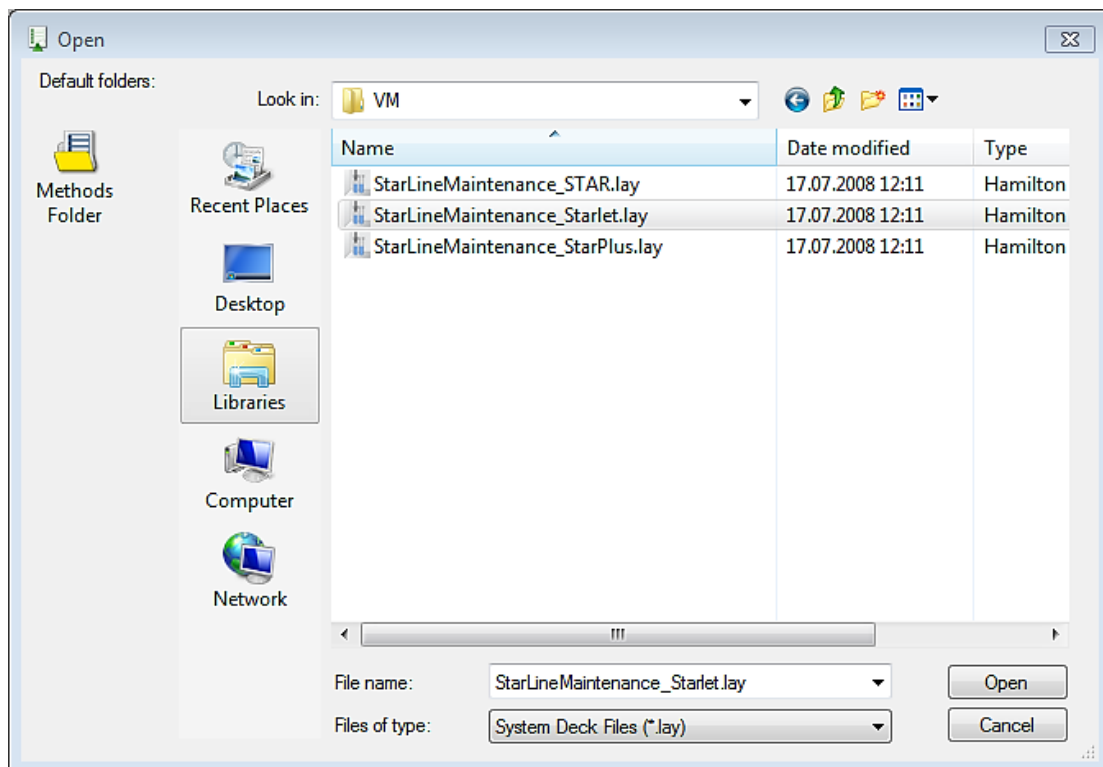

NOTE

Selecting the "Files of type" to System Deck Files (*.lay) is necessary. This will make the desired *.lay files visible and selectable.

3. Create and save a copy of the file selected. In this case, save a copy of the "StarLineMaintenance_Starlet.lay" File and name it as "StarLineMaintenance_Starlet_mod.lay". For uniformity purposes and to avoid confusion in later steps, always use the "_mod" keyword as a prefix to the file copies.

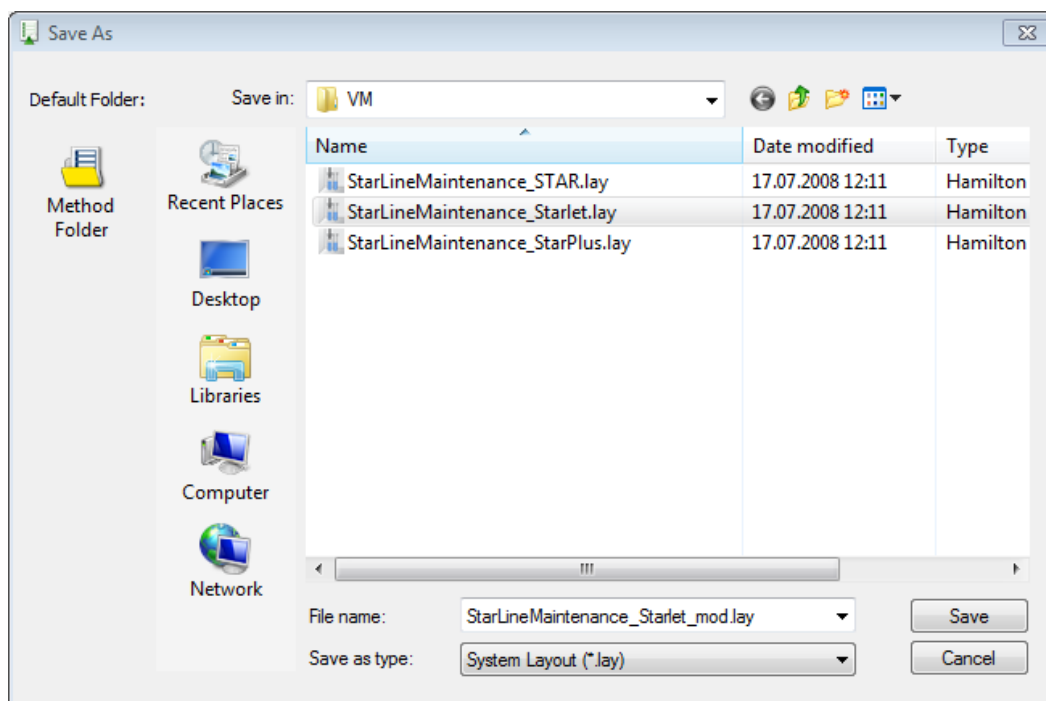
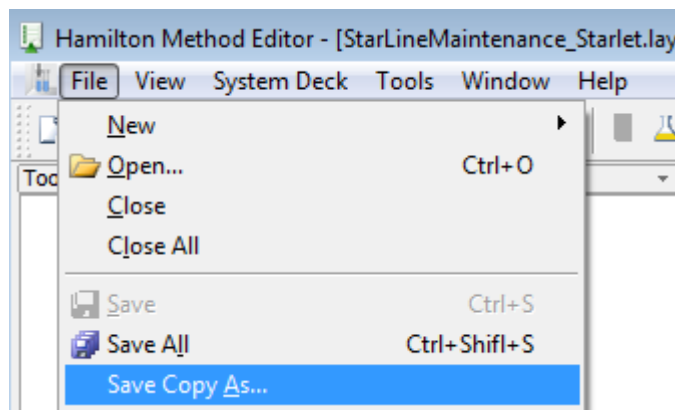

4. Open the file copy "StarLineMaintenance_Starlet_mod.lay", after successfully creating a duplicate.
5. Add the chosen plate carrier from the table, as instructed earlier. Remember to add the plate carrier onto a track position reachable by the CO-RE 96 Probe Head TADM.



NOTE

The deck position has to be available for the maintenance routine.

In this example, a PLT_CAR_L5MD (P/N 182365) has been chosen.

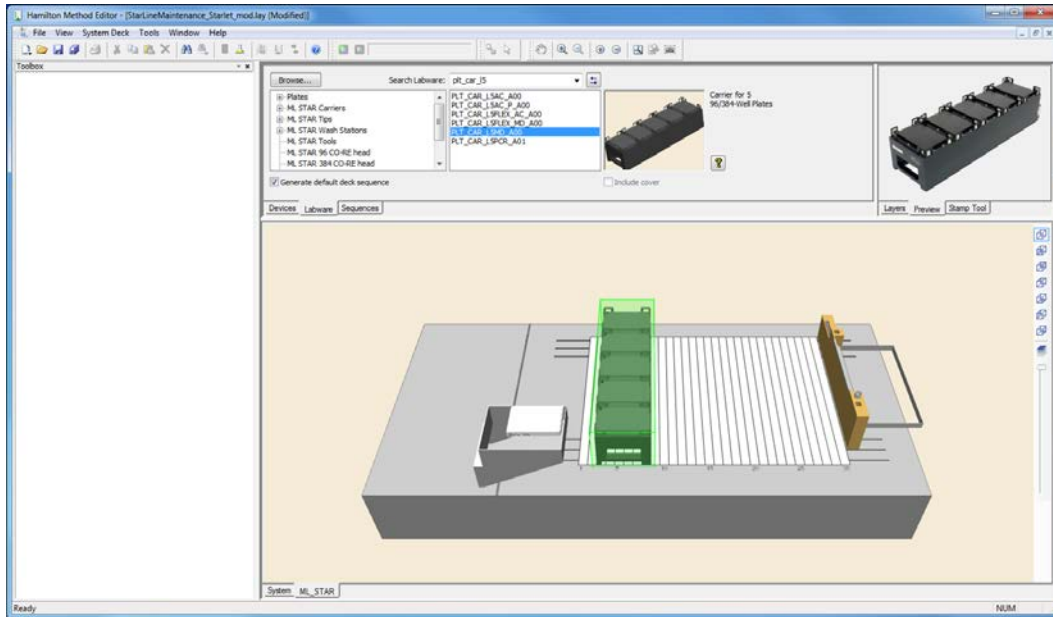

- Right click on the plate carrier and select Properties. A dialog box with predefined values will display, as shown below. Set the Labware Property “Visible by default” to Yes. This will display the carrier in the deck layout editor during the maintenance process. To close the dialog box, click **[OK]**.

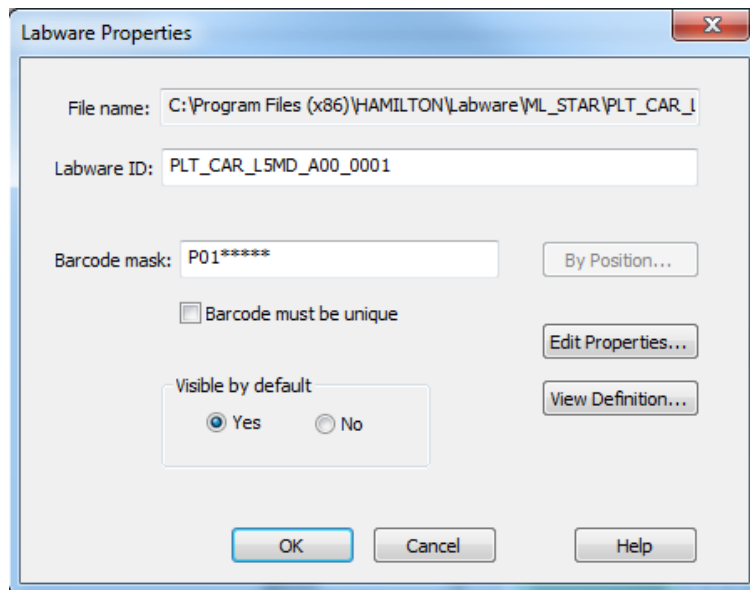

- To add the Maintenance Tool to the chosen plate carrier, click [Browse...] from the Labware Tab of the Method Editor. Locate the file by opening through the folders **Hamilton > LabWare > ML_STAR > 96COREHEAD**.

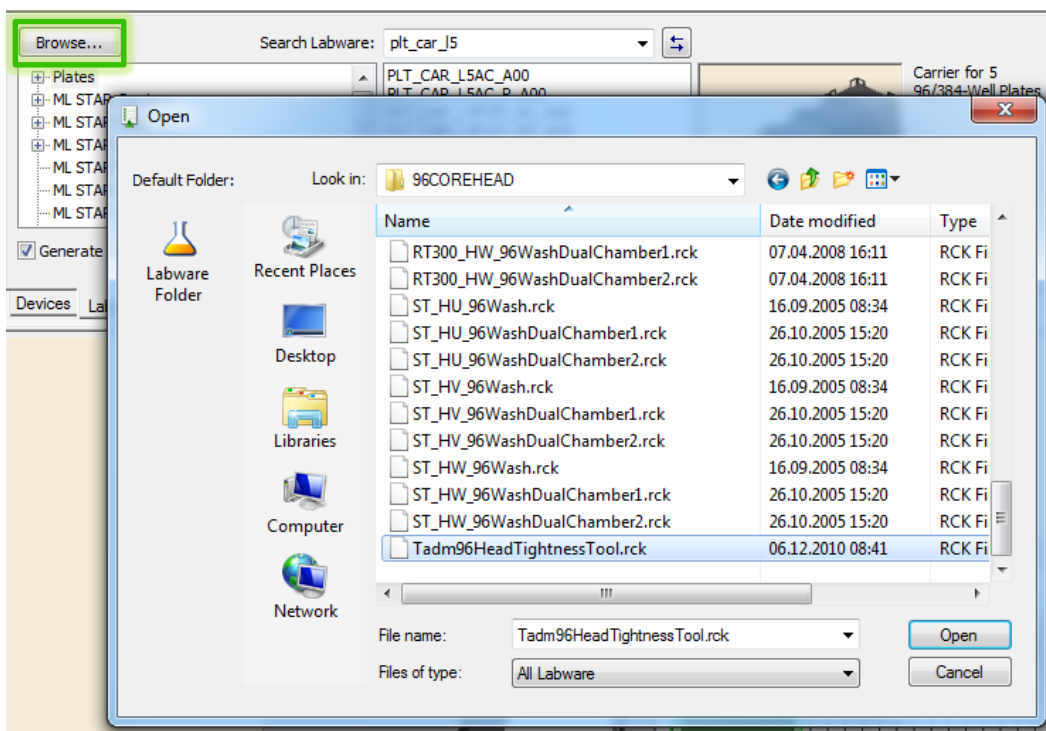

- Add the tool onto the plate carrier. Any available position on the plate carrier may be chosen.

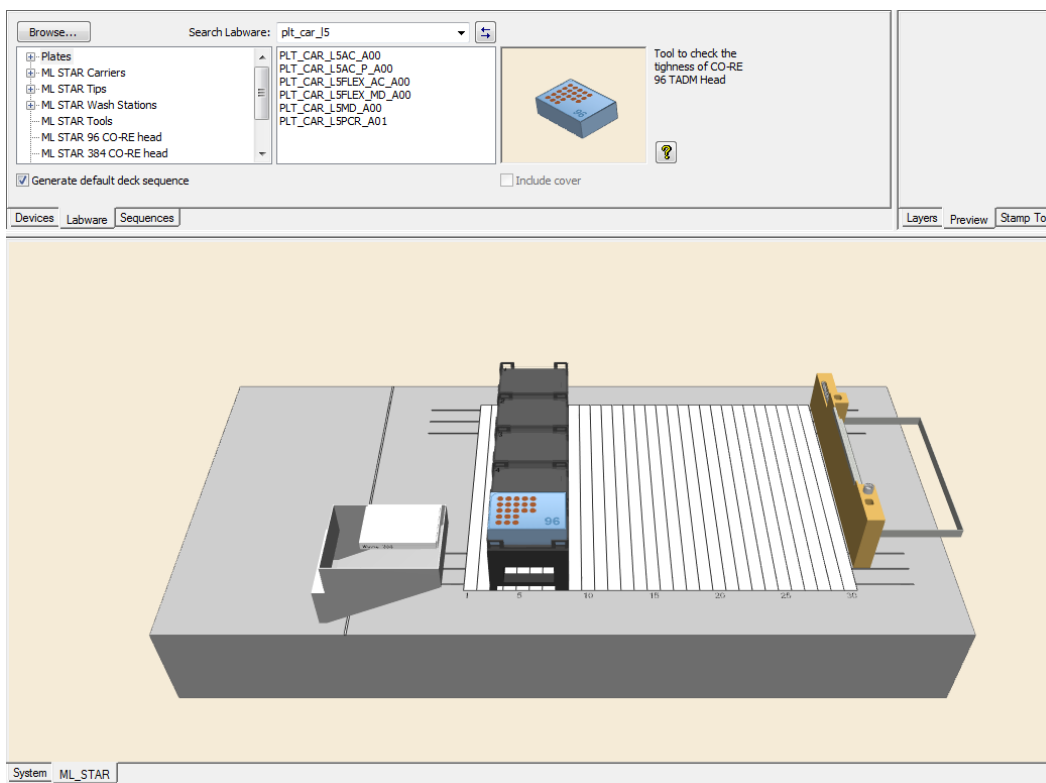

9. After having successfully added the tool onto the plate carrier, right click on it and select Properties. A dialog box with predefined values will prompt, as shown below. Set the Labware Property “Visible by default” to Yes. This will display the tool in the deck layout editor during the maintenance process. To close the dialog box, click **[OK]**.

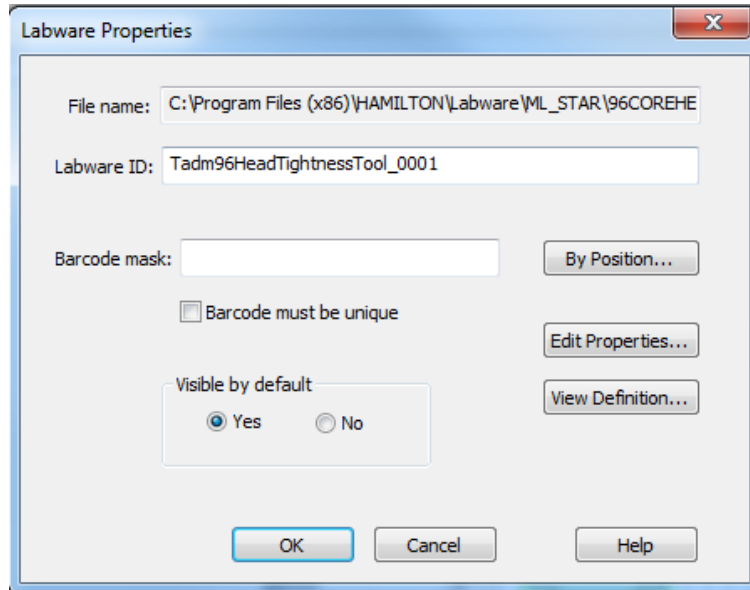

Labware Properties

File name: C:\Program Files (x86)\HAMILTON\Labware\ML_STAR\96COREHE

Labware ID: Tadm96HeadTightnessTool_0001

Barcode mask: By Position...

Barcode must be unique

Visible by default

Yes No

Edit Properties...

View Definition...

OK Cancel Help

10. Finish by saving the deck layout and closing the Method Editor.

4.9.2 Daily Maintenance

Daily maintenance requires the following tasks to be performed:

- Inspect the workspace/deck for cleanliness
- Empty the tip waste and liquid waste
- Have the instrument perform a tightness check
- Have the instrument perform a cLLD check



ATTENTION

Be aware of moving parts (i.e. X-Arm with its CO-RE 96 Probe Head TADM).

An instruction to place the carrier and the CO-RE 96 MPH Maintenance Tool onto the deck will be prompted. This step requires opening the front cover. After doing so, make sure to close the front cover. This applies to both placing and removing a carrier and a tool.

The following steps should be followed to perform the daily maintenance for the CO-RE 96 Probe Head TADM.

1. Start by activating the Microlab STAR Maintenance & Verification icon shown below.

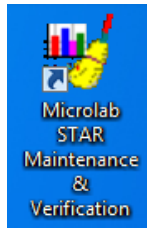

2. Now that the Hamilton Maintenance and Verification is running, select "Daily Maintenance" from the choices and start. See image below.

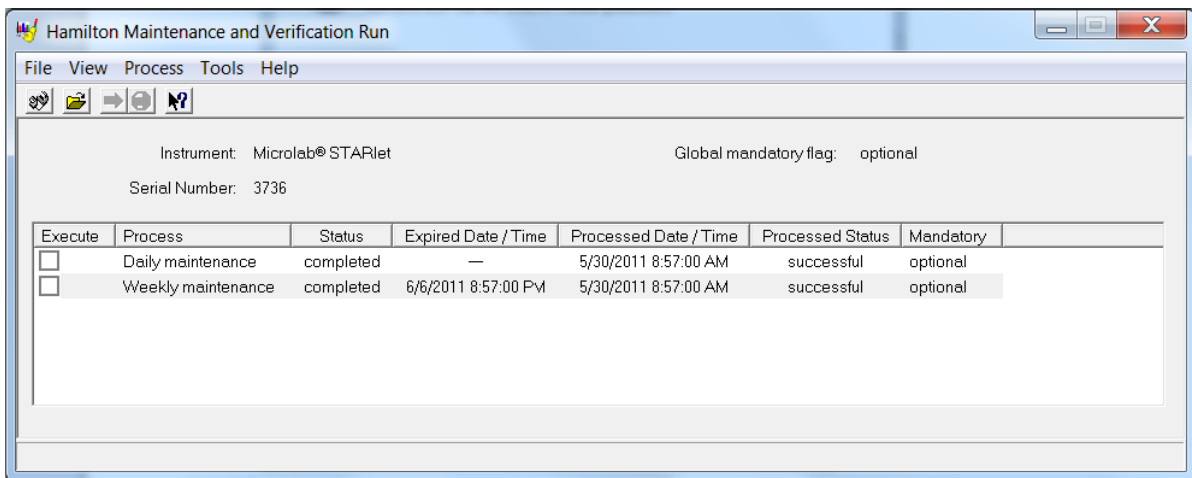

3. Follow the instructions and when prompted with the dialog box shown below, select [YES]. This will execute the CO-RE 96 Probe Head TADM tightness check.

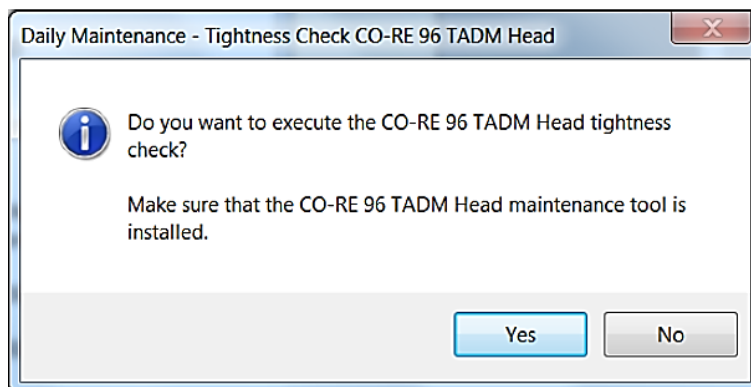

- Place the carrier with the tool onto the deck. Make sure that the tool when placed on the carrier has a "Maintenance" label engraved on it, as shown in the photo below. The position of the carrier may vary depending on how the system deck has been defined, as described in [Section 4.9.1 Preparation](#).

**NOTE**

During this step, the front cover may be opened. Once finished, make sure to close the cover. Only then continue to the next procedure.

- The CO-RE 96 Probe Head TADM will be pre-positioned above the tool. A dialog box to confirm the correct position will be prompted.

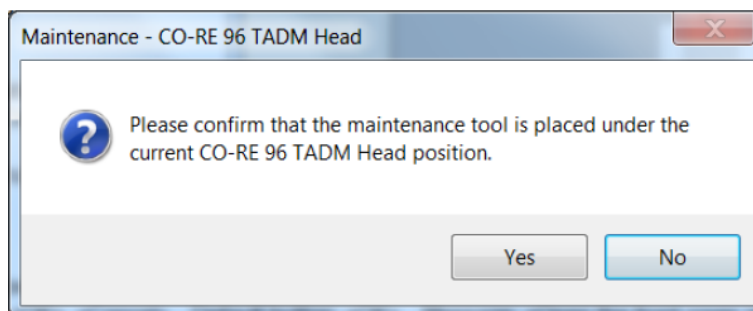
**ATTENTION**

*Selecting **[YES]** when the position is incorrect may lead to a crash and can damage the CO-RE 96 Probe Head TADM and the Tool.*

- The CO-RE 96 Probe Head TADM will pick up the Tool and the tightness check will be executed.



- Upon the completion of the tightness check, either of the following prompts will be displayed:

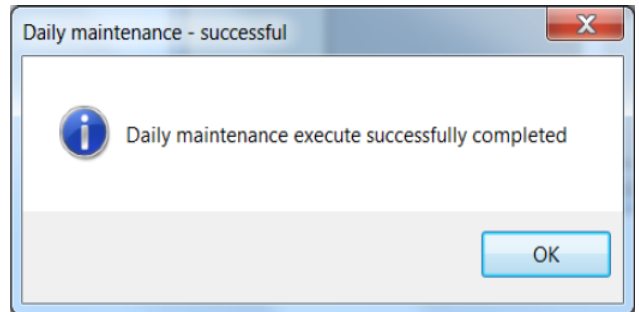
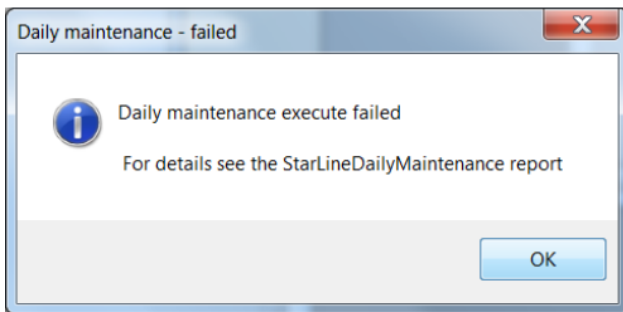

OR

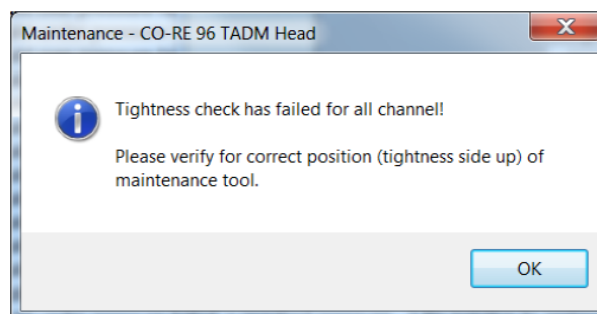

- Now, remove the carrier and the maintenance tool. The CO-RE 96 Probe Head TADM Daily Maintenance is completed.



ATTENTION

Ensure that the carrier and the tool are removed from the deck after the maintenance has been finished.

4.9.3 Weekly Maintenance

Weekly maintenance requires the following tasks to be performed:

- Clean the workspace
- Check the carriers and devices for damage
- Empty and clean the solid and liquid waste
- Clean main instrument modules thoroughly
- Clean the instrument covers
- Have the instrument perform a tightness check
- Have the instrument perform a cLLD check



ATTENTION

Be aware of moving parts (i.e. X-Arm with its CO-RE 96 Probe Head TADM).

An instruction to place the carrier and the CO-RE 96 MPH Maintenance Tool onto the deck will be prompted. This step requires opening the front cover. After doing so, make sure to close the front cover. This applies to both placing and removing a carrier and a tool.

The following steps should be followed to perform the weekly maintenance for the CO-RE 96 Probe Head TADM.

1. Start by activating the Microlab STAR Maintenance & Verification icon shown below.

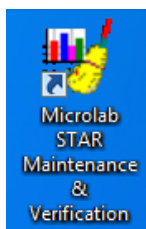

2. Now that the Hamilton Maintenance and Verification is running, select “Weekly Maintenance” from the choices and start. See image below.

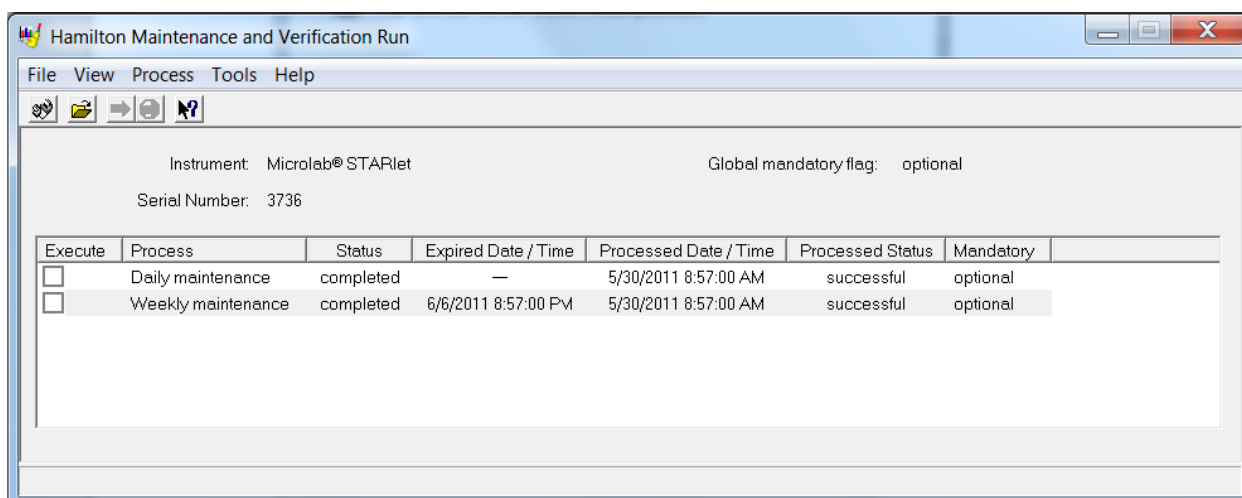

3. Follow the instructions and when prompted with the dialog box shown below, select **[YES]**. This will execute the CO-RE 96 Probe Head TADM tightness check.

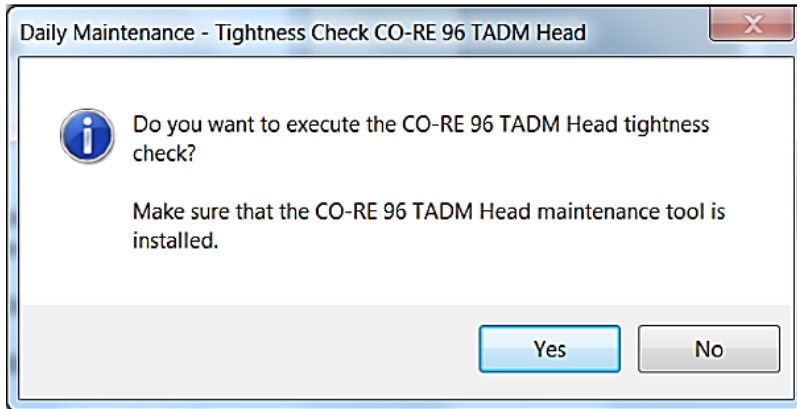

4. Place the carrier with the tool onto the deck. Make sure that the tool when placed on the carrier has a "Maintenance" label engraved on it, as shown in the photo below. The position of the carrier may vary depending on how the system deck has been defined, as described in [Section 4.9.1 Preparation](#).



NOTE

During this step, the front cover may be opened. Once finished, make sure to close the cover. Only then continue to the next procedure.

5. The CO-RE 96 Probe Head TADM will be pre-positioned above the tool. A dialog box to confirm the correct position will be displayed.

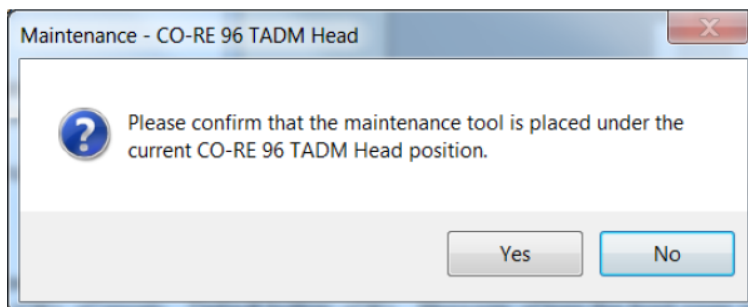

**ATTENTION**

Selecting **[YES]** when the position is incorrect may lead to a crash and can damage the CO-RE 96 Probe Head TADM and the Tool.

6. The CO-RE 96 Probe Head TADM will pick up the Tool and the tightness check will be executed.



7. Upon completion of the tightness check, either of the following prompts will be displayed:

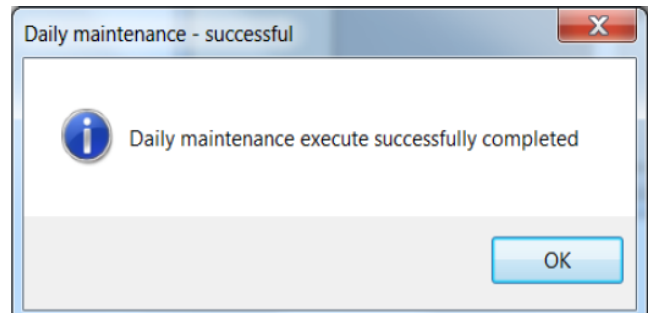
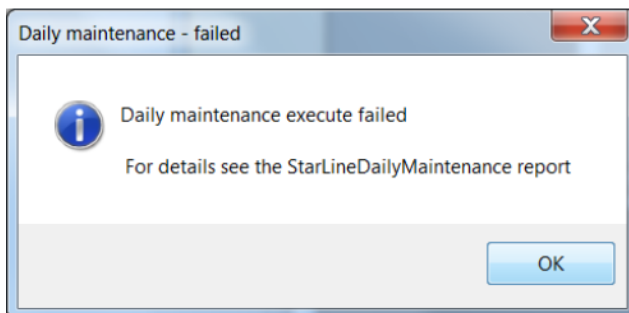

OR

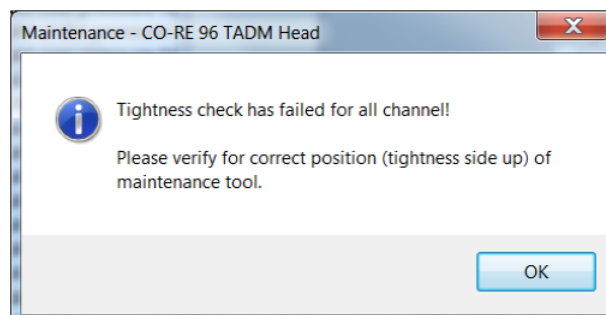

8. Now, remove the carrier and the maintenance tool. The CO-RE 96 Probe Head TADM Weekly Maintenance is completed.



ATTENTION

Ensure that the carrier and the tool are removed from the deck after the maintenance has been finished.

4.10 CR Needle Wash Station

Hamilton recommends the following daily rinse routine and the weekly maintenance procedure to maintain the functionality of the needle wash station. Excellent washing results can be achieved only with periodic maintenance.

If so configured in the VENUS Software, daily and weekly maintenance are required.

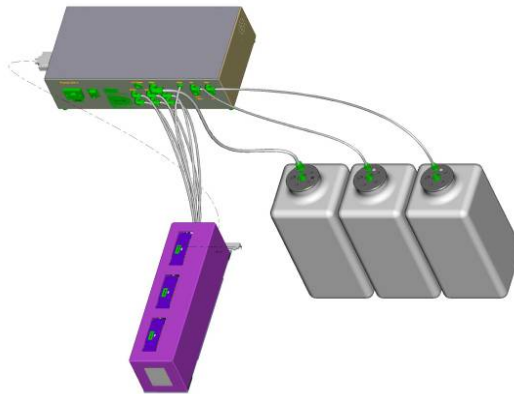

Before starting the maintenance procedures, make sure the needles to be washed are placed in the Needle Wash Station.

4.10.1 Daily Maintenance

The daily maintenance procedure for the CR needle wash station takes 15 minutes. The purpose of this procedure is to rinse the fluid path of the wash station. With this procedure, deposits inside the fluid path can be minimized. If the wash station is seriously soiled, the operator should start the weekly maintenance instead of the daily maintenance.

Empty any remaining liquid of the wash containers and the waste container. Partially fill the wash solution containers with de-ionized water. With the cap facing upwards, shake the containers in the lengthwise direction for a few moments. Empty the containers.

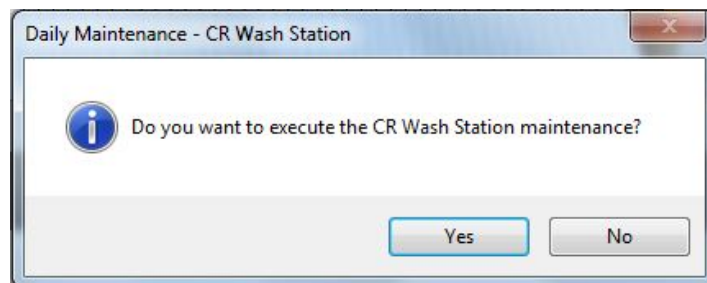

1. Once the maintenance procedure for the CR needle wash station has been started, the software advises the operator to fill Wash Container 1 (red dot on the container lid) with 4 liters of de-ionized water and 40ml of Deconex® 61 DR (P/N 281242).

2. 1x wash step (wash solution; Rinse time 60 seconds, soak time 1 second, flow rate 12 ml/second, draining time 12 seconds).
3. The rinse procedure is interrupted by the maintenance program, to advise the operator to empty wash container 1 (red dot on the container lid) and to fill it up with 3 liters of de-ionized water.
4. 2x rinse step (de-ionized water; Rinse time 60 seconds, soak time 1 second, flow rate 12 ml/second, draining time 12 seconds).
5. At the end of the daily maintenance procedure, wash container 1 and the waste container need to be emptied.

4.10.2 Weekly Maintenance

The weekly maintenance procedure for the CR needle wash station takes 40 minutes. The purpose of this procedure is to carry out periodical in-depth maintenance. The fluid path of the wash station and the needles are soaked in a special cleaning solution.

Empty any remaining liquid of the wash containers and the waste container. Partially fill the wash solution containers with de-ionized water. With the cap facing upwards, shake the containers in the lengthwise direction for a few moments. Empty the containers.

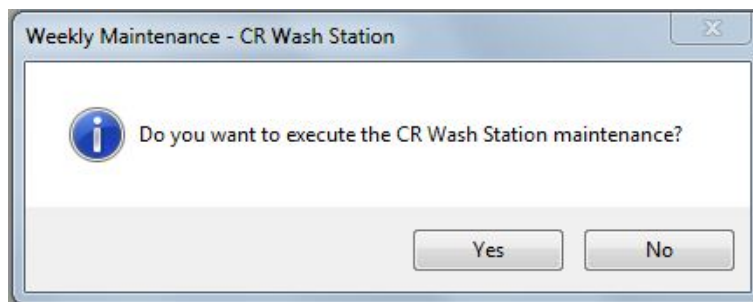

1. Once the maintenance procedure for the needle wash station has been started, the software advises the operator to fill wash container 1 (red dot on the container lid) with 6 liters of de-ionized water and 60ml of Deconex[®] 61 DR (P/N 281242).
2. 1x wash step (wash solution; Rinse time 60 seconds, soak time 300 seconds, flow rate 12 ml/second, draining time 12 seconds).
3. 1x wash step (wash solution; Rinse time 60 seconds, soak time 1 second, flow rate 12 ml/second, draining time 12 seconds).
4. The procedure is interrupted by the maintenance program to advise the operator to empty wash container 1 (red dot on the container lid) and to fill it up with 6 liters of de-ionized water. Partially fill the wash solution container with de-ionized water. With the cap facing upwards, shake the container in the lengthwise direction for a few moments. Empty the container.
5. Fill up wash container 1 with 3 liters of de-ionized water.
6. 2x rinse step (de-ionized water; Rinse time 60 seconds, soak time 1 second, flow rate 12 ml/second, draining time 12 seconds).
7. At the end of the weekly maintenance procedure, wash container 1 and the waste container need to be emptied and let them dry.

4.11 CO-RE 96/384 Dual Wash Station

Hamilton recommends the following daily rinse routine and the weekly maintenance procedure to maintain the functionality of the CO-RE 96/384 dual wash station. Excellent washing results can be achieved only with periodic maintenance.

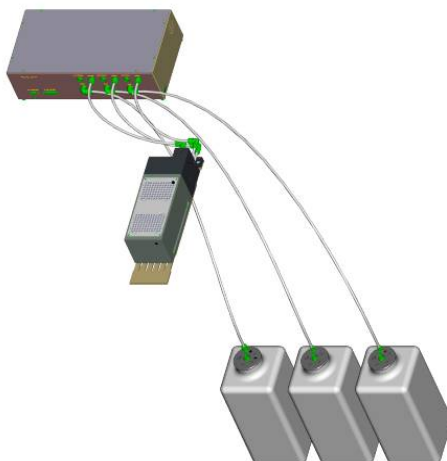

4.11.1 Daily Maintenance

The daily maintenance procedure for the wash station 96/384 takes 10 minutes. The purpose of this procedure is to rinse the fluid path of the wash station. With this procedure, deposits inside the fluid path can be minimized. If the wash station is seriously soiled, the operator should carry out the weekly maintenance instead of the daily maintenance.

Empty any remaining liquid of the wash container and waste container. Partially fill the wash solution containers with de-ionized water. With the cap facing upwards, shake the container in the lengthwise direction for a few moments. Empty the containers.

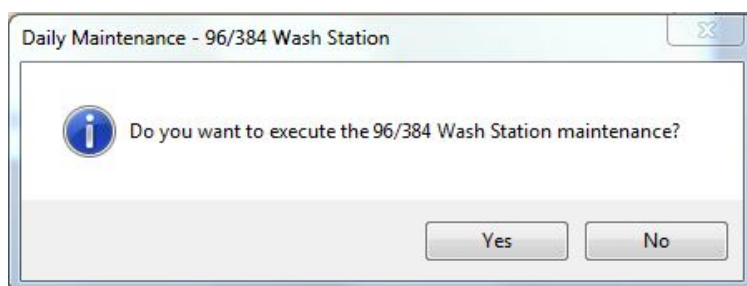

1. Fill the wash containers with 2 liters of de-ionized water and 20ml of Deconex[®] 61 DR (P/N 281242).
2. Empty the waste container.
3. 1x priming (initialize washer, empty).
4. 2x rinse step for both wash chambers (fill washer, empty).
5. Empty the wash containers. Partially fill the wash containers with de-ionized water. With the cap facing upwards, shake the containers in the lengthwise direction for a few moments. Empty the wash containers. Fill the wash containers with 3 liters of de-ionized water again.
6. 2x rinse step for both wash chambers (fill washer, empty).
7. Empty the wash containers and waste container.

8. Empty any remaining wash solution. Partially fill the containers with de-ionized water. With the cap facing upwards, shake the containers in the lengthwise direction for a few moments. Empty the containers and let them dry.

4.11.2 Weekly Maintenance

The weekly maintenance procedure for the wash station 96/384 takes 20 minutes. To guarantee excellent wash efficiency, carry out the following steps at least once a week.

Empty any remaining liquid of the wash container and waste container. Partially fill the wash solution containers with de-ionized water. With the cap facing upwards, shake the container in the lengthwise direction for a few moments. Empty the containers.

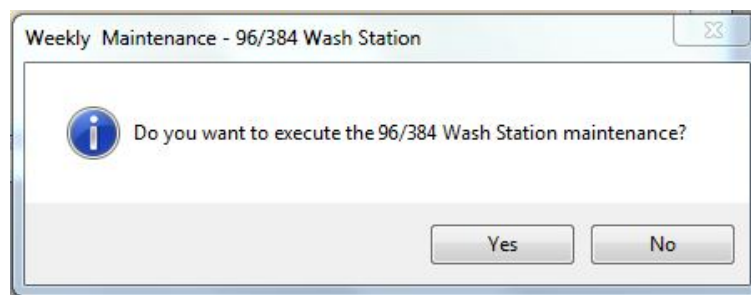

1. Fill the wash containers with 2 liters of de-ionized water and 20ml of Deconex[®] 61 DR (P/N 281242).
2. Empty the waste container.
3. 1x Priming (Initialize washer, empty).
4. 1x Rinse step for both wash chambers (fill washer).
5. Soaking: Timer of 5 minutes.
6. 1x Rinse step for both wash chambers (empty washer, refill after empty).
7. 1x Empty washer.
8. Empty the wash containers. Partially fill the wash containers with de-ionized water. With the cap facing upwards, shake the containers in the lengthwise direction for a few moments. Empty the wash containers. Fill the wash containers with 3 liters of de-ionized water again.
9. 2x rinse step for both wash chambers (Fill washer, empty).
10. 1x Empty the washer.
11. Empty any remaining wash solution of the wash and waste containers. Partially fill the containers with de-ionized water. With the cap facing upwards, shake the containers in the lengthwise direction for a few moments. Empty the containers and let them dry.

4.12 Hamilton Heater Shaker

Hamilton recommends cleaning the HHS regularly to prolong its lifespan. In case of contamination or spillages clean the HHS immediately. The HHS must be turned off and cooled down for the maintenance procedure. Follow the maintenance procedure described in the ML STAR Operator's Manual. There are no further actions required.



ATTENTION

Do not clean the HHS when it is still hot!

Wait until the HHS has cooled down to room temperature before starting the cleaning procedure. Do not soak the manifold top.

4.13 Crystal Vacuum System

The CVS has to be connected to a Hamilton waste bottle, or to a suitable in-house liquid disposal system. Hamilton recommends maintaining the CVS by following the daily and weekly maintenance procedures described below. Only with a periodical maintenance a long lifespan of the CVS can be achieved.

4.13.1 Activating the CVS Maintenance

Activating the CVS maintenance requires modification of the two source files namely "**HslStarLineMaintMetConst.hs_**" and "**HslStarLineMaintMetConst.stp**". They are available in the folder **...\HAMILTON\Library**.

The files can be modified by following the instructions below:

1. Make a copy of both HSL source files namely "**HslStarLineMaintMetConst.hs_**" and "**HslStarLineMaintMetConst.stp**".
2. After renaming the files, modify the value of the constant "**isBVSInstalled(hslFalse);**" to "**isBVSInstalled(hslTrue);**".
3. Save the files.
4. Rename the original files to "**old_ HslStarLineMaintMetConst.hs_**" and "**old_ HslStarLineMaintMetConst.stp**".
5. Finally rename the modified files generated with the original names.

4.13.2 Daily Maintenance

The daily maintenance procedure for the CVS takes 10 minutes. The purpose of this procedure is to rinse the tubing and the vacuum chamber. With this procedure, deposits inside the fluid path can be minimized. If the CVS is seriously soiled, the operator should start the weekly maintenance instead of the daily maintenance.

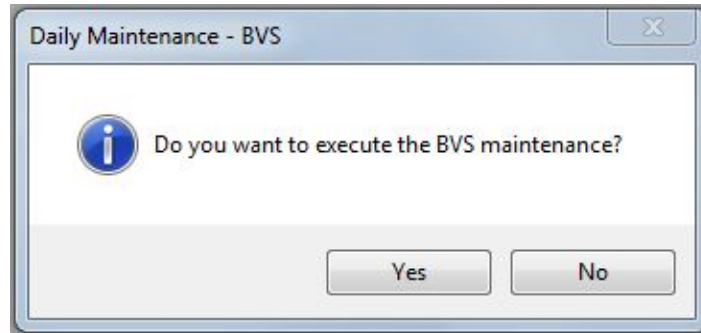

1. It is recommended to detach the Manifold Top from the vacuum module. It shall be cleaned separately to avoid water spill.
2. Prepare approximately 350ml of de-ionized water with 3.5ml of Deconex[®] 61 DR (P/N 281242). Pour the mixture into the vacuum chamber of the CVS carrier until it is full. Please do not overspill. Use a soaking time of 1 minute.
(Please keep in mind the ratio of 100ml de-ionized water:1ml Deconex[®] 61 DR).
3. Vacate the vacuum chamber.
4. Pour in de-ionized water into the vacuum chamber of the CVS carrier until it is full. Please do not overspill.
5. Vacate the vacuum chamber.
6. Empty the waste bottle. Fill the waste bottle with de-ionized water to a degree. Ensure that the waste bottle is securely closed. Shake the container in a semi-inclined position for a few moments. Empty the waste bottle.
7. Clean the Manifold Top with a lint-free cloth soaked in Deconex[®] SOLARSEPT. Rinse afterwards with de-ionized water and let dry before using it again.

4.13.3 Weekly Maintenance

The weekly maintenance procedure for the CVS takes 15 minutes time. The purpose of this procedure is to rinse the tubing and the vacuum chamber. With this procedure, deposits inside the fluid path can be minimized.

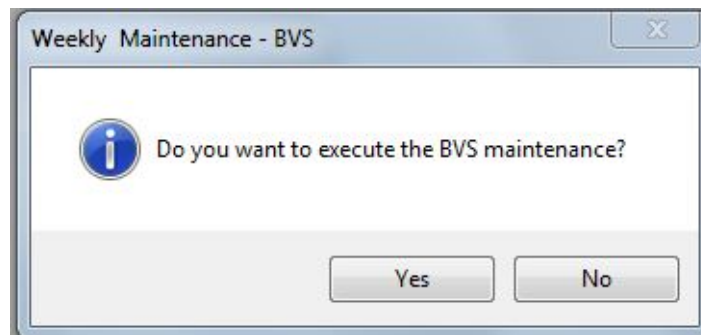

1. It is recommended to detach the Manifold Top from the vacuum module. It shall be cleaned separately to avoid water spill.
2. Prepare approximately 350ml of de-ionized water with 3.5ml of Deconex® 61 DR (P/N 281242). Pour the mixture into the vacuum chamber of the CVS carrier until it is full. Please do not overspill. Use a soaking time of 5 minutes.
(Please keep in mind the ratio of 100ml de-ionized water:1ml Deconex® 61 DR).
3. Vacate the vacuum chamber.
4. Pour in de-ionized water into the vacuum chamber of the CVS carrier until it is full. Please do not overspill.
5. Vacate the vacuum chamber.
6. Empty the waste bottle. Fill the waste bottle with de-ionized water to a degree. Ensure that the waste bottle is securely closed. Shake the container in a semi-inclined position for a few moments. Empty the waste bottle.
7. Clean the Manifold Top with a lint-free cloth soaked in Deconex® SOLARSEPT. Rinse afterwards with de-ionized water and let dry before using it again.



ATTENTION

Do not soak the manifold top.

4.14 Temperature Controlled Carrier (TCC)

Here is the recommended procedure for the daily/weekly maintenance of the TCC:

Clean all surfaces with a cloth soaked with Deconex® SOLARSEPT (see [Section 8.2.15 Liquids for Maintenance](#)).

4.15 Multiflex Cooling-Heating Module

Here is the recommended procedure for the daily/weekly maintenance of the Cooling-Heating Module:

Clean all surfaces with a cloth soaked with Deconex® SOLARSEPT (see [Section 8.2.15 Liquids for Maintenance](#)).

.

5. ML STAR Instrument Decontamination

The decontamination method must be adapted to the respective application and the substances associated with it. The user takes full responsibility for the appropriate decontamination of the entire equipment.

Apart from regular decontamination, the user must thoroughly decontaminate the instrument according to local regulations in the following cases:

- Before any maintenance or service work is performed on the instrument
- In case of accidents (e.g. crash, spilt substances, etc.)
- Before the instrument or parts of it are returned to HAMILTON (e.g. for repair)
- Prior to storage of the instrument
- Prior to disposal of the instrument or parts of it
- Generally before the instrument or parts of it leave the user's site



Note

Dilute the concentrated disinfectant agent with deionized water according to the instruction on the bottle.



ATTENTION

Risk of Damage to equipment.

Do not use cleaning or disinfecting solutions which contain hypochlorite, such as bleach.



ATTENTION

Risk of Damage to equipment.

Spraying the instrument or carriers surfaces will lead to damage of equipment.

- *Do not spray the disinfectant agent onto the instrument or carrier surfaces directly. Spray the liquid onto a paper towel to clean the surfaces and devices.*

In general, for decontamination GLP must be observed. Here is the recommended procedure for decontaminating the ML STAR instrument:

1. Spray the front and side cover with Deconex[®] SOLARSEPT (see [Section 8.2.15 Liquids for Maintenance](#)) and wipe with clean paper towels.

2. Spray lint-free paper towels with Deconex[®] SOLARSEPT (see [Section 8.2.15 Liquids for Maintenance](#)).
3. Open the front cover and wipe the deck with the paper towels.

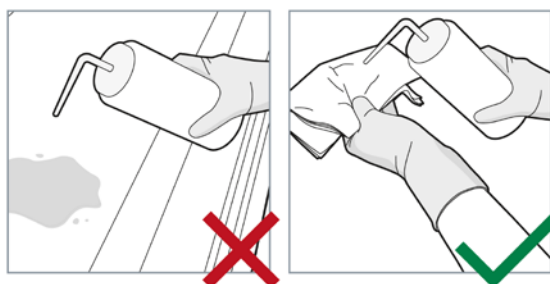

4. Remove the tip eject plate of the tip waste station and clean it.
5. Spray Deconex[®] SOLARSEPT directly onto the surface of the tip waste station.
6. Remove the frame that holds the plastic bag in place, and discard the plastic bag in the laboratory's contaminated waste. Put the tip eject plate back in place.

7. Clean the tip eject sleeve (outer part of the pipetting channels) with a lint-free paper towel soaked in Deconex[®] SOLARSEPT (see [Section 8.2.15 Liquids for Maintenance](#)).

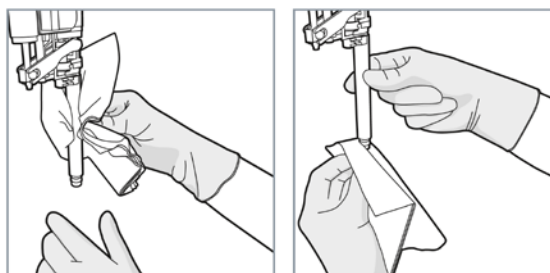

8. Lift up the tip eject sleeve and wipe the o-ring and stop disk.
9. Repeat this procedure for all pipetting channels.

10. The use of disinfectant liquids is recommended for decontamination of Carriers. Clean all carriers with Deconex[®] SOLARSEPT (see [Section 8.2.15 Liquids for Maintenance](#)) and leave them to dry. If they are heavily soiled, soak them afterwards in a solution of Deconex[®] 61 DR (see the [product data sheet](#) for further information).
11. Perform needle maintenance (see [Section 4.8 Needles](#)).
12. Perform washer maintenance (see [Section 4 Maintenance](#) and the following sections).



ATTENTION

Autoclaving (i.e. using superheated steam under pressure) may only be used for decontamination followed by final disposal of disposables and racks; they will be destroyed by the process. Autoclaving cannot be used for instrument components or accessories (pipetting channels, transport tools, wash station components, heaters, shakers, carriers, etc.).



ATTENTION

In some cases, other decontamination procedures may be desirable (e.g. for reliably destruction of infectious materials or DNA/RNA). Many of these decontamination procedures are very aggressive and can cause damage to the ML STAR instrument. Please follow the guideline given below. If using other decontamination procedures not listed here, be aware that they may increase service and maintenance requirements and may make shorter maintenance intervals necessary.

5.1 Surface Decontamination using Liquids

Preferably, use the procedure using Deconex[®] 61 DR or Deconex[®] SOLARSEPT described above. Other procedures have not been tested by Hamilton. Use Deconex[®] 61 DR at a maximum temperature of 50°C.

If using other liquids or sprays for surface decontamination, follow the manufacturer's instructions. Pay particular attention to potential corrosiveness (e.g. acidic or alkaline solutions and oxidizing agents). Use of such agents may increase service and maintenance requirements (O-rings exchange, greasing of spindles, etc.) and may make shorter maintenance intervals necessary. Do not use disinfecting materials which contain hypochlorite (Javel water, Chlorox) or bleaching fluids. If possible, use non corrosive, neutral liquids.

When the instrument deck and carriers are cleaned using enzyme solutions such as DNase and RNase, make sure to thoroughly remove any remaining residue afterwards by wiping deck and carriers with deionized water in order to avoid aggressive substances left on the surface.

5.2 Decontamination using Gases

Should decontamination by fumigation be necessary, Hamilton recommends using ethylene oxide. Be aware that ethylene oxide fumigation may increase service and maintenance requirements (O-rings exchange, greasing of spindles, etc.) and may make shorter maintenance intervals necessary. Hamilton does not carry out such fumigation procedures, please use a 3rd party contractor for such service.

Fumigation using hydrogen peroxide (H₂O₂) is possible, but leads to bleaching or discoloration of many instrument materials. Be aware that hydrogen peroxide fumigation may increase service and maintenance requirements (O-rings exchange, greasing of spindles, etc.) and may make shorter maintenance intervals necessary. Hamilton does not carry out such fumigation procedures, please use a 3rd party contractor for such service.

Do not use formaldehyde fumigation or chlorine oxides (chemical compounds of chlorine and oxygen such as bleach). They are not suitable for the ML STAR instrument because of chemical reaction and corrosion.

5.3 Decontamination using UV Light

Hamilton offers a UV Light option for ML STAR instruments. We recommend UV radiation for 15 minutes and moving the arm left and right while the UV-lamp is on.

If using other UV radiation options, use wavelength, intensity and duration according to manufacturer's instructions.

Be aware that UV radiation causes many synthetic materials to become brittle. This may increase service and maintenance requirements and may make shorter maintenance intervals necessary. The instrument cover should be made of UV resistant acrylic glass, not of standard acrylic glass, due to its better resistance to UV radiation.

6. Verification

6.1 General Description

To perform the verification of the ML STAR instrument, "Field Verification 2" is used. The Field Verification 2 can only be performed by a Hamilton trained field service engineer.

Verification specifications (as applicable in the [Microlab STAR Field Verification 2 User Manual](#)) are different from the specifications given in the technical specifications of this user manual.

Especially the volume verification specifications (as applicable in the [Microlab STAR Field Verification 2 User Manual](#)) are different from the pipetting specifications for disposable tips given in the technical specifications of this user manual. The field verification contains validated procedures and equipment defined by Hamilton to demonstrate and to verify the correct function of the instrument according to specifications given by Hamilton suitable for the field. The field verification is therefore a reference defined by Hamilton to compare the instrument's performance according to given procedures valid for a broad operating range.

Based on that, specifications as applicable in the technical specifications will be achieved by maintaining defined environmental conditions in the laboratory, by keeping the operating range as small as possible, by optimizing the methods such as adapting the liquid classes, knowing the sample liquids and the characteristics of used labware, etc. See also [Section 1 General Information](#).

For the 1000µl-pipetting channels, the CO-RE 96 Probe Head and the CO-RE 384 Probe Head, a dye-pipetting procedure followed by gravimetric and photometric analysis is used to verify the trueness and precision. The 5ml-pipetting channels are verified by a gravimetric approach.

Devices such as Heater Shaker, Cooler, barcode reader and cover safety can also be verified with the "Field Verification 2".

Further information can be found in [Section 8.2 Ordering Information](#) of this manual; for additional information, consult a local Hamilton representative.

7. Technical Specifications

7.1 Basic ML STAR Specifications

(for detailed information on configurations, see Section 8.3 Instrument Dimensions)			
Instrument Dimensions:	Width (x):	Height (z):	Depth (y):
STARlet	1124mm (1450mm with Multi Probe Head)	903mm	795mm (Autoload: 1006mm)
STAR	1664mm (1450mm with Multi Probe Head)	903mm	795mm (Autoload: 1006mm)
STARPlus	2160mm (2486mm with Multi Probe Head)	903mm	795mm (Autoload: 1006mm)
Work Area Dimensions:	Width (x):	Height (z) ¹⁾ :	Depth (y):
STARlet	675mm	136mm	465mm
STAR	1215mm	136mm	465mm
STARPlus	1705mm	136mm	465mm
Weight:	8 Pipetting Channels	Multi Probe Head and 8 Individual Pipetting Channels	
STARlet	135kg	150kg	
STAR	145kg	160kg	
STARPlus	205kg	220kg	
Deck Capacity:	<p>STARlet</p> <p>30 Tracks (T) allow combinations of:</p> <ul style="list-style-type: none"> Maximum of 30 Tube Carriers (1 T) holding 24 or 32 Tubes per Carrier Maximum of 5 Carriers (6 T) holding 5 Tip Racks or 5 Plate Positions per Carrier <p>STAR</p> <p>54 Tracks (T) allow combinations of:</p> <ul style="list-style-type: none"> Maximum of 9 Carriers (6 T) holding 5 Tip Racks or 5 Plate Positions per Carrier <p>STARPlus</p> <p>71 Tracks (T) allow combinations of:</p> <ul style="list-style-type: none"> Maximum of 11 Carriers (6 T) holding 5 Tip Racks or 5 Plate Positions per Carrier 		
Modal Precision:	x-y-z positional accuracy of 0.1mm		
Tip Sizes:	Low Volume: 10µl, Intermediate Volume 50µl, Standard Volume: 300µl, High Volume: 1000µl		
Needle Sizes:	Low Volume: 10µl, Standard Volume: 300µl, High Volume: 1000µl, Needles available only for 1000µl Single Pipetting Channels		
Power Consumption:	Standby Power Consumption: 100 VA Maximum Power Consumption 600 – 1000 VA, depending on configuration		

¹⁾ The maximum height for labware which can be used on the deck is 140mm

7.2 Pipetting Specifications

7.2.1 Disposable Tips with 1000µl Pipetting Channels

Pipetting Specifications for Disposable Tips*	Disposable Tip Size	Volume	Trueness R (%)	Precision CV (%)
Individual 1000µl-Pipetting Channels	10µl	0.5µl	10.0%	6.0%
	10µl	1µl	5.0%	4.0%
	10µl	5µl	2.5%	1.5%
	10µl	10µl	1.5%	1%
	50µl	0.5µl	10.0%	6.0%
	50µl	1µl	5.0%	4.0%
	50µl	5µl	2.5%	1.5%
	50µl	50µl	2.0%	0.75%
	300µl	10µl	5.0%	2.0%
	300µl	50µl	2.0%	0.75%
	300µl	200µl	1.0%	0.75%
	1000µl	10µl	7.5%	3.5%
	1000µl	100µl	2.0%	0.75%
* Test Criteria Available Upon Request	1000µl	1000µl	1.0%	0.75%
For pipetting of less than 10µl, Hamilton recommends 10µl/ 50µl Volume Disposable Tips to achieve the highest pipetting precision.				

7.2.2 Needles with 1000µl Pipetting Channels

	Needle Size	Volume	Trueness R (%)	Precision CV (%)
Individual 1000µl-Pipetting Channels	10µl	1µl	5.0%	8.0%
	10µl	5µl	2.5%	2.0%
	10µl	10µl	1.5%	1.0%
	300µl	5µl	8.0%	8.0%
	300µl	50µl	2.0%	2.0%
	300µl	200µl	1.0%	1.0%
	1000µl	50µl	5.0%	3.0%
* Test Criteria Available Upon Request	1000µl	100µl	3.0%	2.0%
	1000µl	1000µl	2.0%	1.0%

7.2.3 Disposable Tips with 5ml Pipetting Channels

Pipetting Specifications for 5ml Disposable Tips*	Disposable Tip Size	Volume	Trueness R (%)	Precision CV (%)
Individual 5ml-Pipetting Channels * Test Criteria Available Upon Request	5ml	50µl	5.0%	2.5%
	5ml	500µl	2.0%	1.5%
	5ml	1000µl	1.5%	1.0%
	5ml	5000µl	1.0%	0.5%

7.2.4 Disposable Tips with 1000µl CO-RE 96 Probe Head

CO-RE 96 Probe Head Pipetting Specifications for Disposable Tips*	Disposable Tip Size	Volume	Trueness R (%)	Precision CV (%)
1000µl CO-RE 96 Probe Head Maximum pipetting volume: 1000µl * Test Criteria Available Upon Request	10µl	1µl	5.0%	5.0%
	10µl	5µl	2.5%	2.0%
	10µl	10µl	1.5%	1.5%
	50µl	1µl	5.0%	5.0%
	50µl	5µl	2.5%	2.0%
	50µl	50µl	1.5%	1.0%
	300µl	10µl	3.0%	2.0%
	300µl	50µl	1.5%	1.0%
	300µl	300µl	1.0%	1.0%
	1000µl	10µl	7.5%	3.5%
	1000µl	100µl	2.0%	1.0%
1000µl	1000µl	1.0%	1.0%	
For pipetting of less than 10µl, Hamilton recommends 10µl/50µl Volume Disposable Tips to achieve the highest pipetting precision.				

7.2.5 Disposable Tips with 50µl CO-RE 384 Probe Head

CO-RE 384 Probe Head Pipetting Specifications for Disposable Tips*	Disposable Tip Size	Mode: Volume	Precision CV (%)
50µl CORE 384 Probe Head Maximum Pipetting Volume: 50µl  NOTE <i>Trueness is corrected in the Liquid Classes.</i> * Test criteria available upon request	50µl	Surface: 0.1µl	8.0%
	50µl	Surface: 0.5µl	6.0%
	50µl	Surface: 1µl	3.5%
	50µl	Jet: 1µl	15.0%
	50µl	Surface: 5µl	3.0%
	50µl	Jet: 5µl	4.0%
	50µl	Surface: 10µl	2.0%
	50µl	Jet: 10µl	3.0%
	50µl	Surface/Jet: 50µl	2.0%

7.2.6 Disposable Tips with 50µl CO-RE 384 Probe Head as 96 Probe Head

Disposable Tips with 50µl CO-RE 384 Probe Head as 96 Probe Head	Disposable Tip Size	Mode: Volume	Precision CV (%)
Maximum Pipetting Volume: 300µl	300µl Rocket	2µl	4.0%
	300µl Rocket	5µl	2.0%
	300µl Rocket	10µl	2.0%
	300µl Rocket	100µl	2.0%
	300µl Rocket	300µl	2.0%

7.2.7 Operating Data for Tips

Operating Data for Tips	Temperature Range:	+15°C – +25°C
-------------------------	--------------------	---------------

7.2.8 Storage Data for Tips

Storage Data for Tips	Temperature :	Max. +55°C
-----------------------	---------------	------------

7.3 Liquid Level Detection

Liquid Level Detection:	<p>Individual Pipetting Channels:</p> <ul style="list-style-type: none"> • Capacitive Liquid Level Detection (cLLD) • Pressure Liquid Level Detection (pLLD) on Aspiration, cLLD on Dispense • Minimum Volume 10µl, depending on container type <p>CO-RE 96 Probe Head:</p> <ul style="list-style-type: none"> • Capacitive Liquid Level Detection (cLLD) <p>CO-RE 384 Probe Head:</p> <ul style="list-style-type: none"> • Capacitive Liquid Level Detection (cLLD)
--------------------------------	-------------------------------------------------------------------------------------------------------------------------------------------------------------------------------------------------------------------------------------------------------------------------------------------------------------------------------------------------------------------------------------------------------------------------------------------------------------------------------------------------------------------------------------

7.4 Throughput

Throughput:	<p>8-Pipetting Channels:</p> <ul style="list-style-type: none"> To fill one 96-Well Microplate with 100µl Samples (new tip for each sample): 320 seconds Aliquot Reagent to a 96-Well Microplate (< 90µl per well): 60 seconds <p>CO-RE 96 Probe Head:</p> <ul style="list-style-type: none"> Replication of one 96-Well Microplate: 100µl, new tips, with cLLD on Aspiration: 35 seconds Reformatting of 4 – 96-Well Microplates to one 384 Well Microplate: 50µl, new tips, with cLLD on Aspiration: 140 seconds <p>CO-RE 384 Probe Head:</p> <ul style="list-style-type: none"> Replication of one 384-Well Microplate: 20µl, new tips, with cLLD on Aspiration: 35 seconds Reformatting of 4 – 384-Well Microplates to one 1536-Well Microplate: 10µl, new tips, with cLLD on Aspiraton: 140 seconds
Labware:	All SBS standard plate types up to 1536 wells and most commercially available tube types
Carriers:	For all standard labware formats and according to customer requirements.

7.5 Operating Data

Operating Data:	Maximum Power Consumption:	600 VA or 1000 VA (Depending on Configuration)
	Voltage:	115 VAC / 230 VAC (± 10%)
	Frequency:	50/60 Hz
	Delayed Action Fuse :	
	1 Power Supply – 600 VA:	115 VAC: 6.3A (T6.3AL250) 230 VAC: 3.15A (T3.15AL250)
	2 Power Supplies – 1000 VA:	115 VAC: 10A (T10AL250) 230 VAC: 5A (T5AL250)
	Installation Category:	II
	Pollution Degree:	2
	Temperature Range:	15°C – 35°C
	Relative Humidity:	30% – 85% (non-condensing, indoors)
	Noise Level:	< 65 dBA (regarding EN27779) < 46 dBA in standby mode
	Altitude:	Maximum 2000 meters above sea level
	Heat: (The Power Consumed will be Transferred to Heat)	(e.g. 600 or 1000 Watts of Heat = 600 or 1000 Joules/ Second)
	Indoor Use Only	

7.6 Storage and Transportation

Transportation and Storage:	Temperature Range:	-25°C – +70°C
	Relative Humidity:	10% – 90% (non-condensing, indoors)

7.7 Lifespan

Lifespan	7 Years based on 8 hours/day, 5 days/week
----------	-------------------------------------------

7.8 Materials Used in ML STAR Line Instruments and Accessories

Materials used in the ML STAR Line Instruments and Accessories	Steel: 1.4301, 1.4305, 1.4310, 1.4435 Aluminum: AA 5083.0, various anodizing Bronze Brass Brazing solder: Zinc Plastics: PE, PP, PTFE, PEEK, FFPM, EPT, EPDM, FPM, NBR, POM, PCDF, FFKM, Hypalon, SI, Kapton, Polyamide PCBs
----------------------------------------------------------------	------------------------------------------------------------------------------------------------------------------------------------------------------------------------------------------------------------------------------------------------

7.9 Communication

Communication	USB or RS232 with Dual Processor Board Ethernet or USB with LAN Dual Processor Board
---------------	-----------------------------------------------------------------------------------------

7.10 PC Minimum Requirements

PC Minimum Requirements	3GHz Processor, ≥ 4GB RAM, 500GB HD, 16x DVD+/-RW DirectX 9 250MB Graphics Card Windows 7 Professional or Ultimate, 32 bit or 64 bit or Windows 10 Professional or Ultimate, 32 bit or 64 bit (not included in shipment)
-------------------------	-----------------------------------------------------------------------------------------------------------------------------------------------------------------------------------------------------------------------------------------

7.11 Hamilton Standard PC Specifications Windows 7

<p>Compatible with: VENUS two, VENUS three and VENUS four</p>	<p>Desktop Computer Windows 7, 64 Bit</p>
<p>Configuration Overview</p>	<p>OptiPlex XE2 Minitower</p> <ul style="list-style-type: none"> • 4th Gen Intel Core I7-4770S Processor (Quad Core HT, 3.10GHz Turbo, 8MB, w/ HD Graphics 4600) • 8GB (2x4GB) 1600Mhz DDR3 Non-ECC • 2x 500GB 3.5inch Serial ATA (7,200 rpm) Hard Drive – RAID1 • 16X Half Height DVD +/- RW Drive • 1GB AMD Radeon R6 240, 1GB Full Height (PP & DVI-I) • Broadcom NetXtreme 10/100/1000 PCIe Gigabit Networking Card, Full Height • 2 Ethernet Network Connectors • 4x USB 2.0 Connector x2 • 4x USB 3.0 Connector x2 • 4-Port, I/O Serial Card; in total 5 Serial Connectors • Wide Screen MONITOR LED 21.5" • Country specific keyboard and Mouse • Mousepad HAMILTON • Webcam 1.3MP USB 2.0 • Soundbar Stereo USB • Windows embedded standard 7/64 bit runtime (WS7P) "P" or Windows 10 • Microsoft Excel 2013 • 5 Yr. ProSupport and Next Business Day On-Site Service • 5 Yr. Data Protection – Keep Your Hard Drive • For additional RS232 Ports, P/N 396247 (+2) or P/N 396250 (+8) can be ordered • Country-specific Mains Power Cables (for computer and monitor) are not included and must be ordered separately • Additional programs must be obtained locally

7.12 Hamilton Standard PC Specifications Window 10

Compatible with: VENUS four	Desktop Computer Windows 10, 64 Bit
Configuration Overview	<p>OptiPlex XE2 Minitower</p> <ul style="list-style-type: none"> • 4th Gen Intel Core I7-4770S Processor (Quad Core HT, 3.10GHz Turbo, 8MB, w/ HD Graphics 4600) • 8GB (2x4GB) 1600Mhz DDR3 Non-ECC • 2x 500GB 3.5inch Serial ATA (7,200 rpm) Hard Drive – RAID1 • 16X Half Height DVD +/- RW Drive • 1GB AMD Radeon R6 240, 1GB Full Height (PP & DVI-I) • Broadcom NetXtreme 10/100/1000 PCIe Gigabit Networking Card, Full Height • 2 Ethernet Network Connectors • 4x USB 2.0 Connector x2 • 4x USB 3.0 Connector x2 • 4-Port, I/O Serial Card; in total 5 Serial Connectors • Wide Screen MONITOR LED 21.5” • Country specific keyboard and Mouse • Mousepad HAMILTON • Webcam 1.3MP USB 2.0 • Soundbar Stereo USB • Windows embedded standard 7/64 bit runtime (WS7P) “P” or Windows 10 • Microsoft Excel 2013 • 5 Yr. ProSupport and Next Business Day On-Site Service • 5 Yr. Data Protection – Keep Your Hard Drive • For additional RS232 Ports, P/N 396247 (+2) or P/N 396250 (+8) can be ordered • Country-specific Mains Power Cables (for computer and monitor) are not included and must be ordered separately • Additional programs must be obtained locally

7.13 Touch Screen Monitor Specifications for the ML STAR Line

Screen Size:	21.5"	Technology:	AccuTouch Five-Wire Resistive
Resolution:	1920 x 1080	Colors:	Up to 16.2 million
Interfaces:	1x VGA HD D-Sub	Voltage:	115 VAC / 230 VAC (± 10%)
Brightness:	1x USB Type A 1x serial RS-232 211 cd/m ²	Frequency:	50/60 Hz
		Consumption:	50 W
		# of Touches:	35 Million
Contrast:	550:1	Certification:	FCC Class B, CE, IC Class B, UL, TUV GS, VCCI Class B ITE, cUL, C-Tick Class B, RoHS
Viewing Angle:	± 70° Horizontal +75°/-60° Vertical	Weight:	7.9kg

7.14 CR Needle Wash Station Specifications

Specification	Needle Capacity:	24 per Wash Station 8 per Chamber
	Wash Time (typical):	45 seconds / cycle
	Liquid Consumption (typical):	100ml / cycle
	Carryover (typical):	1000µl Needle, 100µl: <3*10 ⁻⁶ 300µl Needle, 100µl: <2*10 ⁻⁶ 10µl Needle, 10µl: <5*10 ⁻⁶
	Deck Capacity:	6 Tracks
	Maximum Units:	2 per Instrument
	Operating Data	Maximum Power Consumption:
Voltage:		115 VAC / 230 VAC (± 10%)
Frequency:		50/60 Hz
Delayed Action Fuse:		115 VAC: 3.15A (T3.15L250) 230 VAC: 1.6A (T1.6AL250)
Installation Category:		II
Pollution Degree:		2
Temperature Range:		15°C – 35°C
Relative Humidity:		30% – 85% (non-condensing, indoors)
Altitude:		Maximum 2000 meters above sea level
Indoor Use Only		
Storage and Transportation	Temperature Range:	-25°C – +70°C
	Relative Humidity:	10% – 90% (non-condensing, indoors)

7.15 CO-RE 96/384 Dual Wash Station Specifications

Specification	Wash Time (typical):	67 seconds / 2 cycles (96x10 tip) 71 seconds / 2 cycles (96x300 tip) 73 seconds / 2 cycles (384x30 tip)
	Liquid Consumption (typical):	880ml / 2 cycles
	Carryover (typical):	
	2 Cycles:	10µl Tips, 10µl: < $3 \cdot 10^{-6}$
		300µl Tips, 300µl: < $5 \cdot 10^{-6}$
		50µl Tips: < $1.8 \cdot 10^{-5}$
	3 Cycles:	50µl Tips: < $1 \cdot 10^{-6}$
	Deck Capacity:	6 Tracks
	Maximum Units:	3 per Instrument
Operating Data	Power Consumption:	41 V / 100 VA (Maximum) Supplied by the ML STAR
	Temperature Range:	15°C – 35°C
	Relative Humidity:	30% – 85% (non-condensing, indoors)
	Altitude:	Maximum 2000 meters above sea level
	Indoor Use Only	
Storage and Transportation	Temperature Range:	-25°C to +70°C
	Relative Humidity:	10% – 90% (non-condensing, indoors)

7.16 iSWAP Specifications

Plate Format:	Microplate Footprint Plate Height \leq 43mm		
Absolute Positioning:	Accuracy: $x,y,z = 0.5\text{mm}$		
	Reproducibility: $x,y,z = 0.25\text{mm}$		
Movement Range: (on a STAR 8/iSWAP Instrument)	Minimum Absolute Position	Maximum Absolute Position	Remarks
x	-206mm	+1578mm	at x_{\min} 58mm space between microplate and deck at x_{\max} half plate on the deck
y	-185mm	+605mm	
z	+100mm +0mm	+282mm +282mm	: iSWAP 182600 rev. 00 – 02 : iSWAP 182600 rev. 03 and iSWAP Landscape 190220
Gripper Opening:	72mm 72mm	108mm 132mm	: iSWAP 182600 rev. 00 – 03 : iSWAP Landscape 190220
Gripping Force:	5 N – 16 N (default 9 N) 5 N – 16 N (default 9 N)		: iSWAP 182600 rev. 00 – 03 : iSWAP Landscape 190220
Transport Mass:	300g		filled Deep Well Plate
No restriction of random access range for 4-, 8-, 12-, and 16-pipetting channel on ML STAR.			
Operating Data:	Temperature Range:		15°C – 35°C
	Relative Humidity:		30% – 85% (non-condensing, indoors)
	Altitude:		Maximum 2000 meters above sea level
Maximum Modules per System	1 iSWAP per System		

7.17 Tube Gripper Specifications

Tube Sizes:	Tube diameter from 8mm to 20mm Tube height \leq 120mm		
Modal Precision:	x-, y-, z- positional accuracy of 0.1mm (measured on tube-gripper)		
Movement Range:			
x	Reaches the same X-coordinate as the single pipetting channels (e.g. on a STAR 8x 1000 μ l-pipetting channel instruments)		
y	Reaches all tube positions of the sample carriers: SMP-CAR-32 and SMP-CAR-24 (on a ML STAR instrument with 6x 1000 μ l-pipetting channels)		
z	Minimum Absolute Position	Maximum Absolute Position	Remarks
	+54.2mm	+254.2mm	Measured from the deck work surface to the gripping point on a tube
Gripper Opening:	Minimum Absolute Position	Maximum Absolute Position	
	5.5mm	22mm	
Transport Mass:	200g		
Operating Data:	Temperature Range:	15°C – 35°C	
	Relative Humidity:	30% – 85% (non-condensing, indoors)	
	Altitude:	Maximum 2000 meters above sea level	
Maximum Modules per System	1 Tube Gripper per System		

7.18 CO-RE Gripper 1000µl Specifications

Labware Format:	Microplate Footprint Plate Height ≤ 43mm		
Absolute Positioning:	Accuracy: x,y,z = 0.5mm		
	Reproducibility: x,y,z = 0.25mm		
Movement Range:			
	x	Track 1 – n (depending on instrument type)	
	y	Depending on # of pipetting channels and used front channel	
	z	Lowest position = 15mm over the deck work surface	
Gripper Opening:	Minimum Opening	Maximum Opening	Arm
	9mm	Dependent upon the travel range on the pipetting arm	Modular pipetting arm
	18mm	Dependent upon the travel range on the pipetting arm	Pipetting arm MPH/iSWAP, iSWAP arm
Gripping Force:	5 N – 16 N (default 9 N)		
Transport Mass:	300g filled Deep Well Plate		
Maximum Modules per System	2 Channels per System		

7.19 CO-RE Gripper 5ml Specifications

Labware Format:	Microplate Footprint Plate Height \leq 43mm		
Absolute Positioning:	Accuracy x,y,z = 0.5mm		
	Reproducibility x,y,z = 0.25mm		
Movement Range:			
	x	Track 1 – n (depending on instrument type)	
	y	Depending on # of pipetting channels and used front channel	
	z	Lowest position = 46mm over the deck work surface	
Gripper Opening:	Minimum Opening	Maximum Opening	Arm Type
	18mm	Dependent upon the travel range on the pipetting arm	Modular pipetting arm
	36mm	Dependent upon the travel range on the pipetting arm	Pipetting arm MPH/iSWAP, iSWAP arm
Gripping Force:	5 N – 16 N (default 9 N)		
Transport Mass:	300g filled deep well plate		
Maximum Modules per System	2 Channels per System		

7.20 Hamilton SBS Centrifuge Specifications

Features	Specifications
Dimensions	322mm x 352mm x 280mm
Weight	19.7kg
Input Voltage	48 VDC
Input Current (maximum)	7 A
Maximum Relative Centrifugal Force (rcf)	2,000 xg
Maximum Revolutions per Minute	4,200 rpm
Acceleration Time to Full Speed	Approximately 50 seconds
Maximum Load	2 x 500g
Maximum Load Height	60mm
Maximum Imbalance	6g at maximum rpm
Number of Buckets	2
Positioning Tolerance	± 1 degree (accuracy) ± 0.5 degree (precision)
Rotor Diameter	
Operating Conditions	Temperature: 15 – 35°C Relative Humidity: 15 – 85% (without condensation)
Lifetime	> 2,500 Hours
Imbalance Sensor	G-Force Sensor
Interface	CAN-Bus

7.21 48VDC Power Box Specifications

Features	Specifications
Dimensions	370mm x 100mm x 210mm
Weight	600g
Input Voltage	115 VAC / 230 VAC (± 10%)
Frequency	50/60 Hz
Maximum Power Consumption	480 VA
Primary Fuse	240 VAC: 4AT 250V 5x20 120 VAC: 10AT 250V 5x20
Secondary Fuse	10 AT 250V 5x20
Pollution Degree	2
Noise Level	<62dBA
Lifetime	6 years
Over-Voltage Category Specification	II

7.22 Hamilton Heater Shaker Specifications

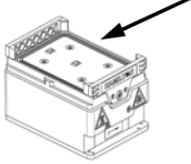
Instrument Dimensions:	Width (x)	Height (z)	Depth (y)		
	150mm	90mm	105mm		
Weight:	250 g				
Labware:	Standard microplates with adapter Standard Deep Well Plates with adapter Maximum weight (incl. adapter): 500g				
Temperature Specifications*:	Temperature	Ramp from 25°C	Deviation compared to the target temperature	Tolerance band for measurement and control: Deviation on plate (middle to edge position)	
	* Measured on top of the MTP flat bottom plate as shown below 	37°C 60°C 90°C 100°C 105°C	in 3 min in 10 min in 20 min in 30 min in 35 min	36.0°- 38.0°C 58.5°- 61.5°C 88.0°- 92.0°C 97.5°- 102.5°C 102.5°- 107.5°C	35.0°- 39.0°C 57.0°- 63.0°C 86.0°- 94.0°C 95.0°- 105.0°C 100°- 110°C
Features of the Heater Shaker¹:	Temperature Control:		From 5°C above ambient temperature to 105°C Controlled by two sensors (located in the middle and at the edge of the adapter plate)		
	Shaking Directions:		Clockwise and counter-clockwise		
	Acceleration:		2.0 seconds (from 0 to Maximum RPM)		
	Deceleration:		2.0 seconds (from Maximum RPM to 0)		
	Shaking Orbits: (peak to peak)		1.5mm 2.0mm 3.0mm		
	Recommended shaking speed in rpm's depending on Labware and shaking orbit				
	Orbit	MTP	DWP	Sarstedt	Customized
	1.5mm	Not available	2000	1800	Not available
	2.0mm	2500	2000	Not available	2000
	3.0mm	2400	1800	Not available	1800

Operating Data:	Power Consumption:	41 V / 140 W (maximum) supplied by ML STAR instrument or HSB
	Installation Category:	II
	Pollution Degree:	2
	Temperature Range:	15°C – 35°C
	Relative Humidity:	15% - 85%
	Noise Level:	< 65 dBA at maximum speed
	Altitude:	Maximum 2000 m above sea level
	Lifetime:	6 years
	Indoor Use Only	
Storage and Transportation:	Temperature Range:	-25°C - +70°C
	Relative Humidity:	10% - 90% (non-condensing)
Communication:	CAN via TCC connector or USB	

¹ The Hamilton Heater Shaker can always be adjusted from 100 to 2500 rpm independent of the version

7.23 Hamilton Heater Shaker Box (HSB) Specifications

Instrument Dimensions:	Width (x)	Height (z)	Depth (y)
	270mm	90mm	210mm
Weight:	2500g		
Operating Data:	Voltage:	115 VAC / 230 VAC (± 10%)	
	Frequency:	50/60 Hz	
	Power Consumption:	1000 VA (maximum)	
	Installation Category:	II	
	Pollution Degree:	2	
	Temperature Range:	15°C – 35°C	
	Relative Humidity:	15% - 85%	
	Noise Level:	< 65 dBA	
	Altitude:	Maximum 2000 meters above sea level	
	Lifetime:	6 years	
	Indoor Use Only		
Storage and Transportation:	Temperature Range:	-25°C - +70°C	
	Relative Humidity:	10% - 90% (non-condensing)	
HHS Connectors:	8		

7.24 Crystal Vacuum System (CVS) Specifications

CVS Carrier Dimensions:	Width (x)	Height (z)	Depth (y)
	155mm	112mm	555mm
Vacuum Pump Dimensions:	Width (x)	Height (z)	Depth (y)
	242mm	245mm	257mm
Waste Container:	Diameter: 155mm		Height: 380mm
Weight of CVS:	4kg		
Weight of Vacuum Pump:	13.5kg		
Operating Data:	Maximum Power Consumption:	530 W (230 VAC)	
	Voltage:	115 VAC / 230 VAC ($\pm 10\%$)	
	Frequency:	50/60 Hz	
	Temperature Range:	10°C – 40°C	
	Relative Humidity:	30% - 85%	
	Maximum HHS Shaker Speed:	2000 rpm	

7.25 Temperature Controlled Carrier (TCC) Specifications

TCC Dimensions:	Width (x)	Height (z)	Depth (y)
	132mm	120mm	555mm
External Heat Exchanger Dimensions:	Width (x)	Height (z)	Depth (y)
	400mm	220mm	500mm
Operating Data:	Maximum Power Consumption:	120 VA	
	Voltage:	41 VDC	
	Temperature Range:	Ambient minus 22°C to 60°C $\pm 2^\circ\text{C}$	
	Minimal Temperature:	4°C	
	Temperature Accuracy:	$\pm 2^\circ\text{C}$	

7.26 Multiflex Heating Module Specifications

Dimensions (without carrier base):	Width (x)	Height (z)	Depth (y)
	135mm	120mm	190mm
Weight:	0.5kg		
Operating Data:	Maximum Power Consumption:	50 W	
	Voltage:	41 VDC	
	Temperature Range:	Ambient plus 5°C to 65°C	
	Temperature Accuracy at 30°C – 65°C	< -0.5/+1.5°C	
	Temperature Accuracy	± 1°C	

7.27 Multiflex Cooling Module Specifications

Dimensions (without carrier base):	Width (x)	Height (z)	Depth (y)
	135mm	120mm	190mm
Weight:	1.2kg		
Operating Data:	Maximum Power Consumption:	50 W	
	Voltage:	41 VDC	
	Temperature Range:	15°C to 0°C	
	Temperature Accuracy:	± 1°C	

7.28 Multiflex Cooling-Heating Module Specifications

Instrument Dimensions:	Width (x)	Height (z)	Depth (y)	
	152mm	122mm	186mm	
Weight:	1200g			
Labware:	Standard microplates with adapter Standard PCR microplates with adapter Standard Deep well microplates with adapter			
Temperature Specifications*:	Temperature	Ramp from 22°C	Deviation compared to target temperature	Tolerance band for measurement and control: Deviation on microplate (middle to edge position)
	4°C	in 40 min	2.5°-5.5°C	1.0°-7.0°C
	37°C	in 7 min	36.0°-38.0°C	35.0°-39.0°C
	60°C	in 15 min	58.5°-61.5°C	57.0°-63.0°C
	95°C	in 30 min	93.0°-97.0°C	91.0°-99.0°C
Features of the Cooling-Heating Module:	Temperature Control: Heating		From 4°C to 95°C Controlled by two sensors	
	Temperature Control: Cooling		Maximum temperature deviation to ambient temperature is 20°C (i.e. if ambient temperature is 30°C, the cooling temperature can be minimum 10°C).	
Operating Data:	Voltage:		41 VDC	
	Power Consumption:		117W	
	Temperature Range:		15°C – 35°C	
	Relative Humidity:		15% - 85%	
	Noise Level:		<65 dBA	
	Altitude:		Maximum 2000 meters above sea level	
	Lifetime:		7 years	
	Indoor Use Only			
Storage and Transportation:	Temperature Range:		-25°C - +70°C	
	Relative Humidity:		10% - 90% (non-condensing)	

7.29 Tube Twister Channel and Decapper Module Specifications

Tube Twister Channel	Supported tube sizes	Vial diameters: from 15 to 38mm Vial height: from 50 to 120mm
	Transport area and positioning	The complete instrument work area, with limited access depending on instrument configuration. Maximal 4 channels. Minimal grip height 50mm above deck Positioning X/Y/Z : $\leq \pm 0.35\text{mm}$
	Mixing (twisting)	From 0 to 1500rpm $\pm 5\%$
	Barcode reading	As defined in Section 7.29.4 Sample Barcodes Additional feature: Align barcode
	Transport Mass 50ml Falcon tubes	50g contents (+tube weight)

Additional features for the Tube Twister Channel in combination with a Decapper Module:

Tube Twister Channel / Decapper Module	De-capping / Recapping	De-capping / recapping of screw top vials
	Decapper Module Small: Supported Tube Sizes with:	Vial diameters: from 15 to 27mm Cap diameters: from 18 to 32mm Vial height: from 50 to 120mm (including cap)
	Decapper Module Large: Supported Tube Sizes with:	Vial diameters: from 27 to 38mm Cap diameters: from 32 to 44mm Vial height: from 50 to 120mm (including cap)
Maximum Modules per System	2 or 4 Twister Channels per System No more and no less, all 2 or 4 channels are on separate iSWAP Arm, no combination with other components on the same arm.	

7.30 Autoload Option: Barcode and Reader Specifications

Carriers, containers, racks and tip racks can be identified by a barcode, which a reader, mounted on the Autoload slide, scans. The system must allow specification of ranges (barcode mask) for plausibility checking of barcode information.

7.30.1 Barcode Symbologies

The following barcode symbologies can be detected by the system:

- ISBT standard
- Code 128 (subset B and C)
- Code 39
- Codabar
- Code 2 of 5 Interleaved
- UPC A/E
- JAN/EAN 8

For the highest reading safety Hamilton recommends:

1. To use barcode type Code128 (subset B and C).
2. Disabling the unused barcode types in the configuration editor of the User Software (refer to the [Microlab STAR Programmer's Manual](#)).
3. Defining a barcode mask via the Labware Editor of the User Software (refer to the [Microlab STAR Programmer's Manual](#)).

7.30.2 Reading Accuracy

The rate of inaccurate readings of sample plates and container bar codes is less than 1 ppm.

The above mentioned specification are valid under the following conditions:

- Barcode Symbology Module: ISBT standard
- Code Density: 0.0065" (0.1651mm)
- Print Quality see [Section 7.29.3 Barcode Specifications](#)
- Recognized errors are defined as an accurate reading

7.30.3 Barcode Specifications

Type:	Black bars and white background	
Length of String:	Maximum 20 characters excluding start, stop and check characters, depending on the barcode length (see label dimensions).	
Code Density, Tolerance:	Minimum module width (x dimension) including a print tolerance: $\geq 0.0065''$ (0.1651mm) Maximum module width (x dimension) including a print tolerance: $\leq 0.02''$ (0.508mm) Best reading performance with x dimension $\geq 0.01''$ (0.254mm)	
Check Character:	ISBT Standard	One character
	Code 128	One character
	Code 39	None
	Codabar	None
	Code 2 of 5 Interleaved	None
	UPC A/E	One character
Quiet Zone:	≥ 10 Times the x dimension, but at least 3mm	
Print Quality:	The barcode print must be of a high quality. A printed barcode with an ANSI/ CEN/ ISO grade A or B is required. Offset, typographic, intaglio and flexographic printing are suitable. Mechanical dot matrix and thermos matrix printing are <u>not</u> suitable. The surface may be treated, sealed or plastic-coated.	

7.30.4 Sample Barcodes

Barcode Specifications:

For General Barcode Specifications, see [Section 7.29.3 Barcode Specifications](#).

Dimension		Minimum	Maximum
A	Label length	-	80mm
B	Code length	-	74mm
C	Quiet zone	3mm	
D	Label width	12mm	-
E	Code width	12mm	-
F	Distance from the barcode to the label edge	-	1mm

Positioning Barcode Labels:

The label must be glued within a range of between 20mm to 100mm from the bottom of the tube.
 The label must fit tightly at an angle of 90° to the tube.

The label must fit tightly over its entire length.

7.30.5 Reagent Barcodes

<p>Proposed Barcode Mask: RGT_mm</p>	<p>RGT: Reagent _: Separator (underline) mm: Reagent number 1.....99</p>		
<p>Label Specification:</p> <p>For General Barcode Specifications, see Section 7.29.3 Barcode Specifications.</p>			
	Dimension	Minimum	Maximum
A	Label length	-	66mm
B	Code length	-	60mm
C	Quiet zone	3mm	-
D	Label width	15mm	-
E	Code width	12mm	-
F	Distance from barcode to the edge of the label	-	1mm

Positioning of the Barcode Labels:

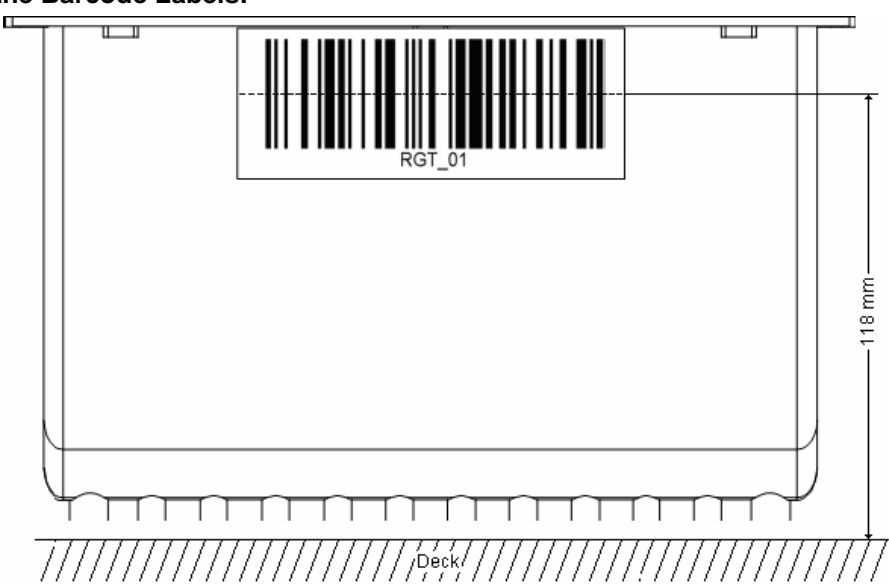

The label must be positioned on the upper edge, in the middle of the container.
The label must fit tightly over its entire length.

Positioning of the Barcode Label on a 50 ml Reagent Trough:

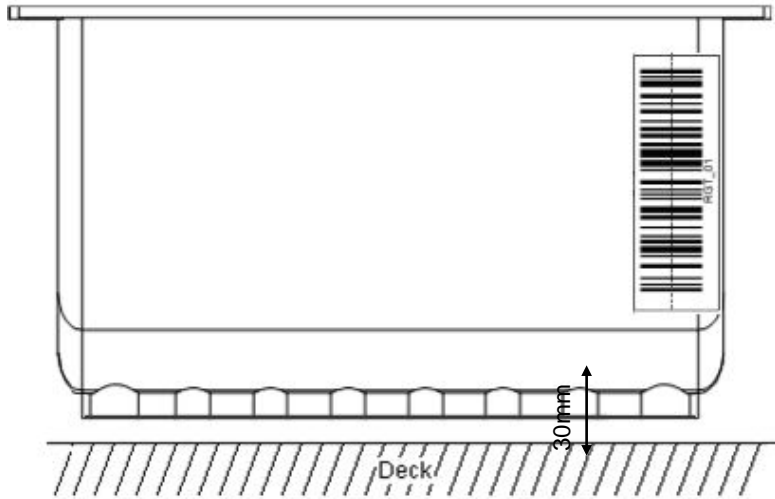

The label must be glued within a range between 30mm to 110mm from the deck.

7.30.6 Plate Barcodes

Label Specifications:

For General Barcode Specifications, see [Section 7.29.3 Barcode Specifications](#).

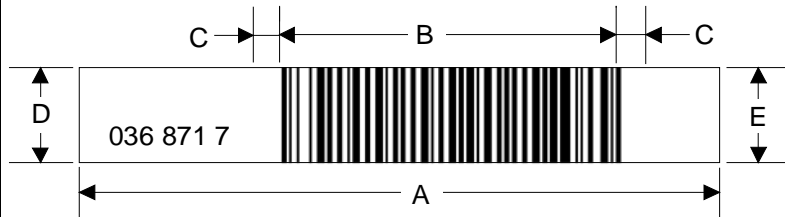

Dimension		Minimum	Maximum
A	Label length	-	66mm
B	Code length	-	30mm
C	Quiet zone	3mm	-
D	Label width	10mm	-
E	Code width	7mm	-
	Distance from the barcode to the label edge (if necessary)	-	1mm

Positioning Barcode Labels:

The plate barcode must fit on side A or side B of the plate.

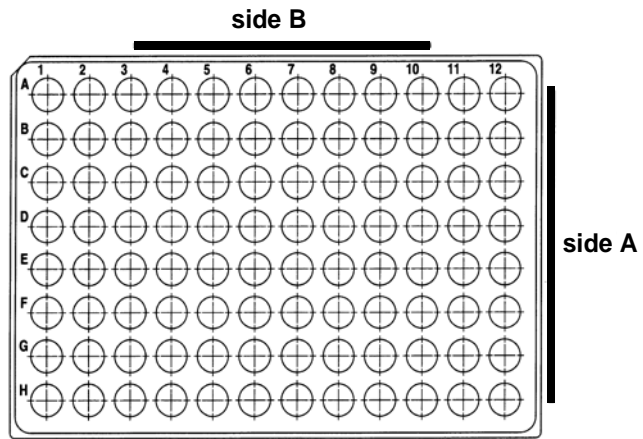

The barcode labels must be positioned in the middle of the plate.

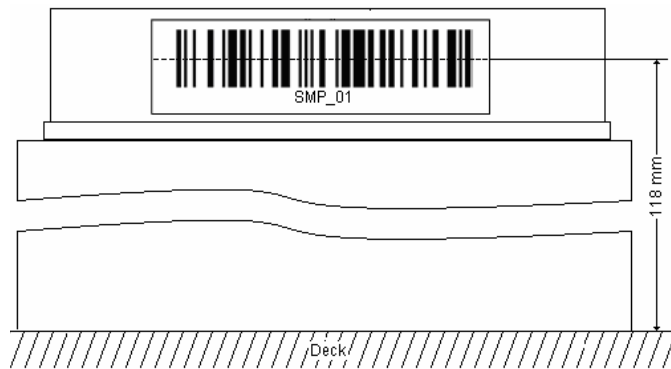

The barcode label must be centered and parallel to the edge of the plate.

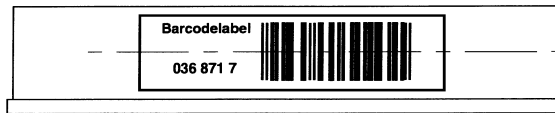

The barcode label must not protrude above or below the edge of the plate.



8. Appendices

8.1 Appendix A: Chemical Compatibility

8.1.1 Abbreviations of Metals and Polymers Used in the Following Tables

1.4310	X10CrNi18-8 steel	PE	Polyethylene
1.4435	X2CrNiMo18-14-3 steel	PEEK	Polyetheretherketone
AA 5083 0	Aluminum	PMMA	Polymethyl-methacrylate
EPDM	Ethylene-propylene-elastomer	POM	Polyoxymethylene
FPM	Fluoroelastomer	PP	Polypropylene
FFKM	Kalrez	PTFE	Polytetrafluorethylene
FFPM	Per-Fluor-elastomer	PVC	Polyvinylchloride
FKM	Viton	PVDF	Polyvinylidene fluoride
NBR	Acrylonitril-butadiene-rubber	SI	Silicone

The tables for chemical compatibility are based on information from different manufacturers. The results refer to laboratory tests with raw materials. The results with these materials are often associated with effects that cannot be observed under laboratory conditions (e.g. temperature, pressure, tension, chemical influences of substances, design features, etc.). The results listed may be considered only as a guideline. In case of doubt we recommend significant tests. The chemical resistance is not sufficient for an evaluation of a particular material for a product. Particular regulations (e.g. explosion prevention in the case of flammable liquids) have to be taken into account.

8.1.2 Chemical Resistance of the Multi-Probe Heads

Chemical	Materials													Overall resistance		
	1.4034	1.4301	1.4305	1.4404	1.4435	PE	PP	PTFE	PEEK	FKM	FFKM	EPT	ZrO ₂	CO-RE	96	384
Acetic acid, 20%	2	1	1	1	1	1	1	1	1	2	1	1	0	1	1	2
Acetic acid, glacial	2	1	1	1	1	1	1	1	1	4	1	1	0	1	1	4
Acetone	1	1	1	1	1	2	1	1	1	4	1	1	0	1	1	4
Acetonitrile	1	1	1	1	1	1	3	1	0	2	0	3	0	3	3	2
Ammonium hydroxide, 5%	1	1	1	1	1	1	1	1	1	1	1	1	0	1	1	1
Chloroform	1	1	1	1	1	3	3	1	1	1	1	4	0	4	4	1
Deionized water	1	1	1	1	1	1	1	1	1	1	1	1	0	1	1	1
Dimethyl formamide	1	1	1	1	1	1	1	1	1	3	1	1	0	1	1	3
Dimethyl sulfoxide	1	1	1	1	1	1	1	1	0	0	0	1	0	1	1	1
Ethyl acetate	1	1	1	1	1	2	1	1	1	4	1	1	0	1	1	4
Hexane	1	1	1	1	1	3	2	1	1	1	1	4	0	4	4	1
Hydrochloric acid, 5%	4L	2L	3L	2L	2L	1	1	1	1	1	1	1	1	1	1	1
Hydrochloric acid, 20%	4L	3L	3L	2L	2L	1	1	1	1	1	1	1	1	1	1	1
Hydrogen peroxide, 10%	1	1	1	1	1	2	2	1	1	2	2	2	1	2	2	2
Isopropyl alcohol	1	1	1	1	1	1	1	1	1	1	1	1	0	1	1	1
Methanol	1	1	1	1	1	1	1	1	1	2	1	1	0	1	1	2
Methylene chloride	1	1	1	1	1	4	3	1	2	2	1	4	0	4	4	2
Nitric acid, 5-10%	1	1	1	1	1	1	1	1	1	1	1	3	1	3	3	1
Nitric acid, 70%	1	1	1	1	1	3	4	1	1	2	1	3	1	3	3	2
Phosphate buffer	1	1	1	1	1	1	1	1	0	1	1	1	0	1	1	1
Phosphoric acid, 85%	3	2	3	2	2	1	1	1	0	1	1	1	1	3	3	2
Potassium hydroxide conc.	3	1	2	1	1	1	1	1	1	3	1	1	1	2	2	3
Sodium acetate	1	1	1	1	1	1	1	1	0	4	1	1	0	1	1	4
Sodium borate	1	1	1	1	1	1	1	1	0	1	1	1	0	1	1	1
Sulfuric acid, 1-75%	4	2	3	2	2	1	1	1	2	1	1	1	1	3	3	2
Urine	1	1	1	1	1	1	1	1	1	1	1	1	0	1	1	1
Triethylamine	1	1	1	1	1	0	4	1	0	4	0	4	0	4	4	4
Toluene	1	1	1	1	1	3	3	1	1	1	1	4	0	4	4	1
Sodium hydroxide 5%	1	1	1	1	1	1	1	1	1	1	1	1	1	1	1	1
Formic acid 5%	3	1	2	1	1	1	1	1	1	2	1	1	0	2	2	2
Sodium hypochloride 10%	3L	2L	2L	1L	1L	1	1	1	0	1	1	1	0	1	1	1
Ethanol	1	1	1	1	1	1	1	1	1	1	1	1	0	1	1	1

Effects (key to codes in the table above):

- 1 = No effect, little or no noticeable change
- 2 = Slight corrosion or discoloration
- 3 = Moderate corrosion or other change in physical properties or dimensions; not recommended for continuous contact
- 4 = Severe corrosion or physical change; prolonged contact not recommended
- 0 = No data
- L = Danger of pitting / corrosion (a localized form of corrosion that leads to the creation of small holes in the metal)

Assigned Materials

- CO-RE Head consist of 1.4305, EPDM, PEEK, ZrO₂ and PTFE
- 96 Head consist of 1.4305, EPDM, PEEK, ZrO₂ and PTFE
- 384 Head consist of 1.4435, Viton and ZrO₂

8.1.3 Chemical Resistance of the CR Needle Wash Station

Chemical	1.4435	1.4310	AA 5083 0	FFKM	PE	PTFE	PEEK	PP	FFPM	Over all resistance
Acetic acid, 20%	1	1	2	1	1	1	1	1	1	1
Acetic acid, glacial	1	1	2	4	1	1	1	1	1	1
Acetone	1	1	1	1	2	1	1	1	1	2
Acetonitrile	1	1	0	0	1	1	0	3	0	(3)
Ammonium hydroxide, 5%	1	1	0	0	1	1	1	1	1	1
Chloroform	1	1	1	1	3	1	1	3	1	3
Deionized water ²	1	1	1	1	1	1	1	1	1	1
Dimethyl formamide	1	1	0	1	1	1	1	1	1	1
Dimethyl sulfoxide max. 30%	1	1	0	1	1	1	0	1	0	1
Ethyl acetate	1	1	0	1	2	1	1	1	1	2
Hexane	1	1	1	1	3	1	1	2	1	3
Hydrochloric acid, 20%	2L	2L	2	1	1	1	1	1	1	4
Isopropyl alcohol	1	1	1	1	1	1	1	1	1	1
Methanol	1	1	1	1	1	1	1	1	1	1
Methylene chloride	1	1	1	1	4	1	2	3	1	4
Nitric acid, 5-10%	1	1	2	1	1	1	1	1	1	1
Nitric acid, 70%	1	1	2	1	3	1	1	4	1	4
Phosphate buffer	1	1	0	1	1	1	0	1	1	(1)
Phosphoric acid, 85%	2	2	0	1	1	1	0	1	1	(2)
Potassium hydroxide conc.	1	1	4	1	1	1	1	1	1	1
Sodium acetate	1	1	0	1	1	1	0	1	1	(1)
Sodium borate	1	1	0	1	1	1	0	1	1	(1)
Sulfuric acid, 1-75%	1L	2L	0	1	1	1	0	1	0	2
Urine	2	2	3	1	1	1	2	1	1	1
Triethylamine	1	1	0	1	0	1	1	1	1	4
Toluene	1	1	0	0	3	1	0	4	0	3

Effects (key to codes in above table):

- 1 = No effect, little or no noticeable change
- 2 = Slight corrosion or discoloration
- 3 = Moderate corrosion or other change in physical properties or dimensions; not recommended for continuous contact
- 4 = Severe corrosion or physical change; prolonged contact not recommended
- 0 = No data
- L = Danger of pitting / corrosion (a localized form of corrosion that leads to the creation of small holes in the metal)

8.1.4 Chemical Resistance of the Wash Station

Chemical	1.4310	PE	PTFE	PEEK	PP	PVDF	FPM	SI	PVC	EPDM	NBR	POM
Acetic acid, 20%	1	1	1	1	1	1	3	2	1	2	3	1
Acetic acid, glacial	1	1	1	1	1	1	4	2	4	4	4	4
Acetone	1	2	1	1	1	3	4	3	0	1	4	1
Acetonitrile	1	1	1	0	3	1	3	0	0	3	4	3
Ammonium hydroxide, 5%	1	1	1	1	1	2	2	1	0	1	2	1
Chloroform	1	3	1	1	3	1	3	4	4	4	4	4
Deionized water ²⁾	1	1	1	1	1	1	1	1	1	1	1	1
Dimethyl formamide	1	1	1	1	1	4	4	2	4	2	4	1
Dimethyl sulfoxide max. 30%	1	1	1	0	1	3	3	0	4	3	4	1
Ethyl acetate	1	2	1	1	1	3	4	2	4	3	4	1
Hexane	1	3	1	1	2	1	1	4	4	4	1	1
Hydrochloric acid, 20%	4	1	1	1	1	1	1	3	1	1	4	4
Isopropyl alcohol	1	1	1	1	1	1	1	1	4	1	3	1
Methanol	1	1	1	1	1	1	3	1	3	1	3	1
Methylene chloride	1	4	1	2	3	1	3	4	4	4	4	3
Nitric acid, 5-10%	1	1	1	1	1	1	1	2	1	2	4	4
Nitric acid, 70%	1	3	1	1	4	1	2	4	4	4	4	4
Phosphate buffer	1	1	1	0	1	1	1	4	0	1	1	1
Phosphoric acid, 85%	2	1	1	0	1	1	1	3	1	3	4	4
Potassium hydroxide conc.	1	1	1	1	1	2	4	3	0	1	3	3
Sodium acetate	1	1	1	0	1	1	3	4	3	1	3	1
Sodium borate	1	1	1	0	1	1	1	1	1	1	3	1
Sulfuric acid, 1-75%	2	1	1	2	1	1	1	3	1	4	4	4
Urine	1	1	1	1	1	1	1	1	1	1	1	1
Triethylamine	1	0	1	0	4	3	3	4	0	4	3	1
Toluene	1	3	1	1	3	1	1	4	4	4	4	1

Effects (key to codes in above table):

- 1 = No effect, little or no noticeable change
- 2 = Slight corrosion or discoloration
- 3 = Moderate corrosion or other change in physical properties or dimensions; not recommended for continuous contact
- 4 = Severe corrosion or physical change; prolonged contact not recommended
- 0 = No data

8.1.5 Chemical Resistance of the 96/384 Wash Station

Chemical	1.4310	PE	PP	PTFE	PEEK	FFPM	Hypalon	Over all resistance
Acetic acid, 20%	1	1	1	1	1	1	2	2
Acetic acid, glacial	1	1	1	1	1	1	3	3
Acetone	1	2	1	1	1	1	3	3
Acetonitrile	1	1	3	1	0	0	0	(3)
Ammonium hydroxide, 5%	1	1	1	1	1	1	3	3
Chloroform	1	3	3	1	1	1	4	4
Deionized water	1	1	1	1	1	1	1	1
Dimethyl formamide	1	1	1	1	1	1	3	3
Dimethyl sulfoxide, max. 30%	1	1	1	1	0	0	0	(1)
Ethyl acetate	1	2	1	1	1	1	4	4
Hexane	1	3	2	1	1	1	2	3
Hydrochloric acid, 20%	4	1	1	1	1	1	2	4
Isopropyl alcohol	1	1	1	1	1	1	1	1
Methanol	1	1	1	1	1	1	1	1
Methylene chloride	1	4	3	1	2	1	4	4
Nitric acid, 5-10%	1	1	1	1	1	1	2	2
Nitric acid, 70%	1	3	4	1	1	1	4	4
Phosphate buffer	1	1	1	1	0	1	1	(1)
Phosphoric acid, 85%	2	1	1	1	0	1	2	(2)
Potassium hydroxide conc.	1	1	1	1	1	1	2	2
Sodium acetate	1	1	1	1	0	1	2	(2)
Sodium borate	1	1	1	1	0	1	1	(1)
Sulfuric acid, 1-75%	2	1	1	1	2	1	2	2
Urine	1	1	1	1	1	1	1	1
Triethylamine	1	0	4	1	0	0	3	4
Toluene	1	3	3	1	1	1	1	3

Effects (key to codes in above table):

- 1 = No effect, little or no noticeable change
- 2 = Slight corrosion or discoloration
- 3 = Moderate corrosion or other change in physical properties or dimensions; not recommended for continuous contact
- 4 = Severe corrosion or physical change; prolonged contact not recommended
- 0 = No data

8.1.6 Chemical Resistance of the CVS

Chemical	PE	PP	PVDF	PMMA	AA6023 TTG	Remarks
N-Hexan	2/3	2/3	1/1	(3)	1/1	flammable
Ethyl-Acetate	1/3	1/3	3/3	0	1/1	flammable
Methanol	1/1	1/1	1/1	(3)	1/0	flammable
Acetonitrile (100%)	1/1	3/4	1/1	(3/4)	(1)	flammable
Methylene Chloride	0/0	(3)	(2)	(3)	1/1	flammable
Formic Acid (0.1%)	1/1	1/2	1/1	(3)	(3)	
Ammonia (0.1%)	1/1	1/1	(2)	2/2	1/1	

*PMMA may cause stains to the labware.

Resistance:

Two values are given for each medium:

left number = value at +20°C / right number = value at +50°C.



Effects (key to codes in above table):

- 0 = No data available / no statement possible
- 1 = Very stable / suitable
- 2 = Good resistance / suitable
- 3 = Partially resistant
- 4 = Not resistant
- K = No general specifications possible
- L = Danger of pitting / corrosion
- () = Estimated



8.2 Appendix B: Ordering Information

8.2.1 Standard Tips



8.2.1.1 50µl Standard Tips

50µl Standard Tips (1.0µl – 50µl)		
Part Number	Description	Image
235966	50µl CO-RE tips without filter 1.0 – 50µl Conductive Case of 5760 tips (blister pack)	
235948	50µl CO-RE tips with filter 1.0 – 50µl Conductive Case of 5760 tips (blister pack)	
235978	50µl CO-RE tips without filter 1.0 – 50µl Conductive, sterilized Case of 5760 tips (blister pack)	
235979	50µl CO-RE tips with filter 1.0 – 50µl Conductive, sterilized Case of 5760 tips (blister pack)	
235829	50µl CO-RE tips without filter 1.0 – 50µl Clear tip Case of 5760 tips (blister pack)	
235831	50µl CO-RE tips without filter 1.0 – 50µl Clear tip, sterilized Case of 5760 tips (blister pack)	
235836	50µl CO-RE tips without filter 1.0 – 50µl Clear tip Case of 5760 tips (blister pack)	
235837	50µl CO-RE tips without filter 1.0 – 50µl Clear tip, sterilized Case of 5760 tips (blister pack)	
235964	50µl CO-RE tips without filter 1.0 – 50µl Clear tip Case of 11520 tips (NTR)	
235947	50µl CO-RE tips without filter 1.0 – 50µl Conductive Case of 11520 tips (NTR)	
235987	50µl CO-RE tips without filter 1.0 – 50µl Conductive, sterilized Case of 11520 tips (NTR)	

8.2.1.2 300µl Standard Tips

300µl Standard Tips (10µl – 300µl)		
Part Number	Description	Image
235902	Standard CO-RE tips without filter 10 – 300µl Conductive Case of 5760 tips (blister pack)	
235937	Standard CO-RE tips without filter 10 – 300µl Conductive, sterilized Case of 5760 tips (blister pack)	
235985	Standard CO-RE tips without filter 10 – 300µl Conductive, sterilized Case of 11520 tips (NTR)	
235950	Standard CO-RE tips without filter 10 – 300µl Conductive Case of 11520 tips (NTR)	
235830	Standard CO-RE tips without filter 10 – 300µl Clear tip Case of 5760 tips (blister pack)	
235832	Standard CO-RE tips without filter 10 – 300µl Clear tip, sterilized Case of 5760 tips (blister pack)	
235834	Standard CO-RE tips without filter 10 – 300µl Clear tip Case of 5760 tips (blister pack)	
235835	Standard CO-RE tips without filter 10 – 300µl Clear tip, sterilized Case of 5760 tips (blister pack)	
235965	Standard CO-RE tips without filter 10 – 300µl Clear tip Case of 11520 tips (NTR)	
235938	Standard CO-RE tips with filter 10 – 300µl Conductive, sterilized Case of 5760 tips (blister pack)	
235903	Standard CO-RE tips with filter 10 – 300µl Conductive Case of 5760 tips (blister pack)	





8.2.1.3 1000µl Standard Tips

1000µl Standard Tips (10 µl – 1000µl)		
Part Number	Description	Image
235904	High CO-RE tips without filter 10 – 1000µl Conductive Case of 3840 tips (blister pack)	
235939	High CO-RE tips without filter 10 – 1000µl Conductive, sterilized Case of 3840 tips (blister pack)	
235905	High CO-RE tips with filter 10 – 1000µl Conductive Case of 3840 tips (blister pack)	
235940	High CO-RE tips with filter 10 – 1000µl Conductive, sterilized Case of 3840 tips (blister pack)	
235820	High CO-RE tip without filter 10 – 1000µl Clear Case of 3840 tips (blister pack)	
235821	High CO-RE tip without filter 10 – 1000µl Clear, sterilized Case of 3840 tips (blister pack)	
235822	High CO-RE tip without filter 10 – 1000µl Clear Case of 3840 tips (blister pack)	
235823	High CO-RE tip without filter 10 – 1000µl Clear, sterilized Case of 3840 tips (blister pack)	





8.2.1.4 5ml Standard Tips

5ml Standard Tips (50µl – 5000µl / (4000µl with filter))		
Part Number	Description	Image
184020	5ml CO-RE tips without filter 50 – 5000µl Conductive Case of 720 tips (blister pack)	
184022	5ml CO-RE tips without filter 50 – 5000µl Conductive, sterilized, Case of 720 tips (blister pack)	
194050	5ml CO-RE tips without filter 50 – 5000µl Conductive Case of 96 tips, 4 tips individually wrapped (blister pack)	
184021	5ml CO-RE tip with filter 50 – 4000µl Conductive Case of 720 tips (blister pack)	
184023	5ml CO-RE tip with filter 50 – 4000µl Conductive, sterilized Case of 720 tips (blister pack)	
194053	4ml CO-RE tip with filter 50 – 4000µl Conductive Case of 96 tips, 4 tips individually wrapped (blister pack)	

8.2.2 Steel Needles for 1000µl Single Channels

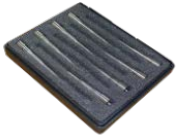
Steel Needles for 1000µl Single Channels		
Part Number	Description	Image
235930	1000µL NEEDLE SET CR Set of 8x 1000µl needles, CR Wash Station	
235931	300µL NEEDLE SET CR Set of 8x 300µl needles, CR Wash Station	
235932	10µL NEEDLE SET CR Set of 8x 10µl needles, CR Wash Station	
187290	NEEDLE SERVICE KIT Contains a Needle pick-up tool to remove needles individually from the wash station.	

8.2.3 Teaching Needles

182136	SET OF 8 TEACHING NEEDLES Used for the maintenance to check the pressure tightness of the 1000µl pipetting-channels	
182176	TEACHING NEEDLE 1 needle for 1000µl-pipetting channels, used for labware teaching (Set of 8 P/N 182136)	
184184	TEACHING NEEDLE 1 needle for 5ml-pipetting channels, used for labware teaching	
187290	NEEDLE SERVICE KIT Contains a Needle pick-up tool to remove needles individually from the wash station.	

8.2.4 10µl Low Volume Tips

10µl Low Volume Tips (0.5µl – 10µl)		
Part Number	Description	Image
235900	10µl CO-RE tips without filter 0.5 – 10µl Conductive Case of 5760 tips (blister pack)	
235901	10µl CO-RE tips with filter 0.5 – 10µl Conductive Case of 5760 tips (blister pack)	
235935	10µl CO-RE tips without filter 0.5 – 10µl Conductive, sterilized Case of 5760 tips (blister pack)	
235936	10µl CO-RE tips with filter 0.5 – 10µl Conductive, sterilized Case of 5760 tips (blister pack)	
235949	10µl CO-RE tips without filter 0.5 – 10µl Conductive, in a Nested Tip Box Case of 11520 tips (NTR)	
235983	10µl CO-RE tips without filter 0.5 – 10µl Conductive, sterilized Case of 11520 tips (NTR)	

10µl Low Volume Tips (0.5µl – 10µl)		
Part Number	Description	Image
235971	10µl CO-RE tips without filter 0.5 – 10µl Clear tip Case of 11520 tips (NTR)	

8.2.5 50µl Standard Tips for CO-RE 384 Probe Head

50µl Standard Tips for CO-RE 384 Probe Head (0.5 µl – 50µl)		
Part Number	Description	Image
235989	384 Probe Head CO-RE tips 50µl without filter 0.5 – 50µl Conductive Case of 7680 tips, 384 tips per rack (NTR)	
235694	384 Probe Head CO-RE tips 50µl without filter 0.5 – 50µl Conductive, sterilized Case of 7680 tips, 384 tips per rack (NTR)	
235446	384 Probe Head CO-RE tips 50µl without filter 0.5 – 50µl Clear tips Case of 7680 tips, 384 tips per rack (NTR)	
235824	384 Probe Head CO-RE tips 50µl without filter 0.5 – 50µl Clear tips, sterilized Case of 7680 tips, 384 tips per rack (NTR)	
235993	96 Probe Head CO-RE tips 50µl without filter 0.5 – 50µl Conductive Case of 1920 tips, 96 tips per rack (NTR)	
235695	96 Probe Head CO-RE tips 50µl without filter 0.5 – 50µl Conductive, sterilized Case of 1920 tips, 96 tips per rack (NTR)	
235447	96 Probe Head CO-RE tips 50µl without filter 0.5 – 50µl Clear tips Case of 1920 tips, 96 tips per rack (NTR)	
235825	96 Probe Head CO-RE tips 50µl without filter 0.5 – 50µl Clear tips, sterilized Case of 1920 tips, 96 tips per rack (NTR)	

8.2.6 250µl Robotic Piercing Tips for CO-RE 96-Probe Heads

250µl Robotic Piercing Tips for CO-RE 96-Probe Heads (2.0µl – 250µl (150µl with filter))		
Part Number	Description	Image
235805	Robotic Piercing tips 250µl without filter 2.0 – 250µl Conductive Case of 3840 tips (blister pack)	
235659	Robotic Piercing tips 250µl without filter 2.0 – 250µl Conductive, sterilized Case of 3840 tips (blister pack)	
235658	Robotic Piercing tips 250µl with filter 2.0 – 150µl Conductive Case of 3840 tips (blister pack)	
235649	Robotic Piercing tips 250µl with filter 2.0 – 150µl Conductive, sterilized Case of 3840 tips (blister pack)	



8.2.7 300µl SPECIAL TIPS Extra-Long and Slim Tips

300µl SPECIAL TIPS Extra-Long and Slim Tips (10µl – 300µl)		
Part Number	Description	Image
235806	Extra long and slim tips 300µl without filter 10 – 300µl Conductive Case of 3840 tips (blister pack)	
235648	Extra long and Slim tips 300µl without filter 10 – 300µl Conductive, sterilized Case of 3840 tips (blister pack)	
235647	Extra long and Slim tips 300µl with filter 10 – 300µl Conductive Case of 3840 tips (blister pack)	
235646	Extra long and Slim tips 300µl with filter 10 – 300µl Conductive, sterilized Case of 3840 tips (blister pack)	

8.2.8 300µl Rocket Tips for CO-RE 384 Probe Head

Rocket Tips for CO-RE 384 Probe Head (300µl)		
Part Number	Description	Image
235974	300µl Rocket tips without filter Conductive, rack, containing 96 tips Case of 4800 tips (blister pack)	



8.2.9 300µl Wide Bore Tips





300µl Wide Bore Tips (10µl – 300µl)		
Part Number	Description	Image
235452	300µl Wide bore tips, 0.71mm orifice with filter 10 – 300µl Conductive Case of 5760 tips (blister pack)	
235688	300µl Wide bore tips, 0.71mm orifice without filter 10 – 300µl Conductive Case of 5760 tips (blister pack)	
235449	300µl Wide bore tips, 1.55mm orifice with filter 10 – 300µl Conductive Case of 5760 tips (blister pack)	
235451	300µl Wide bore tips, 1.55mm orifice without filter 10 – 300µl Conductive Case of 5760 tips (blister pack)	
235679	300µl HVT, 1.2mm without filter Conductive Case of 3840 tips (blister pack)	
235678	300µl HVT Sterile, 1.2mm with filter Conductive Case of 3840 tips (blister pack)	

8.2.10 1000µl Wide Bore HIGH Tips for CO-RE 96 Probe Head

1000µl Wide Bore HIGH Tips for CO-RE 96 Probe Head (10µl – 1000µl)		
Part Number	Description	Image
235444	1000µl Wide bore tips, 3.20mm orifice without filter 10 – 1000µl Conductive Case of 3840 tips (blister pack)	
235541	1000µl Wide bore tips, 3.20mm orifice with filter 10 – 1000µl Conductive, Sterilized Case of 3840 tips (blister pack)	

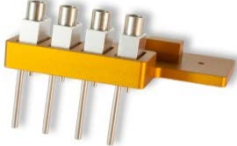
8.2.11 FlipTube System

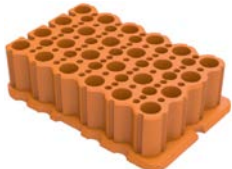
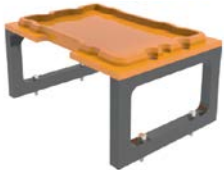



Reagent Tubes		
Part Number	Description	Image
235454	FLIPTUBES 1.5ml reagent tubes with a lid attached which can close the tube tightly.	
235692	FLIPTUBES PURITY TESTED 1.5ml reagent tubes with a lid attached which can close the tube tightly.	
235693	FLIPTUBES BIOLOGICAL PURITY PLUS 1.5ml reagent tubes with a lid attached which can close the tube tightly.	



809032	FLIPTUBE TOOL	
809306	FLIPTUBE TOOL PARK STATION ON WASTE	
199085	HAMILTON HEATER SHAKER 3 FOR FLIPTUBE RACK This HHS is equipped with a built-in adapter for a FlipTube Rack. Shaker orbit: 3mm Shaking speed: 100 – 1800/2400 rpm Temperature control: RT+5°C – 105°C	
814269	FLIPTUBE H/C BLOCK 24 position block for cooling/heating devices. It must be used with FlipTube Racks. This block is not compatible with the Hamilton Heater Shaker.	
814275	MULTIFLEX FLIPTUBE RACK PARK POSITION The Multiflex Rack Park Position is used for a correct alignment after the transport 24 position block for cooling/heating devices. It must be used with FlipTube Racks.	
814270	FLIPTUBE RACK The FlipTube Rack is a 24 position SBS format rack for handling and transport of Hamilton FlipTube A (P/N 235454, P/N 235692, P/N 235693) between different functional devices such as heaters, coolers, shakers, centrifuges and others. Set of 5 racks. Material: Polycarbonate.	
809030	SMP_CAR_32FT Sample Carrier for 32 FlipTubes (1T)	

8.2.12 Disposable Waste Bags





Disposable Waste Bags		
Part Number	Description	Image
199201	PLASTIC CHUTE "BIOHAZARD" WITH BIOHAZARD LABELING (roll of 10 pcs), 700 x 600mm, PE This chute is used with Waste Container (P/N 281520)	
199202	WASTE BAG WITHOUT BIOHAZARD LABELING (roll of 25 pcs), 460 x 500mm, PE	
199203	WASTE BAGS "BIOHAZARD" WITH BIOHAZARD LABELING (roll of 25 pcs), 460 x 500mm, PE	
185319	WASTE CHUTE WITHOUT BIOHAZARD LABELING (roll of 10 pcs), 460 x 700mm, PE This chute is used with Waste Container (P/N 281520)	
281520	WASTE CONTAINER "BIOHAZARD" (Pack of 10 boxes), combustible This container is used with Waste Chute (P/N 199201 and P/N 185319)	

8.2.13 Reagent Containers



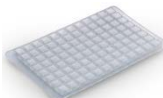

Reagent Containers		
Part Number	Description	Image
56694-01	REAGENT CONTAINER 60ml Set of 28 transparent, self-standing with lid, for carrier RGT_CAR_5R60 (194057 1T)	
56694-02	REAGENT CONTAINER 60ml Set of 28 transparent, self-standing with lid, for carrier RGT_CAR_5R60 (194057 1T)	
194051	REAGENT CONTAINER 60ml Set of 28 transparent, self-standing, barcodes included in box, w/o lid, individually wrapped for carrier RGT_CAR_5R60 (194057 1T)	
182703	REAGENT CONTAINER 120ml Set of 12 transparent for carrier RGT_CAR_3R (185290 1T)	

Reagent Containers		
Part Number	Description	Image
194052	REAGENT CONTAINER 120ml Set of 12 transparent, self-standing, barcodes included in box, 120ml for carrier RGT_CAR_3R (194058 1T)	
56695-01	REAGENT CONTAINER 200ml Set of 10 transparent, self-standing with lid, for carrier RGT_CAR_4R200 (185436)	
56695-02	REAGENT CONTAINER 200ml Set of 10, black, self-standing with lid, for carrier RGT_CAR_4R200 (185436)	

8.2.14 Deep Well Plates

Deep Well Plates		
Part Number	Description	Image
6471-01	DEEP WELL BLOCK 1.2ml, PP 96 well block, polypropylene, 1.2ml volume per well, round wells. W: 126.3mm; D: 84.7mm; H: 40.6mm 32 pcs/case, 4 plates are wrapped	
6472-01	DEEP WELL BLOCK 1.2ml, PS 96 well block, polystyrene, transparent, 1.2ml volume per well, round wells. W: 127.5mm; D: 85.5mm; H: 41mm 32 pcs/case, 4 plates are wrapped	
235655	DEEP WELL BLOCK 1.2ml, PS 96 well block, polystyrene, transparent, with barcode 1.2ml volume per well, round wells. W: 127.5mm; D: 85.5mm; H: 41mm 32 pcs/case, 4 plates are wrapped	
6473-01	DEEP WELL BLOCK 2.2ml, PP 96 well block, polypropylene, 2.2ml volume per well, square wells, round bottom. W: 126.3mm; D: 84.7mm; H: 40.6mm 32 pcs/case, 4 plates are wrapped	
235656	DEEP WELL BLOCK 2.2ml, PP 96 well block, polypropylene, with barcode, 2.2ml volume per well, square wells, round bottom. W: 126.3mm; D: 84.7mm; H: 40.6mm 32 pcs/case, 4 plates are wrapped	
6474-01	SEALING MAT Sealing mat for 2.2ml blocks, ethylenevinylacetate W: 121.5mm; D: 78.8mm; H: 4.68mm 50 pcs/case, 10 pcs/bag	

8.2.15 Liquids for Maintenance





Liquids for Maintenance		
Part Number	Description	Image
289014	HEAT EXCHANGE SOLUTION FOR TCC Color-coded heat exchange liquid for TCC cooler	
281242	MICROLAB DETERGENT & DISINFECTANT KIT contents: 1 beaker 100ml 3x 1l bottles Deconex® 61 DR	
281243	MICROLAB DISINFECTANT SPRAY KIT contents: 4x 500ml Deconex® SOLARSEPT spray bottles	
281245	MICROLAB DISINFECTANT STARTER KIT contents: 1 Beaker 100ml 2x 500ml Deconex® SOLARSEPT spray bottles 1x 1l bottle Deconex® 61 DR	

8.2.16 Plate Carrier

Plate Carrier		
Part Number	Description	Image
182035	PLT_CAR_L5PCR384 Carrier for 5x 384 PCR plates	
182065	PLT_CAR_P3AC Carrier for 3x Deep Well Plates, portrait orientation (6T)	
182070	PLT_CAR_L5PCR Carrier for 5x 96-well PCR plates (6T)	
182075	PLT_CAR_P3MD Carrier for 3x 96/384 well plates, portrait orientation (6T)	
182090	PLT_CAR-L5AC Carrier for 5x 96 Deep Well Plates or for 5x 384 tip racks (e.g.384HEAD_384TIPS_50µl) (6T)	
191287	PLT-CAR-L4HD Carrier for 4x 1536-well plates (6T)	
182190	PLT-CAR-P3HD Carrier for 3 x 1536-well plates, portrait orientation (6T)	
182365	PLT_CAR_L5MD Carrier for 5x 96/384-well plates (6T)	
185295	PLT_CAR_L5AC PINNED Carrier for 5x Hamilton DWP (6T)	
185330	PLT_CAR_L4ST (4x8 MTP) Stacker carrier for 4 x 8 MTP (7T)	
185340	PLT_CAR_L4ST (4x5 MTP) Stacker carrier for 4 x 5 MTP (7T)	
182735	PLT_CORE_COVER Lid to cover MTP on standard carriers	
187223	ANTI-EVAPORATION LID Lid for minimizing evaporation of liquid in MTP. Typically used for protein crystallization plate preparation. Can be handled by the iSWAP or CO-RE gripper. Requires P/N 188054APE PLT-CAR-L4-Crystal.	

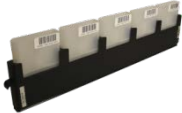
Plate Carrier		
Part Number	Description	Image
182712	FRAME FOR FILTER PLATE To place filter plates on archive carriers	

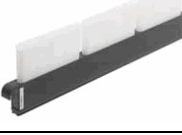





8.2.17 Reagent Carrier

Reagent Carrier		
Part Number	Description	Image
194057	RGT_CAR_5R60 Reagent Carrier for 5x reagent troughs (1T) For reagent container P/N 194051, 60ml	
187239	RGT_CAR_4R100 Reagent Carrier for 4x reagent troughs 100ml (1T) For reagent container with lids (P/N 187236) or reagent container without lids (P/N 187244), 100ml	
182080	RGT_CAR_12R Reagent Carrier for 12x reagent troughs 100ml (1T) For reagent container P/N 137257, 100ml	
185290	RGT_CAR_3R Reagent Carrier for 3x reagent troughs 120ml (1T) For reagent container P/N 182703, 120ml	
194058	RGT_CAR_3R120 Reagent Carrier for 5x reagent troughs 120ml (1T) For reagent container P/N 194052, 120ml	
185436	RGT_CAR_4R200 Reagent Carrier for 4x reagent troughs 200ml (1T) For reagent container P/N 56695-01/56695-02 2T, 200ml	





8.2.18 Tip Carrier



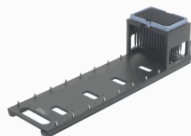

Tip Carrier		
Part Number	Description	Image
182060	TIP_CAR_288 Carrier for 3x 96 tip racks portrait for 12-pipetting channel (1000µl) ML STAR or 3x 24 tip racks portrait for 6-pipetting channel (5ml) ML STAR (4T)	
182085	TIP_CAR_480 Carrier for 5x 96 tip (10µl, 50µl, 300µl, 1000µl) racks or 5x 24 tip (5ml) racks (6T)	
182390	TIP_CAR_L384_A00 Carrier for 4x 96 tip racks for 16-channel (1000µl) ML STAR or 3x 24 tip racks portrait for 8-channel (5ml) ML STAR (6T)	
182074	TIP_CAR_NTR_A00 Carrier for Nested Tip Racks (NTR) 6T; for 1 pack tray containing 1920x 10µl, 50µl, 300µl CO-RE tips (5 stacks x 4 tip racks x 96 tips) or 7680x 50µl CO-RE tips for 384 Probe Head (5 stacks x 4 tip racks x 384 tips)	
182040	ADAPTER FOR TIP_CAR_480 Intermediate storage position for tips allows pick-up of a single tip/row/column using the CO-RE 96 Probe Head	
191055	384 TIP SUPPORT Intermediate storage position for tips allows pick-up of a single tip/row/column using the CO-RE 384 Probe Head The tip support fits into Multiflex tip module (P/N 188160) or tip carrier (P/N 182085)	
191056	ROCKET TIP SUPPORT Intermediate storage position for tips allows pick-up of a single tip/row/column using the CO-RE 384 Probe Head The tip support fits into Multiflex Tip Module (P/N 188160) or tip carrier (P/N 182085)	
182041	DRIP PAN FOR TIP CARRIER	

8.2.19 Sample Tube Carrier and Inserts

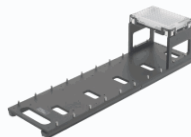
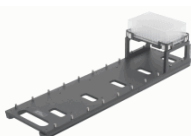
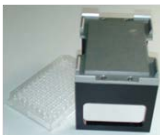

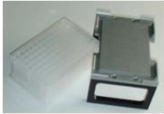





Sample Tube Carrier and Inserts		
Part Number	Description	Image
173400	4 SMP-CAR-24 Set of 4x sample carrier for 24 tubes sizes 14.5x60 – 18x120mm (1T)	
173410	3 SMP-CAR-32 Set of 3x sample carrier for 32 tubes sizes 11x60 – 14x120mm (1T)	
182045	SMP-CAR-12 Sample Carrier for 12 Falcon tubes 50ml (2T)	
185346	TUBE CARRIER FILLING RACK Holds up to four 1T sample carriers for loading and filling of tubes in the carriers. Compatible with 1T sample carriers 24, 32.	
190070	RACK HOLDER Holds up to four 1T sample carriers for loading and filling tubes in carriers and transporting up to four sample carriers to and from a ML STAR workstation. Compatible with 1T sample carriers 24, 32.	
182238	EPI-INS-32L Set of 32 inserts for 1.5ml Eppendorf cups in SMP-CAR-32	
182239	EPI-INS-32S Set of 32 inserts for 0.5ml Eppendorf cups in SMP-CAR-32	
187142	24-FALCON-INS-15ML Set of 24 inserts for 15ml Falcon tubes in SMP-CAR-24	
187350	8 INSERTS FOR 1.5ML EPPENDORF CUPS IN SMP-CAR-32 Set of 8 inserts for 1.5ml Eppendorf cups in SMP-CAR-32	
185393	SET OF INSERTS 24/16.5MM 24 Set of 24 inserts for tubes with outer diameter < 16.5mm in SMP-CAR-24	
There are more inserts available. Please consult a local Hamilton representative.		

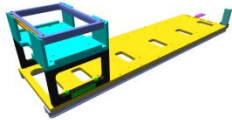
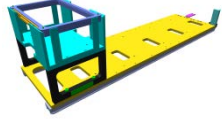
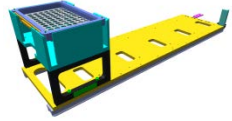

8.2.20 Multiflex Carrier

Multiflex Carrier		
Part Number	Description	Image
188039	MULTIFLEX CARRIER BASE (LANDSCAPE ORIENTATION) Labware carrier base for up to 5 Multiflex Modules	
188160	MULTIFLEX TIP MODULE Module to position a high-, standard-, low volume or 5ml tip rack (but not a 384 tip rack) The Multiflex carrier base is not included.	
191420	MULTIFLEX NTR 96 MODULE Module to position a Nested Tip Rack (NTR) with standard (300µl), low volume (10µl) or 50µl tips The Multiflex carrier base is not included.	
196371	MULTIFLEX NTR 384 MODULE Module to position a Nested Tip Rack (NTR) with 384 50µl tips The Multiflex carrier base is not included.	
191425	MULTIFLEX NTR4 MODULE Module to position a stack of 4 Nested Tip Racks (NTR) with standard (300µl), low volume (10µl) or 50µl tips The Multiflex carrier base is not included.	
188041	MULTIFLEX MTP MODULE Module to position 96-/384-well plates in SBS format / or flat reagent troughs The Multiflex carrier base is not included.	
188042	MULTIFLEX DWP MODULE Module to position a Deep Well Plate / tube racks (MATRIX or MICRONICS) / NUNC reagent trough The Multiflex carrier base is not included.	
188094APE	MULTIFLEXMTPNESTCONTBASED Module to hold a microplate by supporting the wells on a Multiflex Carrier. The Multiflex carrier base is not included. Alternatively the module can be mounted on a PLT_CAR_L4_SHAKER base plate, P/N 187001. This requires P/N 188133APE MULTIFLEXMODULEBRACKET7T for fixation.	





Multiflex Carrier		
Part Number	Description	Image
188228APE	<p>MULTIFLEXMTPNESTRACKBASED</p> <p>Module to hold the frame of a microplate on a Multiflex Carrier. The Multiflex carrier base is not included.</p> <p>Alternatively the module can be mounted on a PLT_CAR_L4_SHAKER base plate, P/N 187001. This requires P/N 188133APE MULTIFLEXMODULEBRACKET7T for fixation.</p>	
188293	<p>MULTIFLEXXLDPNESTRACKBASED</p> <p>Module to position any SBS format plate, including Deep Well Plates up to H=90mm / or flat reagent containers. Plates are held on their frame.</p> <p>The Multiflex carrier base is not included.</p> <p>Alternatively the module can be mounted on a PLT_CAR_L4_SHAKER base plate, P/N 187001. This requires P/N 188133APE MULTIFLEXMODULEBRACKET7T for fixation.</p>	
188180APE	<p>MULTIFLEXDWPNESTCONTBASED</p> <p>Module to hold a Deep Well Plate by supporting the wells on a Multiflex Carrier.</p> <p>The Multiflex carrier base is not included.</p> <p>Alternatively the module can be mounted on a PLT_CAR_L4_SHAKER base plate, P/N 187001. This requires P/N 188133APE MULTIFLEXMODULEBRACKET7T for fixation.</p>	
188043	<p>CO-RE GRIPPER ON MULTIFLEX MODULE</p> <p>Plate handling tool for plate transfer on the deck using two pipetting channels. Includes module with parking position for CO-RE gripper.</p> <p>The Multiflex carrier base is not included.</p>	
188044	<p>MULTIFLEX STACKER MODULE (LANDSCAPE)</p> <p>Module to use as passive plate hotel. Depending on plate height, up to 10 plates can be stacked on one position.</p> <p>The Multiflex carrier base is not included.</p>	
188045	<p>MULTIFLEX HEATING MODULE</p> <p>Heating module (up to 60°C) including one adapter for one labware type.</p> <p>Temperature: Room temperature up to 60°C Temperature gradient: ± 1°C</p> <p>The Multiflex carrier base is not included.</p>	
188046	<p>MULTIFLEX COOLING MODULE</p> <p>Cooling module (4 - 15°C) including one adapter for one labware type.</p> <p>Temperature: 4 – 15 °C. Temperature gradient: ± 1°C</p> <p>The Multiflex carrier base is not included.</p>	

Multiflex Carrier		
Part Number	Description	Image
808440	<p>MULTIFLEX COOLING-HEATING MODULE</p> <p>Module to cool or heat one labware type. Temperature: 4°C - 95°C Dry mode feature. The Multiflex carrier base is not included.</p>	
188047	<p>MULTIFLEX REAGENT TROUGH MODULE</p> <p>Module to hold six 50ml troughs The Multiflex carrier base is not included.</p>	
188048	<p>MULTIFLEX TUBE / CUP MODULE</p> <p>Module to hold EPPENDORF, SARSTEDT, NUNC tubes 0.5ml / 1.5ml / 2.0ml with or without snap-lid in an passively cooled adapter The Multiflex carrier base is not included.</p>	
188049	<p>MULTIFLEX PCR PLATE MODULE 96</p> <p>Module to position a 96-well PCR plate. The Multiflex carrier base is not included.</p>	
188052	<p>MULTIFLEX PCR PLATE MODULE 384</p> <p>Module to position a 384-well PCR plate The Multiflex carrier base is not included.</p>	
188053	<p>MULTIFLEX CARRIER BASE (PORTRAIT ORIENTATION)</p> <p>Labware carrier base for up to 3 Multiflex modules</p>	
188055APE	<p>PLATE TURNTABLE</p> <p>Automated device to turn plates from landscape into portrait orientation or vice-versa The Multiflex carrier base is not included.</p>	
188313	<p>MULTIFLEX MATRIX FIXATION FRAME FOR 1.4ML MATRIX TUBES 47.1mm</p> <p>Module to hold down sealed Matrix tubes in a 96well tube rack for piercing using needles or tips. Supports one pierceable SBS format 96well tube rack. Requires a Multiflex MTP Module (P/N 188041, not included) and a Multiflex carrier base (not included). Piercing needles not included.</p>	
188095	<p>MULTIFLEX MTP FIXATION FRAME 16.6mm</p> <p>Module to hold down sealed plates for piercing using needles or tips. Supports one pierceable SBS format plate. The Multiflex carrier base and piercing needles are not included.</p>	

Multiflex Carrier		
Part Number	Description	Image
188295	<p>MULTIFLEX MTP FIXATION FRAME FOR AGENTCOURT 384 26.2mm</p> <p>Module to hold down sealed plates for piercing using needles or tips. Supports one pierceable SBS format plate.</p> <p>The Multiflex carrier base and piercing needles are not included.</p>	
188395	<p>MULTIFLEX MTP FIXATION FRAME FOR AGENTCOURT 96 38.6mm</p> <p>Module to hold down sealed plates for piercing using needles or tips. Supports one pierceable SBS format plate.</p> <p>The Multiflex carrier base and piercing needles are not included.</p>	
188495	<p>MULTIFLEX MTP FIXATION FRAME FOR QIAGEN 31mm</p> <p>Module to hold down sealed plates for piercing using needles or tips. Supports one pierceable SBS format plate.</p> <p>The Multiflex carrier base and piercing needles are not included.</p>	
188058APE	<p>MULTIFLEX LID PARKING MODULE</p> <p>Module to park the lid of the cooling or heating module.</p> <p>The Multiflex carrier base is not included.</p>	
188059	<p>MULTIFLEX PLATE STACKER MODULE (PORTRAIT)</p> <p>Module to use as passive plate hotel. Depending on plate height, up to 10 plates can be stacked on one position.</p> <p>The Multiflex carrier base is not included.</p>	
188114APE	<p>MULTIFLEX LIQUID DISPENSER TROUGH 8</p> <p>Module to automatically refill a trough on the deck with fresh reagent. Compatible with 8-channel instruments.</p> <p>The Multiflex carrier base is not included.</p>	
188061APE	<p>MULTIFLEX TILT MODULE</p> <p>Module to tilt plates on the y-axis (in landscape orientation)</p> <p>The Multiflex carrier base is not included.</p>	
188062	<p>MULTIFLEX TIP STACKER MODULE</p> <p>Module to hold 4 standard volume or 6 low volume tip racks on one position</p> <p>The Multiflex carrier base is not included.</p>	
188063APE	<p>MULTIFLEX SEESAW MODULE</p> <p>Module to shake bead-, cell-, or reagent solutions at a predefined speed in troughs or plates. Angle is adjustable up to 15°. 16-69 rpm adjustable in 4 steps.</p> <p>The Multiflex carrier base is not included.</p>	
188115APE	<p>MULTIFLEX LIQUID DISPENSER TROUGH 96</p> <p>Module to automatically refill a trough on the deck with fresh reagent. Compatible with 96-channel instruments.</p> <p>The Multiflex carrier base is not included.</p>	

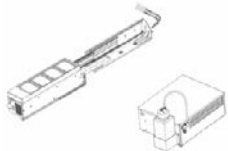
Multiflex Carrier		
Part Number	Description	Image
188078APE	MULTIFLEX STERILE TIP BOX MODULE Module to store sterile tips on the deck.	
182774	STAR SHELF 4MTP/2AC PLATES Shelving Unit for 4 MTP or 2 archive plates	

8.2.21 Temperature Controlled Carrier (TCC)

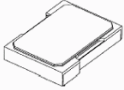
Temperature Controlled Carrier (TCC)		
Part Number	Description	Image
182400	TCC FOR ML STAR/PLATES Temperature Controlled Carrier for MTP (no DWP)	
182436	TCC-RGT-TUB 100ml reagent tub with lid for TCC	
182532	TCC-PCR-PLT-ADAPTER KIT 96 Set of 4 TCC-adapter for 96-well PCR plates	
182673	TCC-PCR-PLT-ADAPTER KIT 384 Set of 4 TCC-adapter for 384-well PCR plates	
182734	TCC-LID-ADAPTER KIT Set of 4 lids to cover plates on the TCC	



8.2.22 CVS Vacuum System

CVS Vacuum System		
Part Number	Description	Image
199020 190021	<p>CVS VACUUM SYSTEM INCLUDING PUMP (230V) CVS VACUUM SYSTEM INCLUDING PUMP (115V)</p> <p>Carrier with a vacuum box, one park position for manifold top and two plate positions including Vacuubrand Pump ME 4C VARIO with controller, pressure sensor and air-bleed valve (Waste bottles are not included. Please select P/N 281540)</p>	
187143 187149	<p>TELESHAKER 220V FOR DWP TELESHAKER 115V FOR DWP</p> <p>Maximum one shaker per CVS carrier.</p>	
187788	<p>SHAKER HEATER CAT SH10 FOR DWP (110/220V)</p> <p>Shaker heater (Shaking: 200 - 1200 1/min, orbital: 2mm, temperature: from RT+5°C - 90°C) for standard 96 and Deep Well Plates</p> <p>Maximal one shaker heater per CVS carrier.</p>	
281540	<p>BVS 4-LITER WASTE BOTTLE</p> <p>PP waste bottle for the BVS / CVS with confectioned cap, including connectors and LDPE Bucket 11L</p> <p>Instruction sheet</p>	
190034	<p>DWP KIT FOR BVS</p> <p>Manifold Top for BVS / CVS and insert to adapt the BVS / CVS to the used collecting plate</p>	
186320	<p>BVS INSERT KIT</p> <p>Adjustable insert to adapt the BVS / CVS to the used collecting plate</p> <p>Contains two different spacers: H = 30mm and H = 45mm</p> <p>Adapter: H = 15mm</p> <p>Range: 45mm to 60mm. Bottom of Elution Plate will be 27.4mm to 42.4mm below the Gasket of the Manifold top (contact surface filter plate). Round up/down to 28mm to 42mm (nominal values).</p>	





CVS Vacuum System		
Part Number	Description	Image
190035	<p>BVS INSERT KIT FOR MTP</p> <p>Insert to adapt the BVS / CVS to the used collecting plate Contains two different spacers: H = 15mm and H = 30mm Adapter: H = 17mm Range: 32mm to 47mm. Bottom of Elution Plate will be 40.4mm to 55.4mm below the Gasket of the Manifold top (contact surface filter plate). Round up/down to 41mm to 55mm (nominal values).</p>	
190036	<p>BVS INSERT KIT FOR DWP</p> <p>Insert to adapt the BVS / CVS to the used collecting plate Contains no spacers Adapter: H = 5mm No Range: Bottom of Elution Plate will be 82.4mm below the Gasket of the Manifold top (contact surface filter plate). Round down to 82mm (nominal values).</p>	
190037	<p>BVS GRID I FOR MILLIPORE</p> <p>Manifold Top for BVS / CVS incl. Grid I for Millipore Kits "Montage Plasmid Miniprep96 Kit" and "Montage PCR96 Cleanup Kit"</p>	
186321	<p>BVS GRID II FOR MILLIPORE</p> <p>Manifold Top for BVS / CVS incl. Grid II for Millipore Kits with 96/384 SBS plates with one filter</p>	
186303	<p>BVS ADAPTER FOR MN DNA KIT</p> <p>Insert to adapt the BVS / CVS to the used collecting plate</p>	
182712	<p>FRAME FOR FILTER PLATE</p> <p>To place filter plates on archive carriers</p>	

8.2.23 Hamilton Heater Shaker

Shaker		
Part Number	Description	Image
187001	<p>PLT_CAR_L4_SHAKER</p> <p>Template carrier with 4 positions for Hamilton Heater Shaker (optional: Shaker H+P, Shaker Heater CAT) and plate bases (7T)</p>	
190755	<p>HEATER SHAKER BOX</p> <p>Needed if more than two Hamilton Heater Shakers are integrated (or the connectors "TCC1", "TCC2" on the ML STAR are occupied by other devices). One heater shaker module is connected to a USB port of the PC and serves as master module for up to seven additional HHSs. The modules are connected to the external heater shaker box (HSB), which serves as power supply and as signal distributor.</p>	
199013	<p>HEATER SHAKER SUPPORT BLOCK FOR MTP</p> <p>Hamilton Heater Shaker support block for MTP. Used to raise the heater shaker if only MTPs are processed.</p>	
199027	<p>HEATER SHAKER 1.5MM SARSTEDT 48 X 1.5ML</p> <p>Hamilton Heater Shaker with 1.5mm shaking orbit and fitted adapter for plates (shaking speed: 100 -1800 rpm, temperature control: RT+5°C - 105°C, max. loading: 300mm)</p> <p>Sarstedt tubes 1.5ml:</p> <p>sterile Sarstedt Cat. No. 72.687.772</p> <p>non-sterile Sarstedt Cat. No. 72.687</p> <p>http://www.Sarstedt.com</p>	
199033	<p>HEATER SHAKER 2.0MM MTP FLAT BOTTOM</p> <p>Hamilton Heater Shaker with 2.0mm shaking orbit and flat bottom adapter (shaking speed: 100 -2500 rpm, temperature control: RT+5°C - 105°C, max. loading: 300mm)</p>	
199034	<p>HEATER SHAKER 3.0MM FLAT BOTTOM</p> <p>Hamilton Heater Shaker with 3.0mm shaking orbit and flat bottom adapter (shaking speed: 100 -2400 rpm, temperature control: RT+5°C - 105°C, max. loading: 300mm)</p>	
199037	<p>HEATER SHAKER 1.5MM NUNC DWP 96 2ML</p> <p>Heater Shaker with 1.5mm shaking orbit and fitted adapter for plates (shaking speed: 100 -2000 rpm, temperature control: RT+5°C - 105°C, max. loading: 300mm)</p>	
199038	<p>HEATER SHAKER 2.0MM NUNC DWP 96 2ML</p> <p>Hamilton Heater Shaker with 2.0mm shaking orbit and fitted adapter for plates (shaking speed: 100 -2000 rpm, temperature control: RT+5°C - 105°C, max. loading: 300mm)</p>	

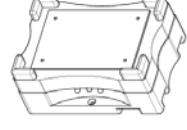

Shaker		
Part Number	Description	Image
199039	HEATER SHAKER 3.0MM NUNC DWP 96 2ML Hamilton Heater Shaker with 3.0mm shaking orbit and fitted adapter for plates (Shaking speed: 100 -1800 rpm, Temperature control: RT+5°C - 105°C, max. loading: 300mm)	
188318	HEATER SHAKER 2.0MM MTP FLAT BOTTOM APE Hamilton Heater Shaker with 2.0mm shaking orbit and the option to be equipped with a customized adapter. The labware has to be sent to Hamilton Bonaduz AG. (Shaking speed depends on used adapter, temperature control: RT+5°C - 105°C, max. loading: 300mm)	
188319	HEATER SHAKER 3.0MM MTP FLAT BOTTOM APE Hamilton Heater Shaker with 3.0mm shaking orbit and the option to be equipped with a customized adapter. The labware has to be sent to Hamilton Bonaduz AG. (shaking speed depends on used adapter, temperature control: RT+5°C - 105°C, max. loading: 300mm)	

8.2.24 3rd Party Shakers

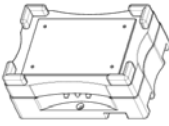
Shaker		
Part Number	Description	Image
187143 187149	TELESHAKER 220V FOR DWP TELESHAKER 115V FOR DWP Shaker (shaking: 100 - 2000 1/min, orbital: 2mm) for standard 96 and Deep Well Plates on the PLT_CAR_L4_shaker (7T)	
187295 187296	TELESHAKER 220V FOR MTP TELESHAKER 115V FOR MTP Shaker (Shaking: 100 - 2000 1/min, Orbital: 2mm) for standard 96-well plates (no DWP) on the PLT_CAR_L4_shaker (7T)	
187144	DWP BASE FOR SHAKER CAR Position for standard and Deep Well Plates on the PLT_CAR_L4_shaker (7T)	
187292	MTP BASE FOR SHAKER CAR Positions for standard well plates (no DWP) on the PLT_CAR_L4_shaker (7T)	
187788	SHAKER HEATER CAT SH10 FOR DWP (110/220V) Shaker heater (shaking: 200 - 1200 1/min, orbital: 2mm, temperature: from RT+5°C - 90°C) for standard 96 and Deep Well Plates on the PLT_CAR_L4_shaker (7T)	

Shaker		
Part Number	Description	Image
187789	<p>SHAKER HEATER CAT SH10 FOR MTP (110/220V)</p> <p>Shaker heater (shaking: 200 - 1200 1/min, orbital: 2mm, temperature: from RT+5°C - 90°C) for standard 96-well plates (no DWP) on the PLT_CAR_L4_shaker (7T)</p>	

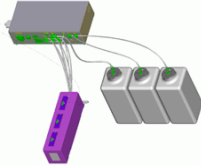
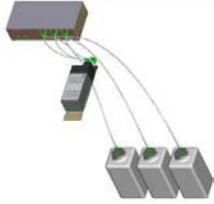

8.2.25 Wash Stations



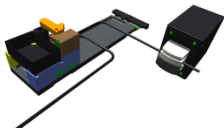

Wash Stations		
Part Number	Description	Image
186360	<p>CR NEEDLE WASH STATION</p> <p>Wash Station for all needle types, two wash liquids, needle wash in parallel to the pipetting</p>	
190248	<p>96/384 WASH STATION DUAL</p> <p>Wash Station for 96/384 disposable tips, CO-RE 384 Probe Head, 2 wash chambers</p>	
281107	<p>WASH / WASTE CONTAINER 12 LITER</p> <p>Wash and waste container for wash stations</p>	

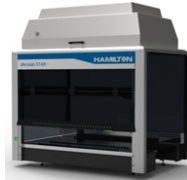
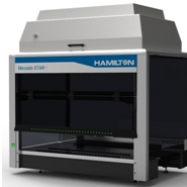
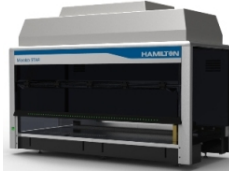
8.2.26 Multiflex Media Line

188156	MULTIFLEX MEDIA LINE	
--------	-----------------------------	---------------------------------------------------------------------------------------

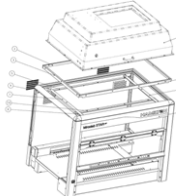
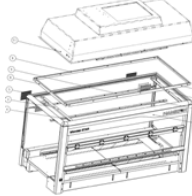
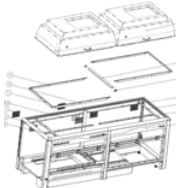
8.2.27 HEPA Filter Hoods

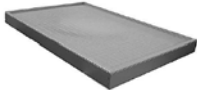





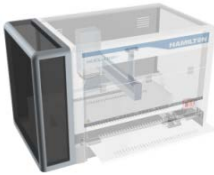



HEPA Filter Hoods		
Part Number	Description	Image
55500-01	<p>HOOD FLOW STARLET</p> <p>Hood mounting on top of a ML STARlet; supplies filtered clean air to the inside of a ML STARlet workstation. Flow is laminar. Flow volume is controllable by software.</p> <p>Adds 321 mm to height of workstation.</p> <p>A seal kit for the ML STARlet (P/N 188232) is required when ordering this item. It has to be ordered separately.</p>	
55501-01	<p>HOOD FLOW STARLET UV</p> <p>Hood mounting on top of a ML STARlet; supplies filtered clean air to the inside of a ML STARlet workstation. Flow is laminar. Flow volume is controllable by software. Includes UV lamps.</p> <p>Adds 321mm to the workstation height.</p> <p>A seal kit for the ML STARlet (P/N 188232) is required when ordering this item. It has to be ordered separately.</p> <p>UV Light requires UV resistant covers which have to be ordered separately. Please consult a Hamilton representative.</p>	
55495-01	<p>HOOD FLOW STAR</p> <p>Hood mounting on top of a ML STAR; supplies filtered clean air to the inside of a ML STAR workstation. Flow is laminar. Flow volume is controllable by software.</p> <p>Adds 321mm to the workstation height.</p> <p>A seal kit for the ML STAR (P/N 188233) is required when ordering this item. It has to be ordered separately.</p>	
55496-01	<p>HOOD FLOW STAR UV</p> <p>Hood mounting on top of a ML STAR; supplies filtered clean air to the inside of a ML STAR workstation. Flow is laminar. Flow volume is controllable by software. Includes UV lamps.</p> <p>Adds 321mm to the workstation height.</p> <p>A seal kit for the ML STAR (P/N 188233) is required when ordering this item. It has to be ordered separately.</p> <p>UV Light requires UV resistant covers which have to be ordered separately. Please consult a Hamilton representative.</p>	
55506-01	<p>HOOD STARPLUS</p> <p>Hood mounting on top of a ML STARPlus; supplies filtered clean air to the inside of a ML STARPlus workstation. Flow is laminar. Flow volume is controllable by software.</p> <p>Adds 321mm to the workstation height.</p> <p>A seal kit (P/N 188234) is required when ordering this item. It has to be ordered separately.</p>	

<p>55507-01</p>	<p>HOOD STARPLUS UV</p> <p>Hood mounting on top of a ML STARPlus; supplies filtered clean air to the inside of a ML STARPlus workstation. Flow is laminar. Flow volume is controllable by software. Includes UV lamps.</p> <p>Adds 321mm to the workstation height.</p> <p>A seal kit (P/N 188234) is required when ordering this item. It has to be ordered separately.</p> <p>UV Light requires UV resistant covers which have to be ordered separately. Please consult a Hamilton representative.</p>	
<p>188232</p>	<p>STARLET HEPA-HOOD KIT</p> <p>Seal kit required for the HEPA Filter Hood of HOOD FLOW STARLET, P/N 55500-01, HOOD FLOW STARLET UV, P/N 55501-01</p>	
<p>188233</p>	<p>STAR HEPA-HOOD KIT</p> <p>Seal kit required for the HEPA Filter Hood of HOOD FLOW STAR, P/N 55495-01, HOOD FLOW STAR UV, P/N 55496-01</p>	
<p>188234</p>	<p>STARPLUS HEPA-HOOD KIT</p> <p>Seal kit required for the HEPA Filter Hood of HOOD FLOW STAR, P/N 55506-01-01, HOOD FLOW STAR UV, P/N 55507-01</p>	
<p>51015-01</p>	<p>FILTER, PLEATED, 14X18X1</p>	
<p>51011-01</p>	<p>FILTER, HEPA, 18X24X3</p>	
<p>51476-01</p>	<p>LAMP UV, STARLINE</p> <p>Length: 45.7cm, 17Watt</p>	

8.2.28 Housing Extension

Housing Extension		
Part Number	Description	Image
188122	<p>HOUSING EXTENSION MPH</p> <p>This housing extension can be mounted on either side of ML STAR instruments.</p> <p>If used on the left hand side on instruments with modular arm and MPH (96 or 384), the following waste has to be ordered separately; either: 188124APE WASTE MPH L REAR or, 188125APE WASTE MPH L FRONT</p> <p>If used on the left hand side on instruments with 'thin-' arm and MPH (96 or 384) the following waste has to be ordered separately; either: 188124APE WASTE MPH L REAR or, 188125APE WASTE MPH L FRONT</p> <p> NOTE <i>Slide waste for MPH's (96 or 384) will not fit.</i></p> <p>In conjunction with one of the following HEPA hoods, a seal kit (P/N 188235) is required when ordering this item. It has to be ordered separately.</p> <p>P/N 55500-01 HOOD FLOW STARLET P/N 55501-01 HOOD FLOW STARLET UV P/N 55495-01 HOOD FLOW STAR P/N 55496-01 HOOD FLOW STAR UV P/N 55506-01 HOOD STARPLUS P/N 55507-01 HOOD STARPLUS UV</p> <p>UV Light requires UV resistant covers which have to be ordered separately. Please consult a Hamilton representative.</p>	
188235	<p>HOUSING EXTENSION MPH HEPA-HOOD KIT</p> <p>Seal kit required for the HEPA Filter Hood of HOUSING EXTENSION MPH, P/N 188122</p>	



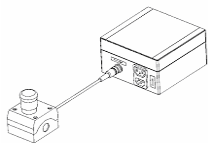

8.2.29 CO-RE Tools

CO-RE Tools		
Part Number	Description	Image
188066	<p>CO-RE GRIPPER WITH ATTACHMENT FOR WASTE BLOCK Plate handling tool for plate transfer on the deck using 2 1000μl-pipetting channels. Includes parking position for attachment to waste block (waste block not included).</p> <p> NOTE <i>Order this gripper if the ML STAR instrument is equipped with 1000μl-pipetting channels only.</i></p>	
184089	<p>CO-RE GRIPPER WITH ATTACHMENT FOR WASTE BLOCK (FOR INSTRUMENTS WITH 1000UL AND 5ML PIPETTING CHANNELS) Plate handling tool for plate transfer on the deck using 2 1000μl-pipetting channels. Includes parking position for attachment to waste block (waste block not included).</p> <p> NOTE <i>Order this gripper if the ML STAR instrument is equipped with 1000μl-pipetting channels and 5ml-pipetting channels.</i></p>	
184099	<p>CO-RE GRIPPER WITH ATTACHMENT FOR WASTE BLOCK (FOR INSTRUMENTS WITH 1000UL AND 5ML PIPETTING CHANNELS) Plate handling tool for plate transfer on the deck using 2 5ml-pipetting channels. Includes parking position for attachment to waste block (waste block not included).</p> <p> NOTE <i>Order this gripper if the ML STAR instrument is equipped with 5ml-pipetting channels.</i></p>	
186100	<p>CO-RE GRIPPER Gripper tool for plate transport with pipetting channels, including parking position.</p> <p> NOTE <i>This gripper can be installed by removing a plate position of the plate carrier PLT_CAR_L5MD, P/N 182365</i></p>	
188227APE	<p>CO-RE LID TOOL (CLT) Suction cup that can be picked up by a CO-RE pipetting channel to move lids.</p>	
188082APE	<p>REPLACEMENT CO-RE LID TOOL (CLT) Replacement suction cup.</p>	

8.2.30 Emergency Stop Box

Emergency Stop Box		
Part Number	Description	Image
186060	EMERGENCY STOP BOX Category 0 Emergency Stop Button	





8.2.31 Mains Power Cables

Mains Power Cables		
Part Number	Description	Image
355234	POWER CABLE EU, 2.50m C13	
355235	POWER CABLE CH, 2.50m C13	
355236	POWER CABLE US, 2.50m C13	
355237	POWER CABLE UK, 2.50m C13	

8.2.32 Hamilton Standard Computers

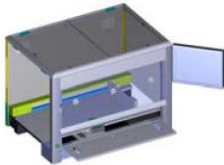
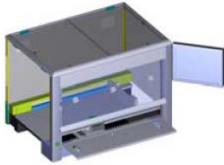
Hamilton Standard Computers		
Part Number	Description	Image
	WINDOWS 7 ULTIMATE COMPUTERS	
396258	STANDARD PC WIN7 CH Swiss German	
396259	STANDARD PC WIN7 FR French	
396260	STANDARD PC WIN7 US US English	
396261	STANDARD PC WIN7 ES Spanish	
396262	STANDARD PC WIN7 IT Italian	
396263	STANDARD PC WIN7 GE German	
396264	STANDARD PC WIN7 GB UK English (The mains power cable is not included)	
Refer to Section 7.11 Hamilton Standard PC Specifications		

8.2.33 Touch Screen Monitor for the ML STAR

Touch Screen Monitor for the ML STAR		
Part Number	Description	Image
188250	19" TOUCH SCREEN KIT SHADED (Mains power cable not included)	
188260	19" TOUCH SCREEN KIT CLEAR (Mains power cable not included)	
355010	MAINS POWER CABLE DE	
355020	MAINS POWER CABLE CH	
355009	MAINS POWER CABLE US	

Touch Screen Monitor for the ML STAR		
Part Number	Description	Image
235062	MAINS POWER CABLE GB	

8.2.34 VENUS Software

VENUS Software	
Part Number	Description
911264	VENUS FOUR BASE PACK V4.5
911095	VENUS ONE DYNAMIC SCHEDULER (This package is compatible to VENUS four)
911099	VENUS ONE TADM FEATURE (This package is compatible to VENUS four)
911122	VENUS ONE DATA BASE PLUS (This package is compatible to VENUS four)
627043	ML STAR OPERATOR'S MANUAL
627044	ML STAR PROGRAMMER'S MANUAL

8.3 Appendix C: Instrument Dimensions

8.3.1 ML STARlet, Manual Load, Shown Without Housing

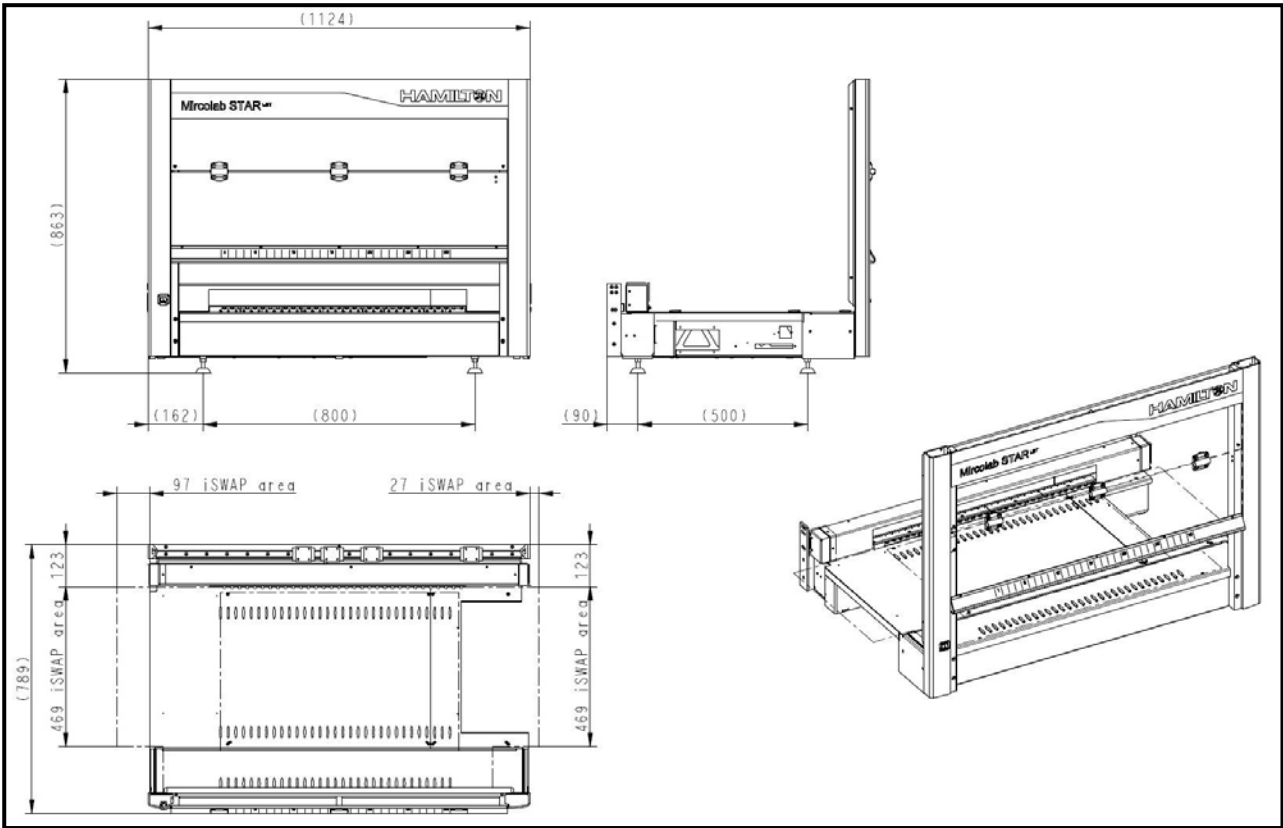

8.3.2 ML STARlet, Autoload

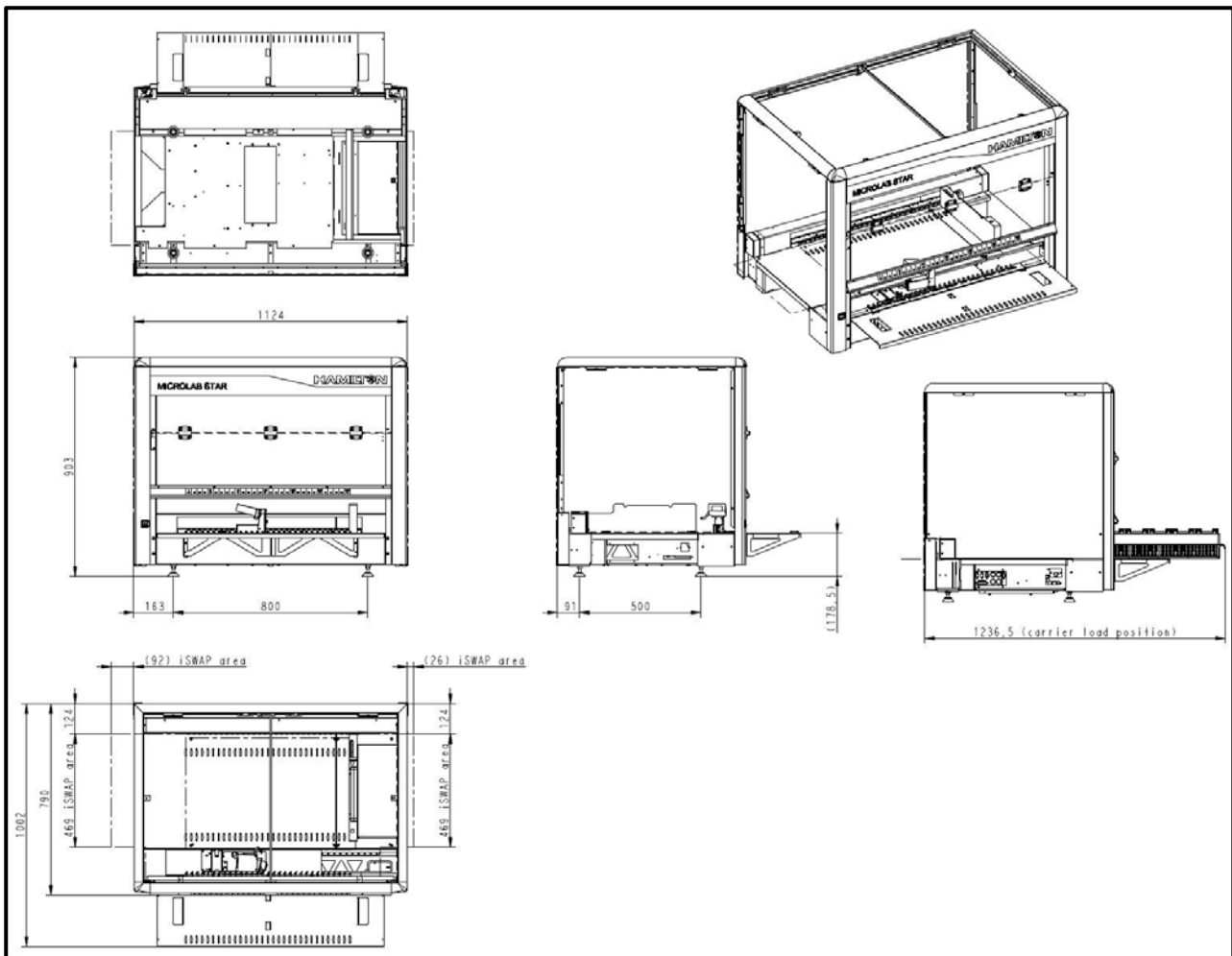

8.3.3 ML STARlet, Autoload, MPH

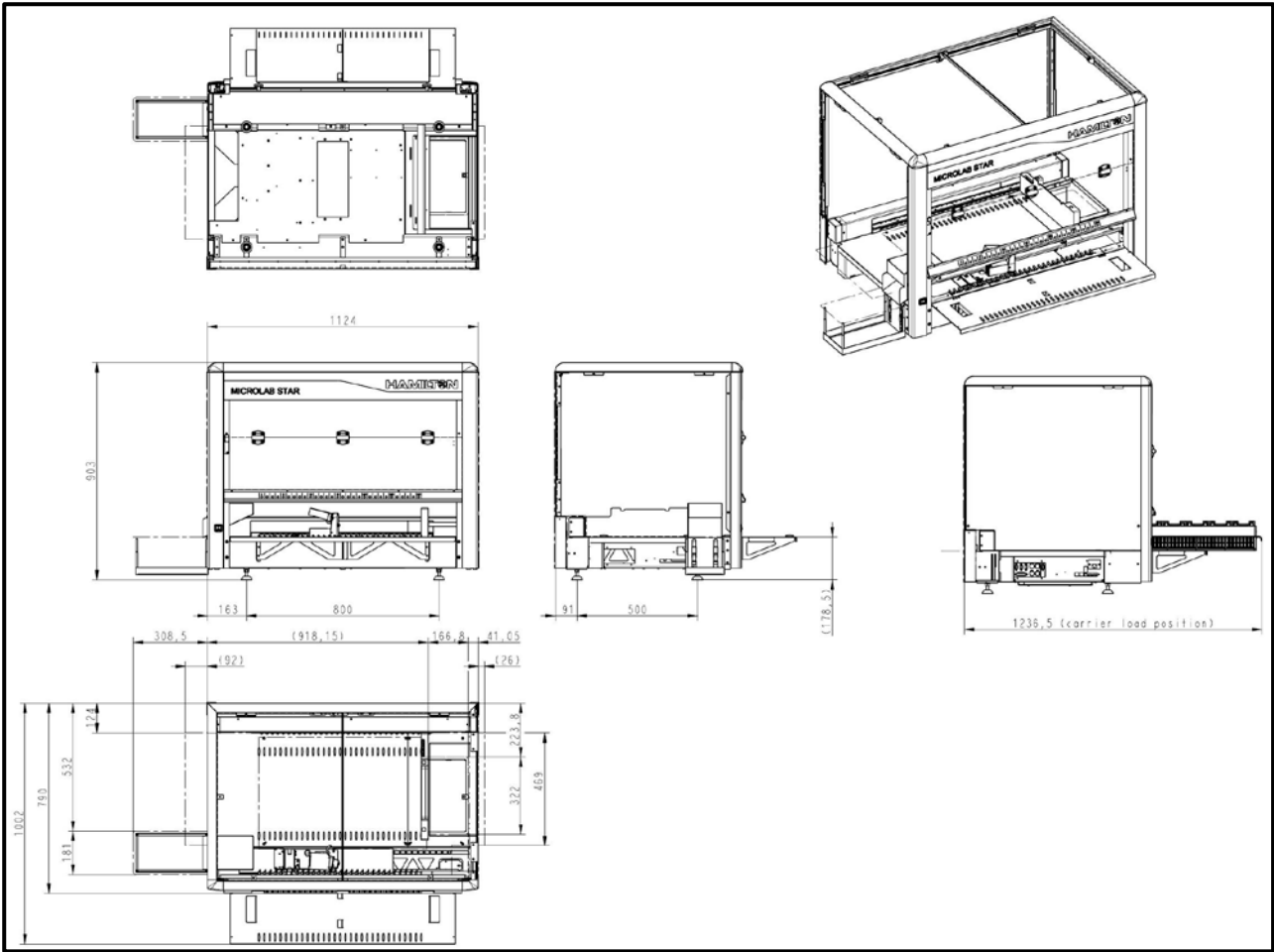

8.3.4 ML STARlet, on Bench with Doors and PC

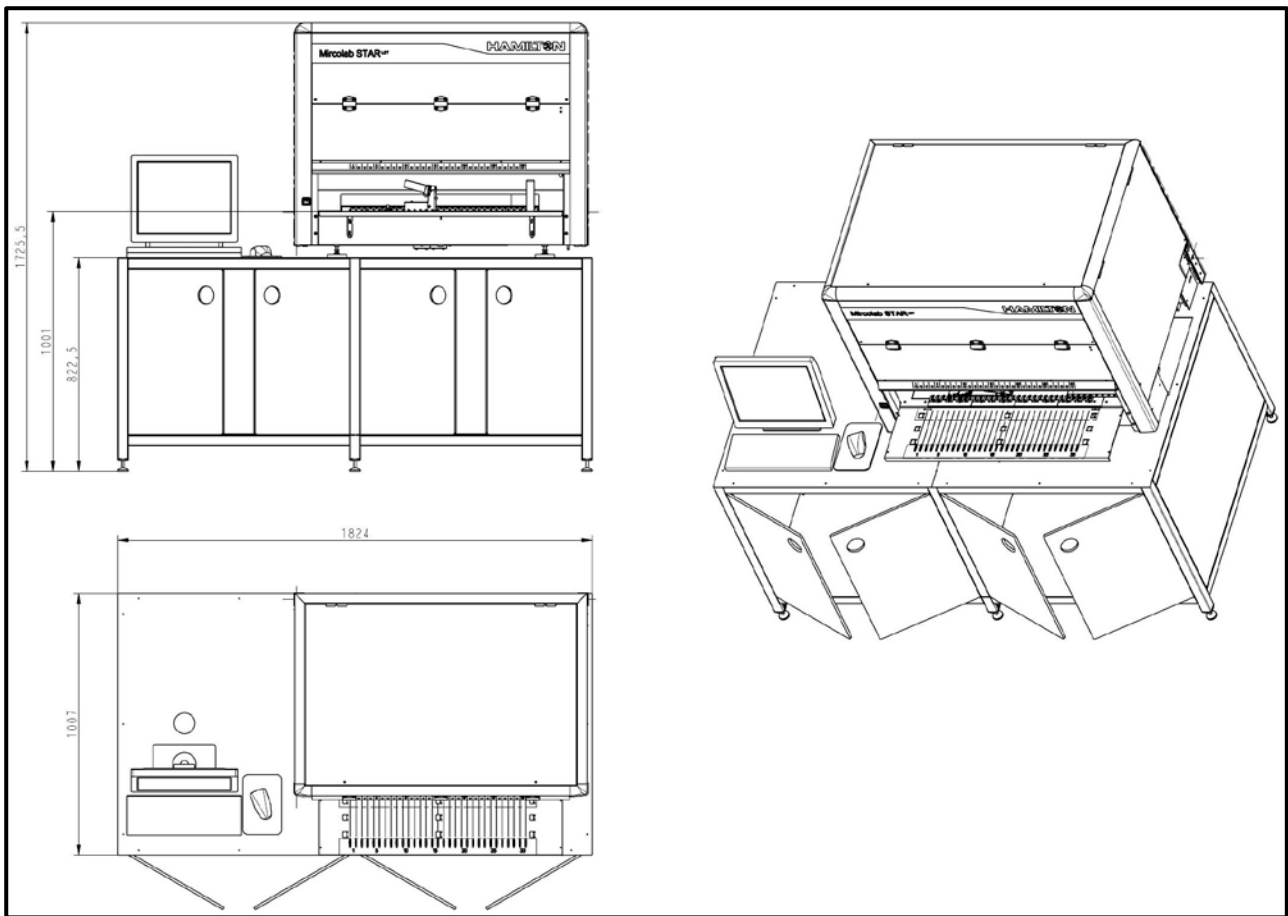

8.3.5 ML STARlet, on Table with PC

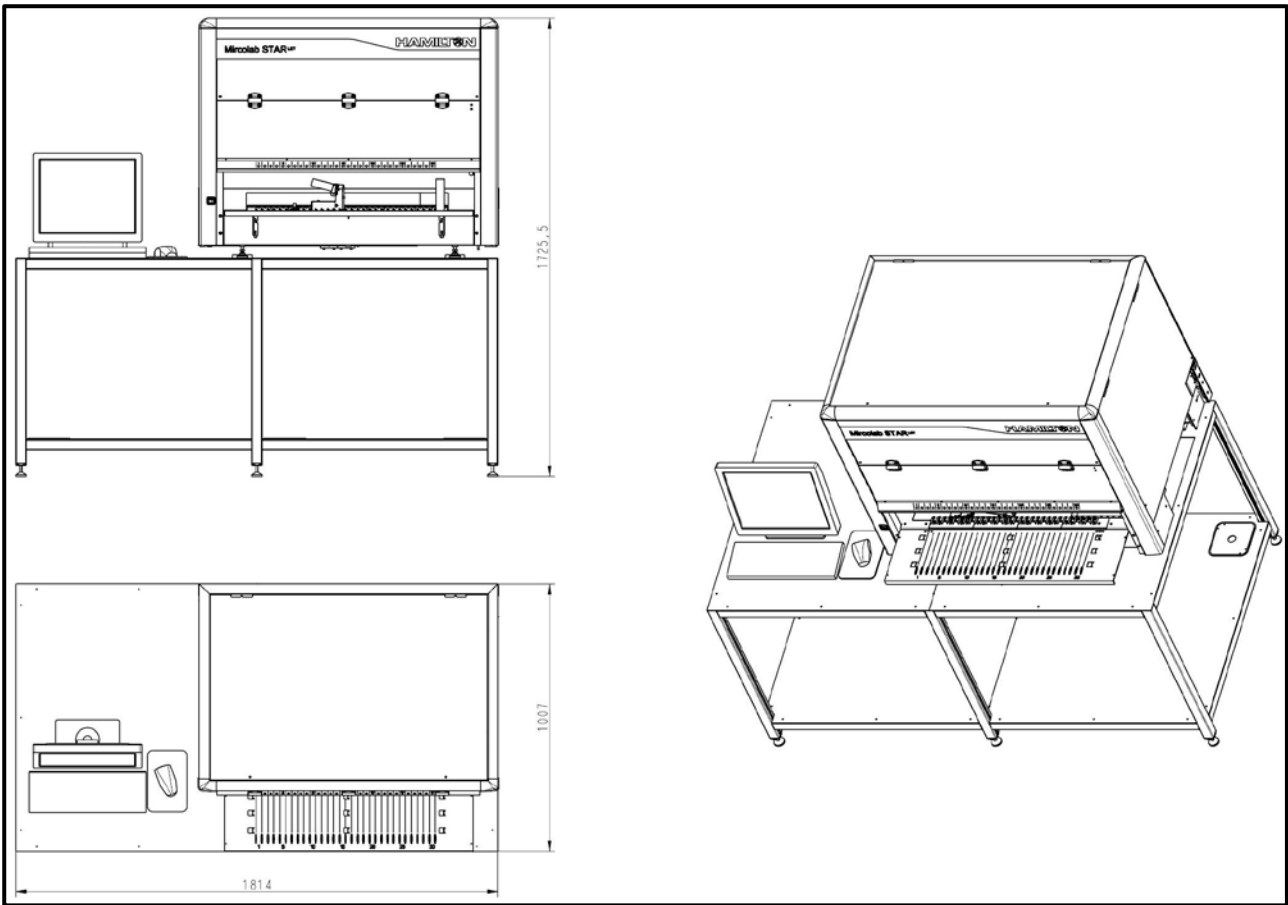

8.3.6 ML STAR, Manual Load

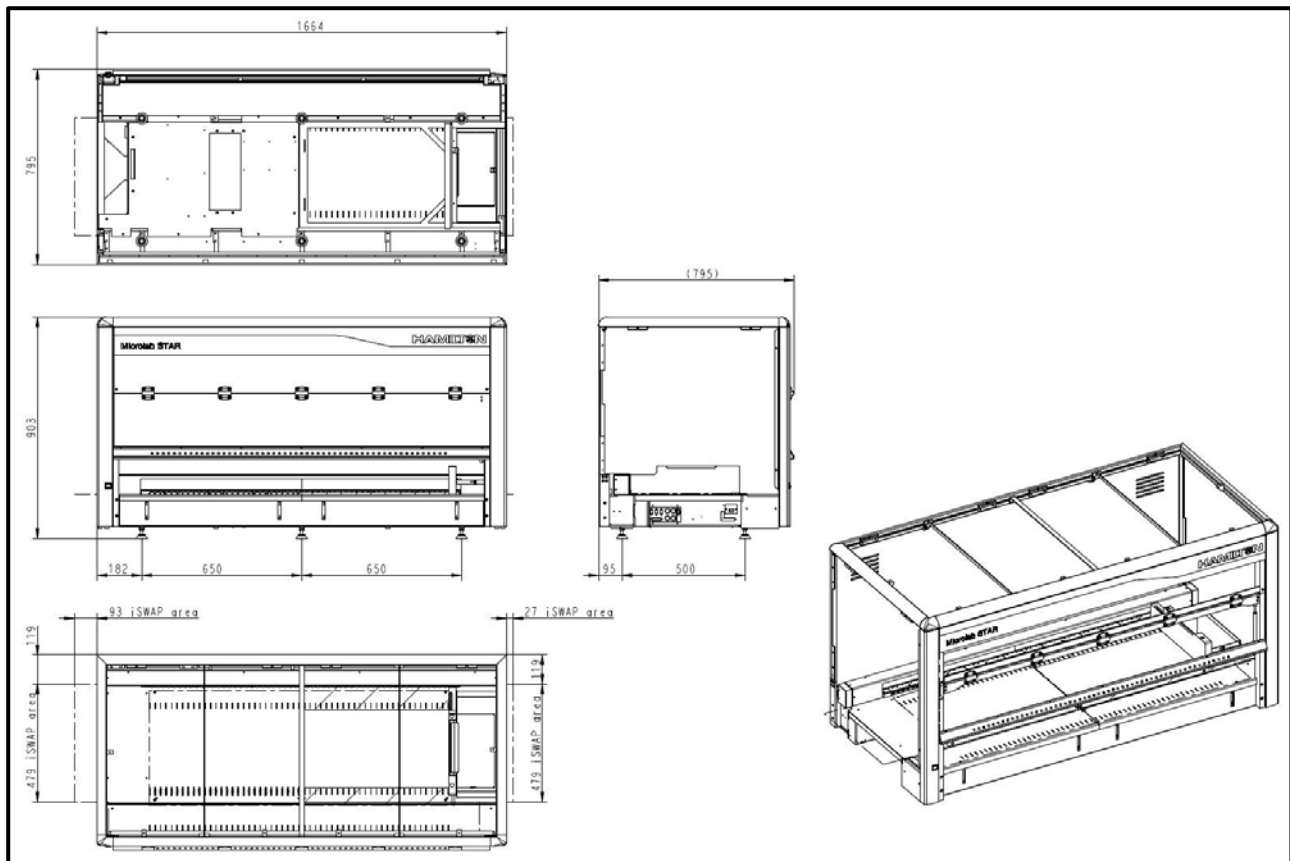

8.3.7 ML STAR, Manual Load, MPH

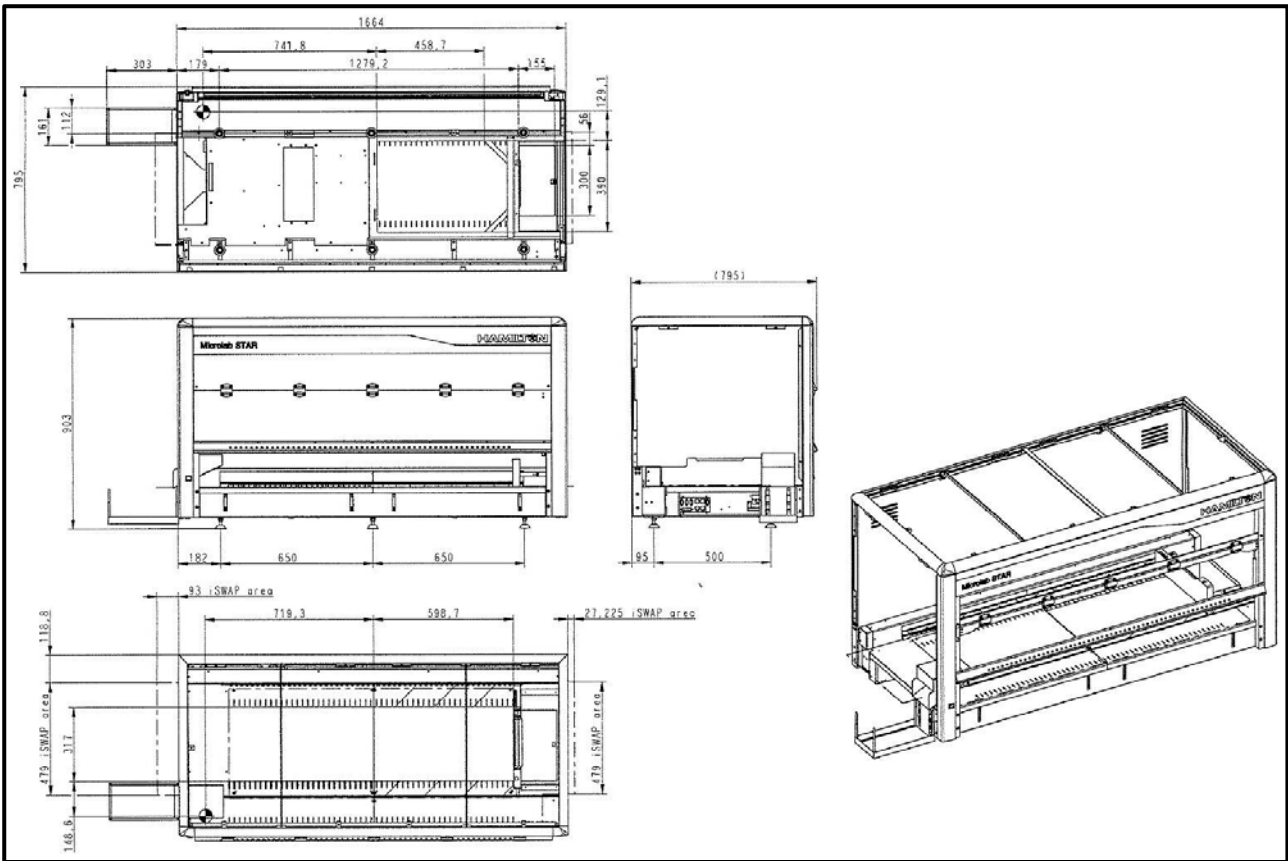

8.3.8 ML STAR, Manual Load with HEPA Hood

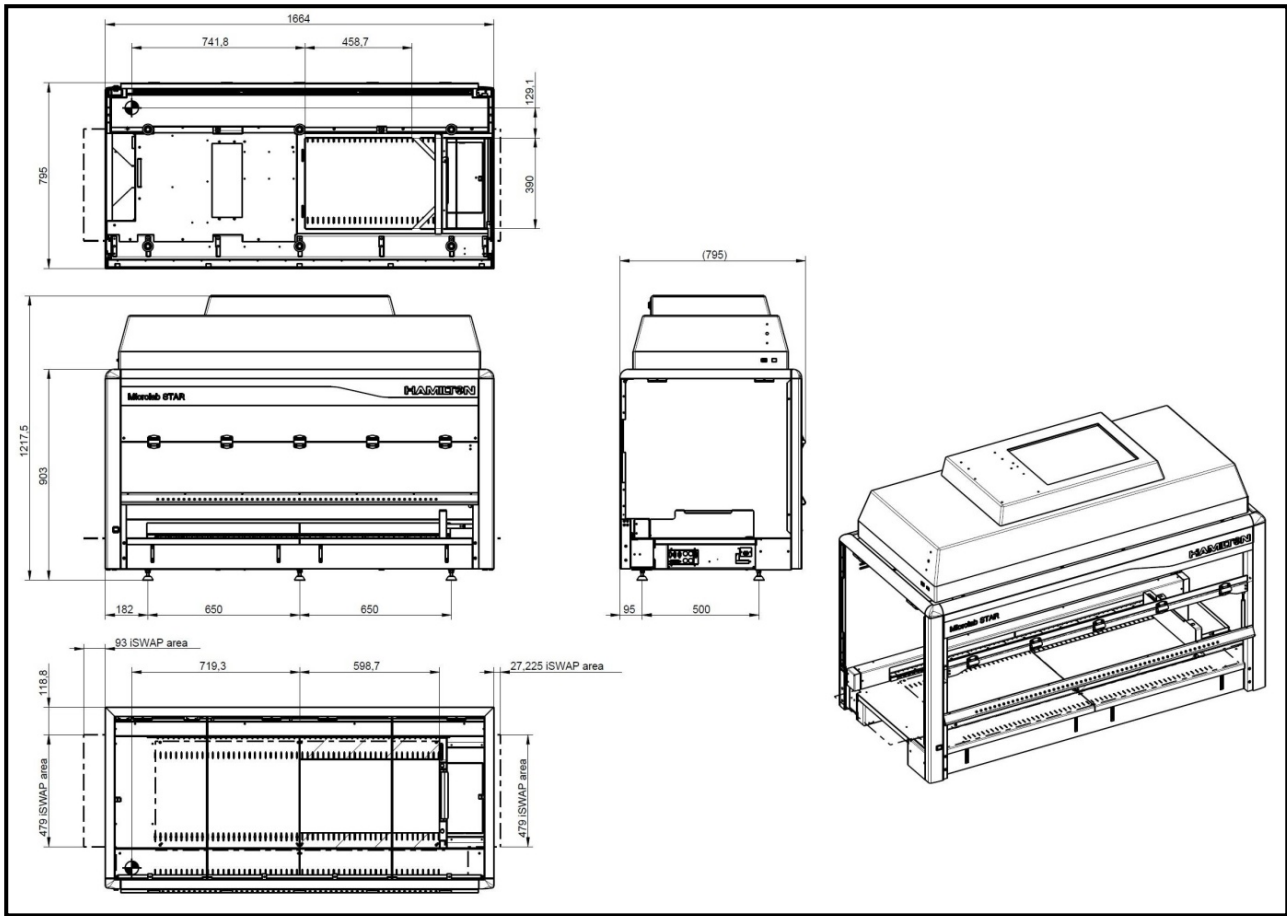

8.3.9 ML STAR, Autoload

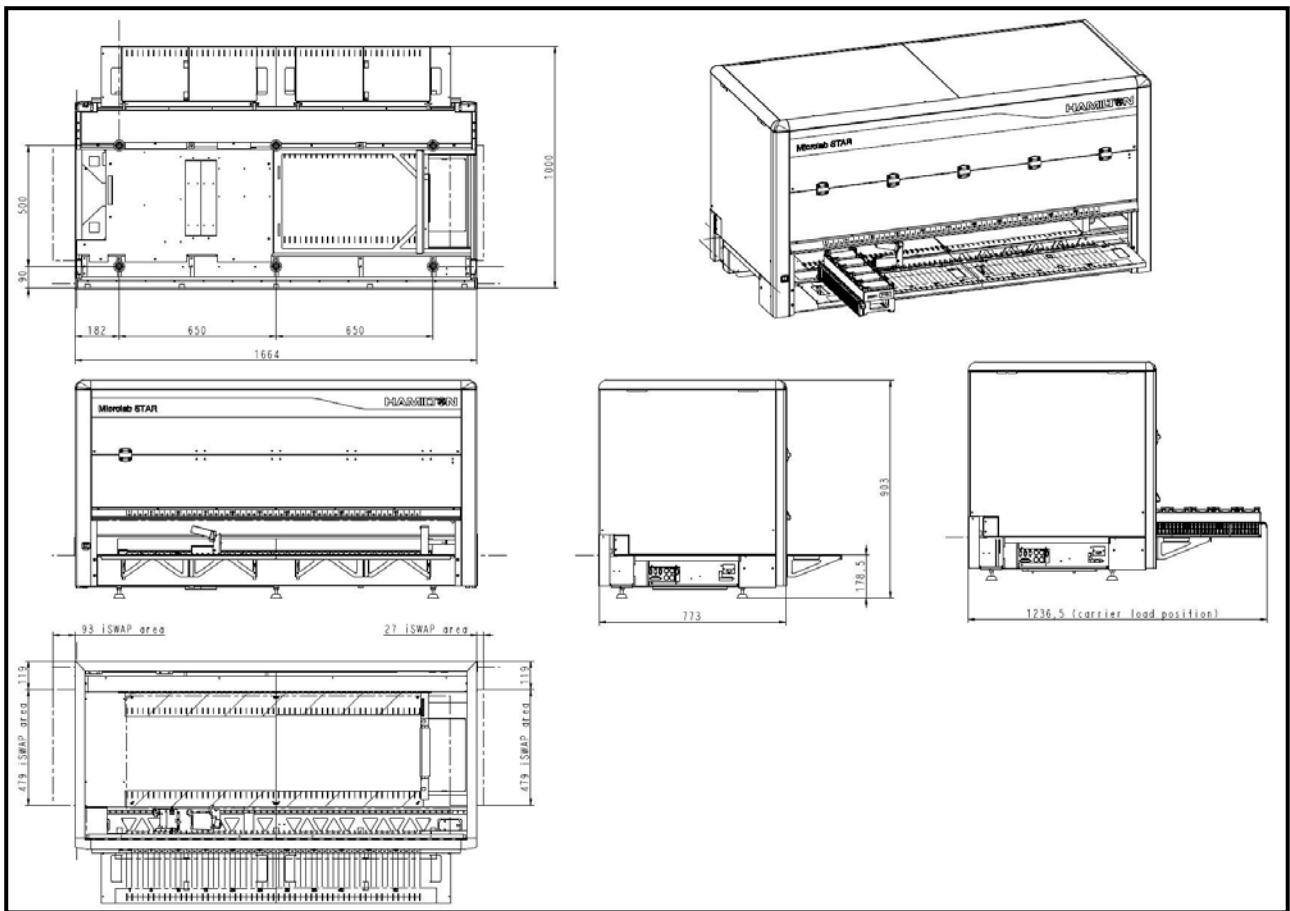

8.3.10 ML STAR, Autoload, Extension Housing Left

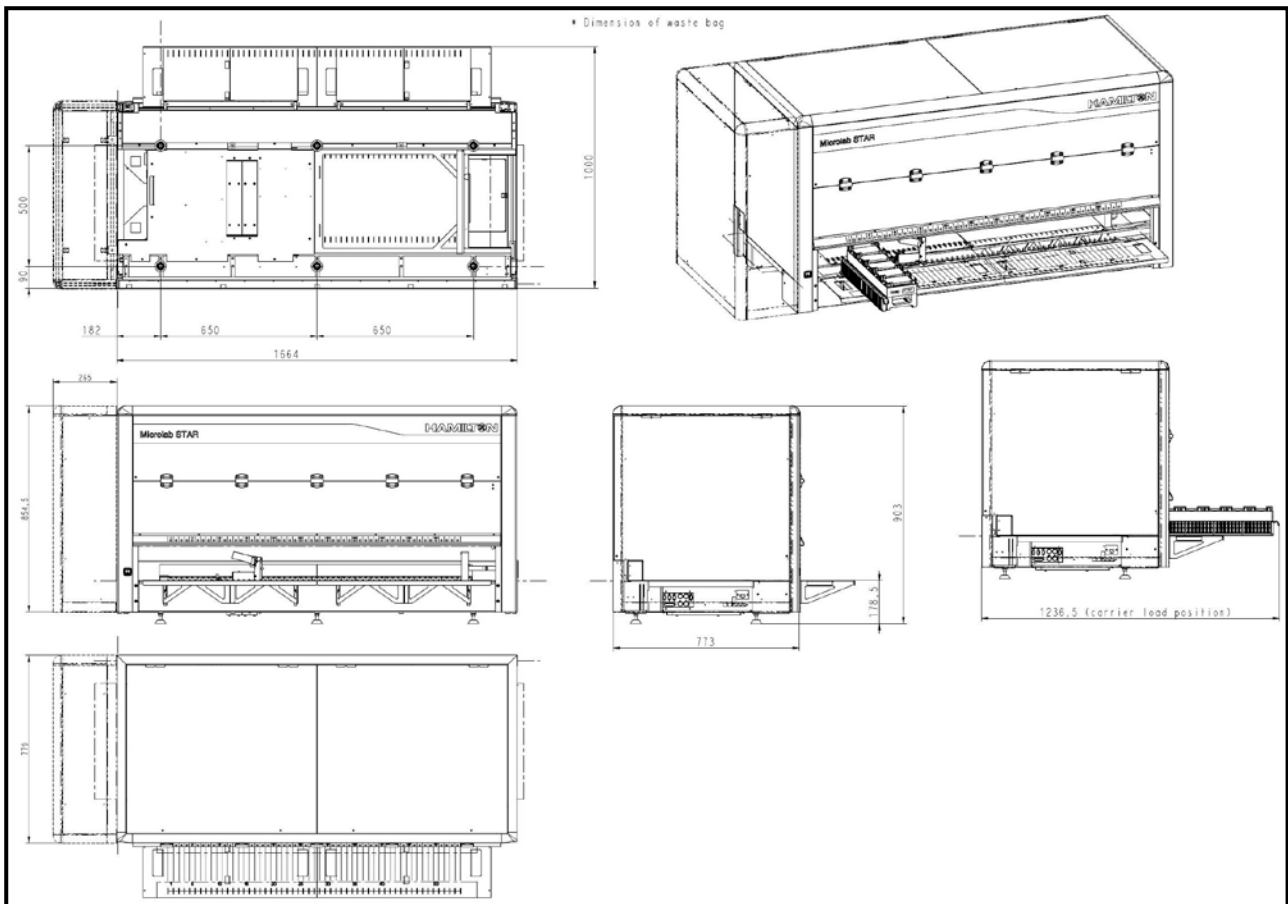

8.3.11 ML STARPlus, Manual Load, 30T

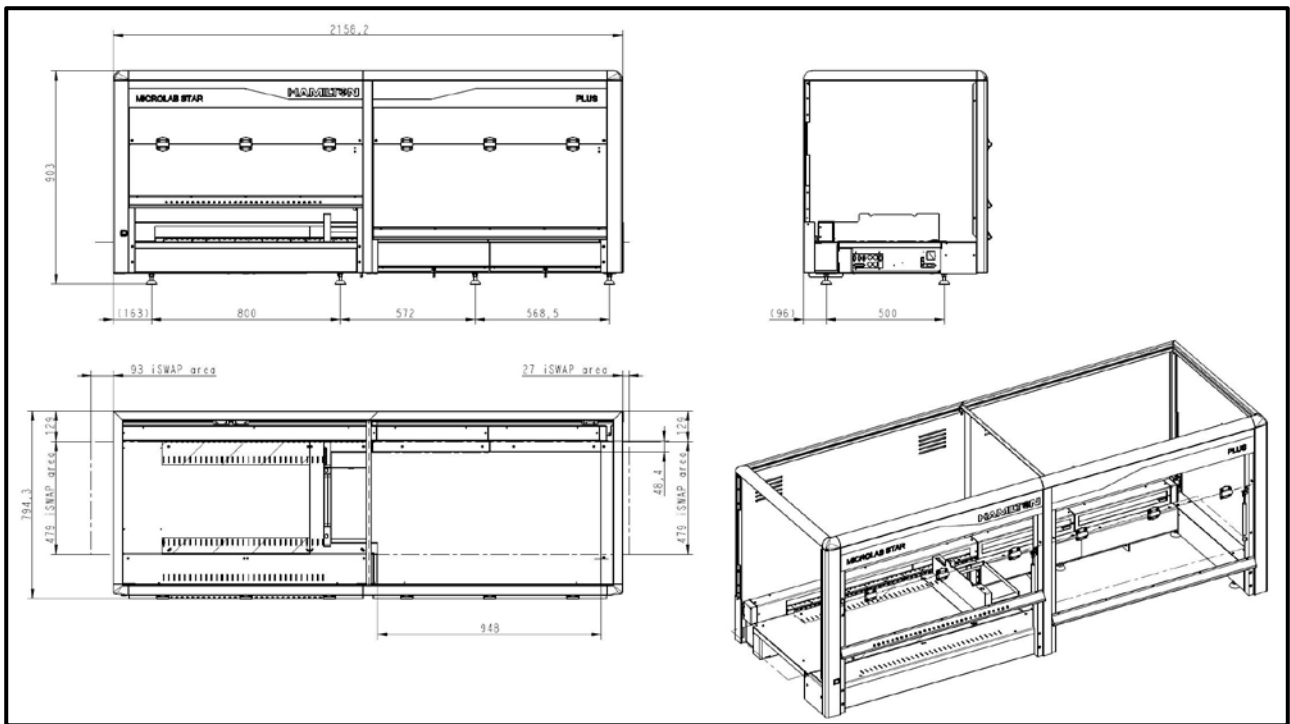

8.3.12 ML STARPlus, Manual Load, 50T

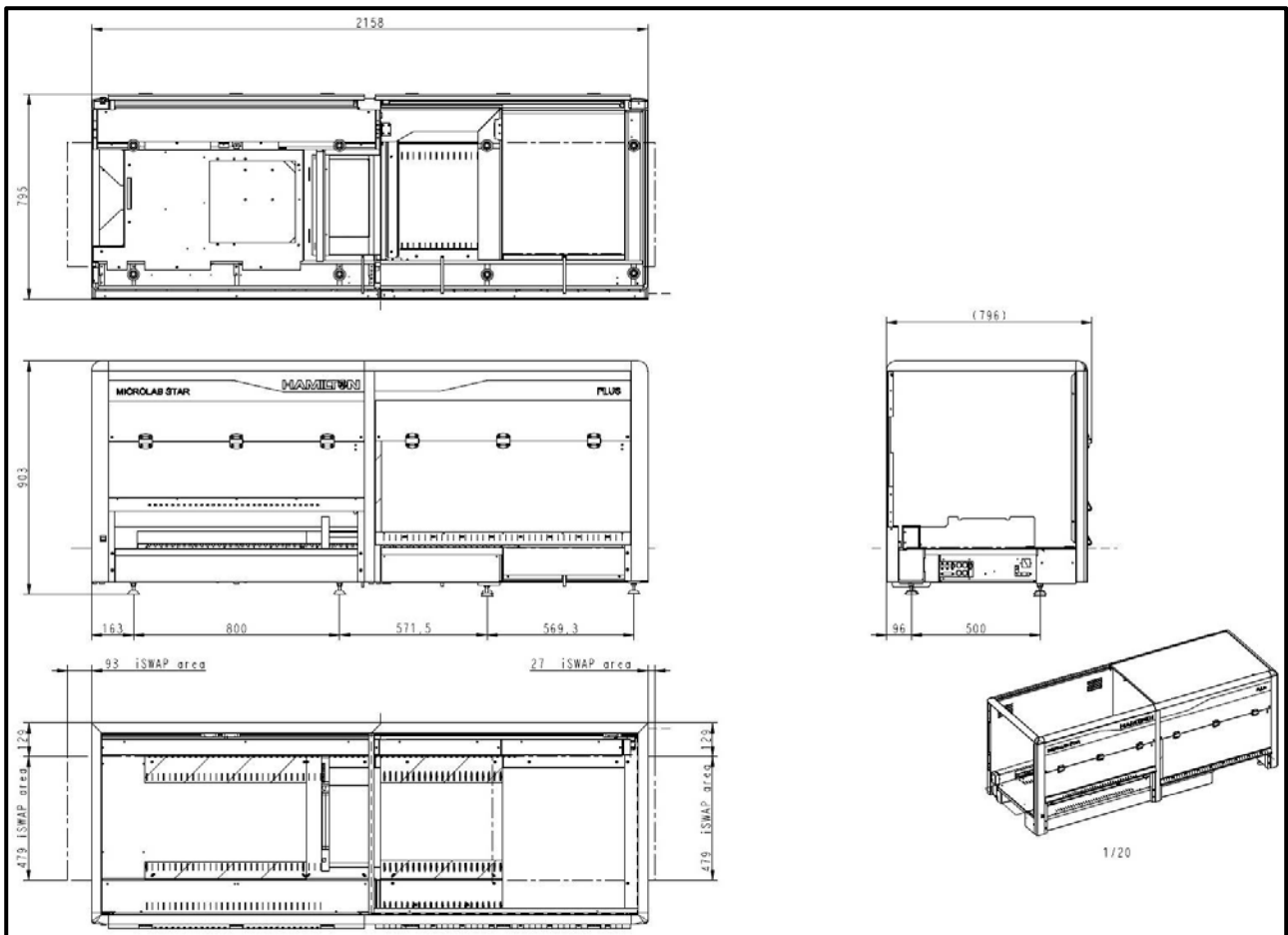

8.3.13 ML STARPlus, Manual Load, 71T

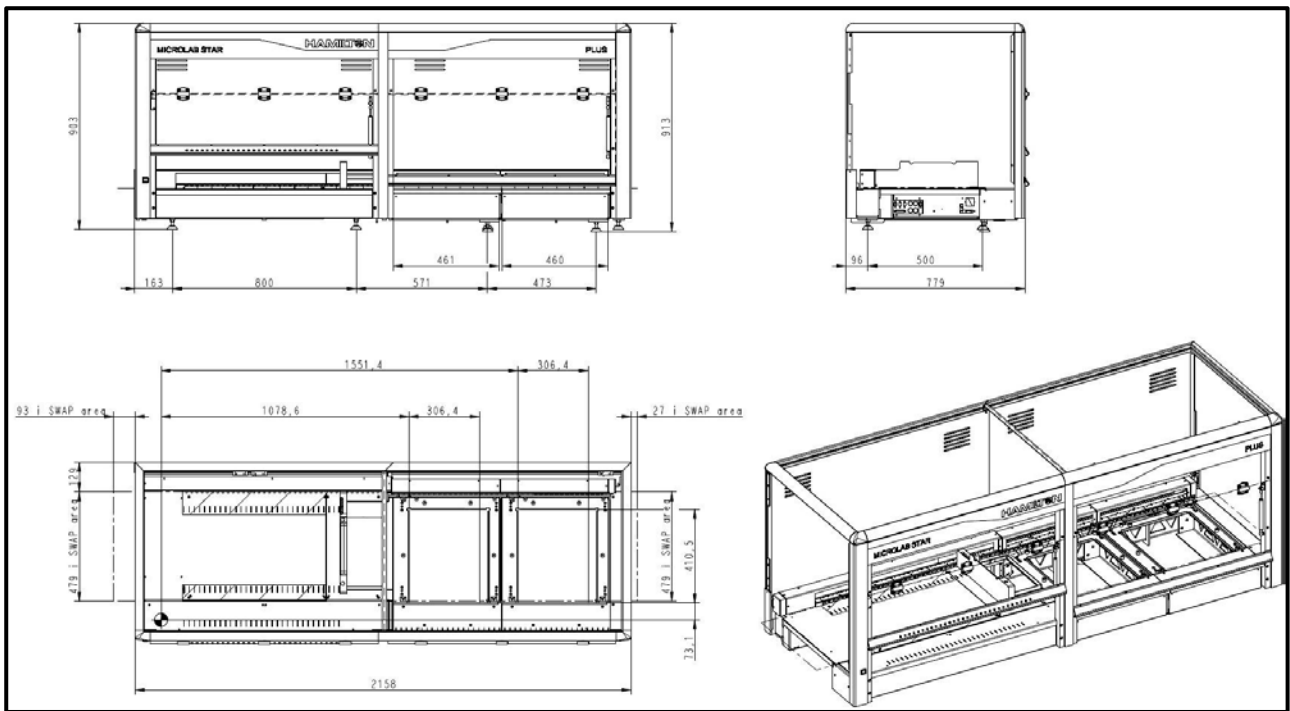

8.3.14 ML STARPlus, Autoload, 30T

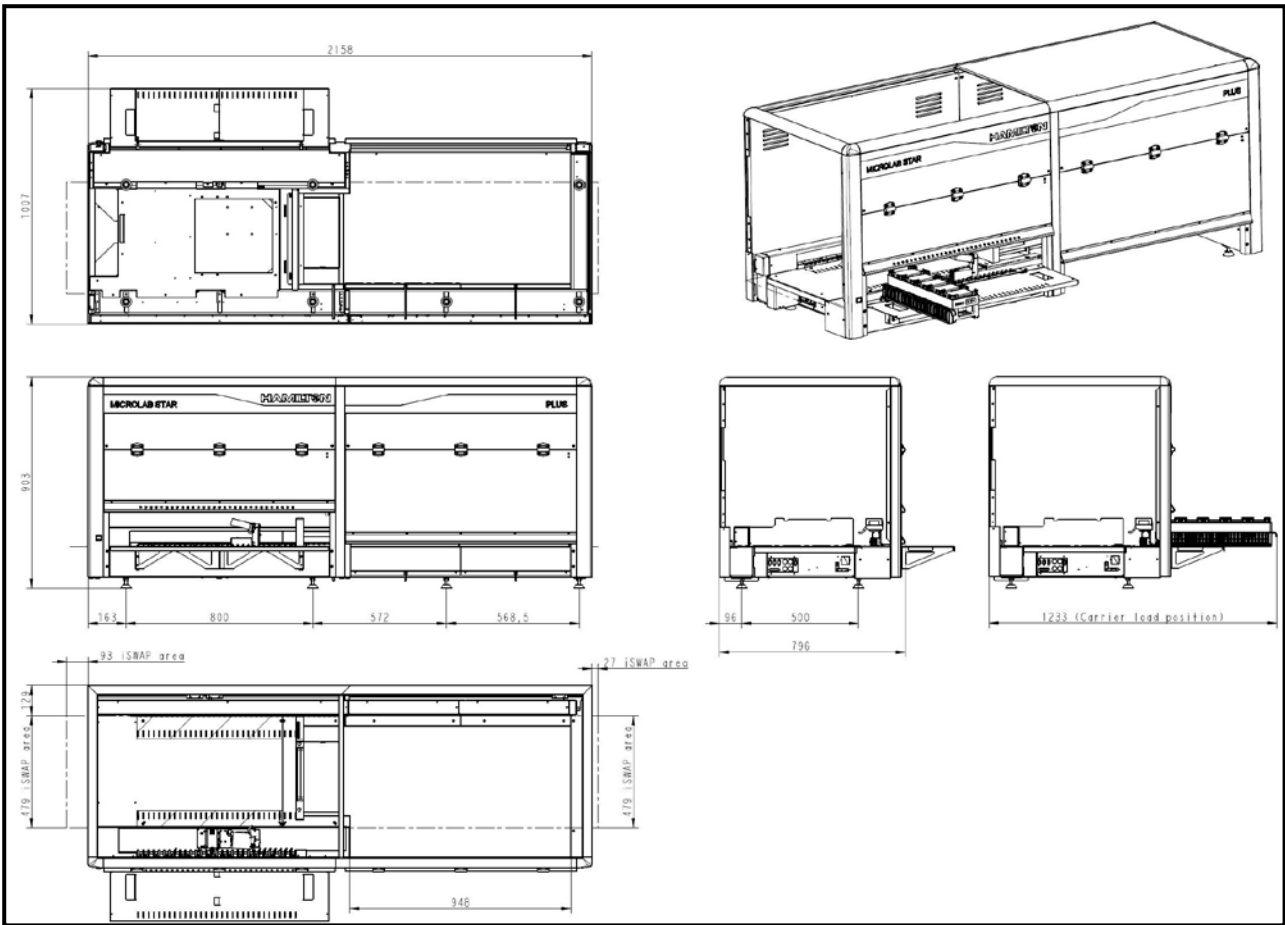

8.3.15 ML STARPlus, Autoload, 50T

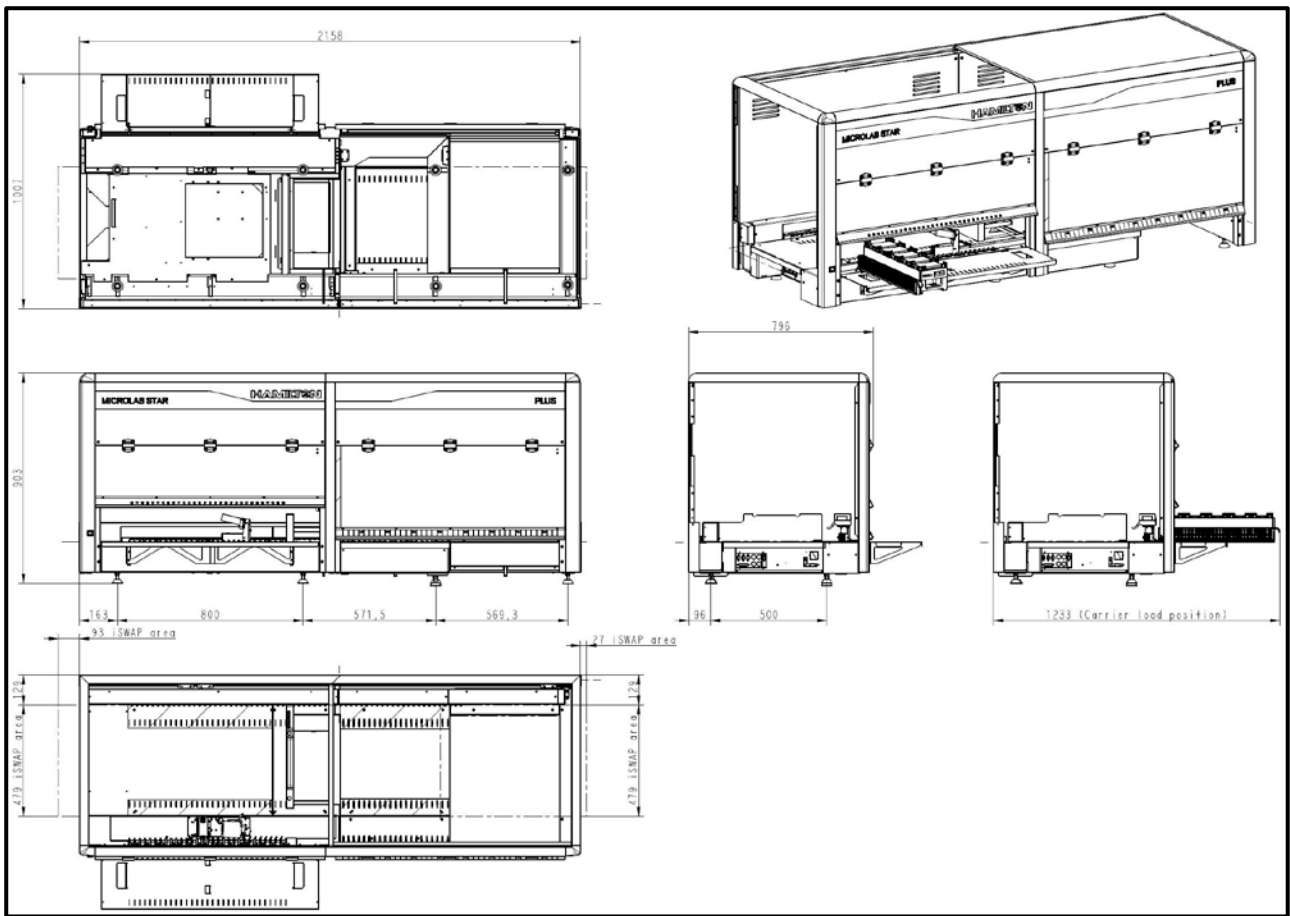

8.3.16 ML STARPlus, Autoload, 71T

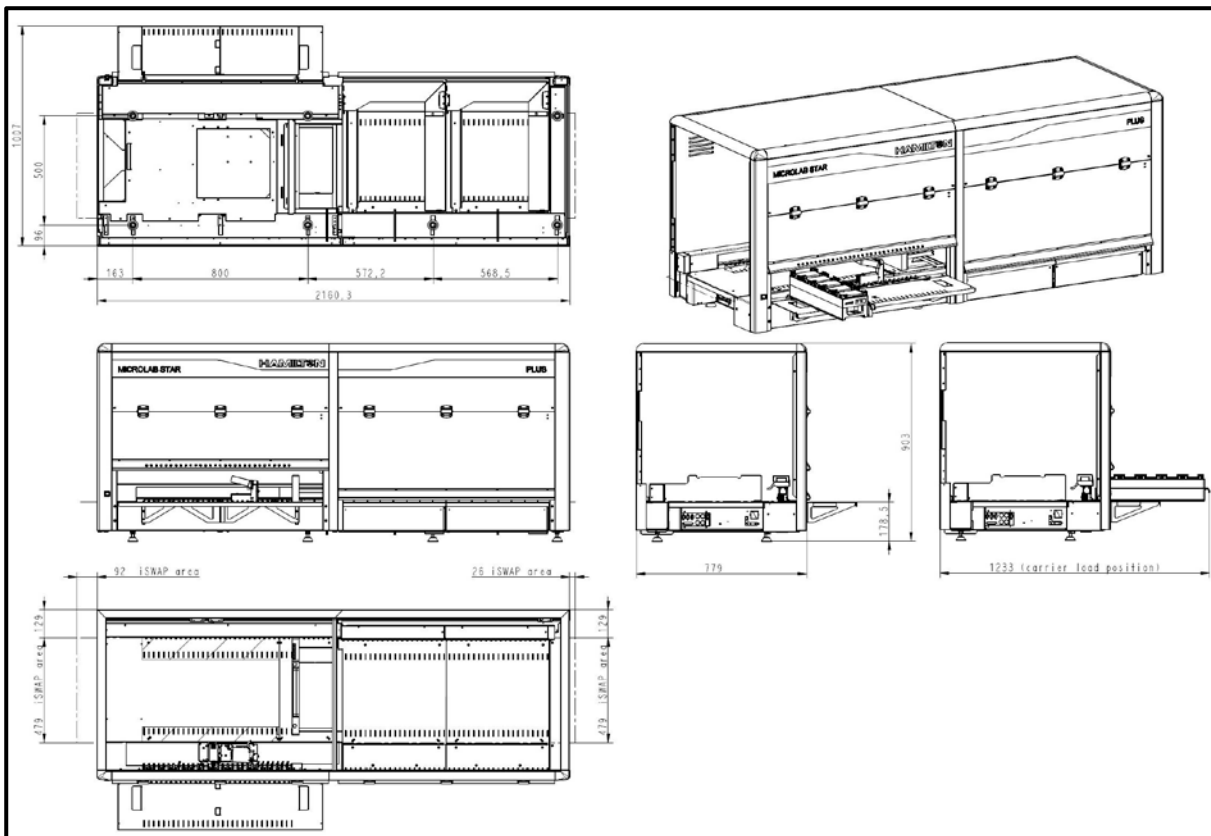

8.3.17 Chemagic STAR

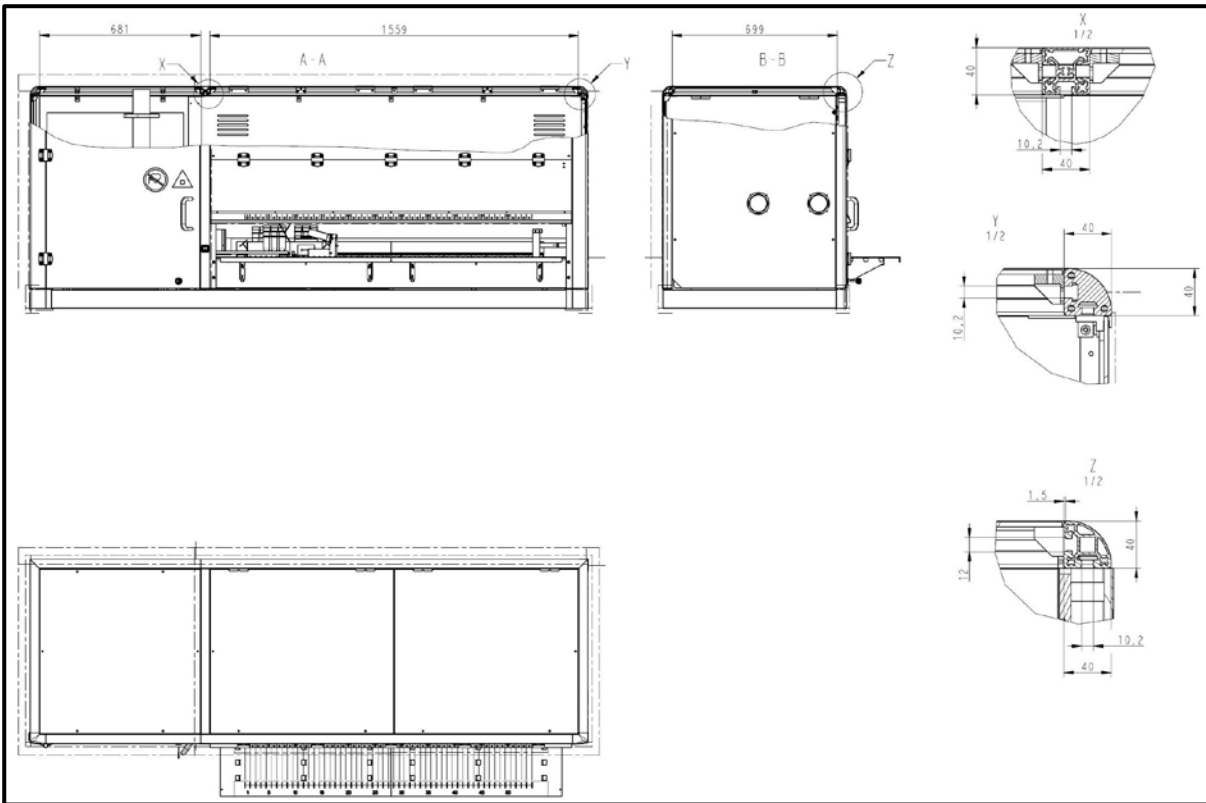

8.4 Appendix D: Regulatory Affairs

CE, CSA and UL conformity are maintained for the ML STAR. See the Declaration of Conformity for the instrument, reproduced on the next page.

8.4.1 Radio Interference (USA and Canada)

This equipment has been tested and found to comply with the limits for a Class “A” digital device, pursuant to both Part 15 of the FCC Rules and the radio interference regulations of the Canadian Department of Communications. These limits are designed to provide reasonable protection against harmful interference when the equipment is operated in a commercial environment. This equipment generates, uses and can radiate radio frequency energy and, if not installed and used in accordance with the present user manual, may cause harmful interference to radio communications. Operation of this equipment in a residential area is likely to cause harmful interference, in which case the user will be required to correct the interference at his own expense.

Pursuant to the Canadian Radio Interference Regulations, ICES-001 Notice for Industrial, Scientific and Medical Radio Frequency Generators, this ISM apparatus meets all requirements of the Canadian Interference-Causing Equipment Regulations. Please note that this requirement is only for generators which operate at over 10,000 Hz.

8.4.2 *In vitro* Diagnostics

The ML STAR is classified as a general laboratory instrument and not as an *in vitro* diagnostic device. There are ML STAR based instruments for *in vitro* diagnostic use.

The following text defines an *in vitro* diagnostic device [from: Directive 98/79/EC of the European Parliament and of the Council of 1998-10-27 on *in vitro* diagnostic medical devices]:

'[...] *in vitro* diagnostic medical device' means any medical device which is a reagent, product, calibrator, control material, kit, instrument, apparatus, equipment, or system, whether used alone or in combination, intended by the manufacturer to be used *in vitro* for the examination of specimens, including blood and tissue donations, derived from the human body, solely or principally for the purpose of providing information:

- Concerning a physiological or pathological state, or
- concerning a congenital abnormality, or
- to determine the safety and compatibility with potential recipients, or
- to monitor therapeutic measures.

Specimen receptacles are considered to be *in vitro* diagnostic medical devices. 'Specimen receptacles' are those devices, whether vacuum-type or not, specifically intended by their manufacturers for the primary containment and preservation of specimens derived from the human body for the purpose of *in vitro* diagnostic examination.

Products for general laboratory use are not *in vitro* diagnostic medical devices unless such products, in view of their characteristics, are specifically intended by their manufacturer to be used for *in vitro* diagnostic examinations; [...]

There are ML STAR based instruments for *in vitro* diagnostic use.

8.4.3 Applied Company Quality Management Systems

Applied company quality management systems EN ISO 9001 and EN ISO 13485 Certification Body is TÜV Rheinland LGA Products GmbH, Am Grauen Stein 29, D-51105 Köln-Poll, Germany.

8.4.4 Declaration of Conformity: CE, CSA

The following declarations are only templates. These templates will only be filled out according to the specifications after the order has been made.

Each individual instrument includes a Declaration of Conformity to European and American standards.

EU Declaration of Conformity

We Hamilton Bonaduz AG, CH-7402 Bonaduz/Switzerland confirm that the following product

Product name **Microlab STAR Line**
 Product type: Microlab STAR
 Microlab STARlet
 Microlab STARplus

S/N

meets the following EU directives (including all applicable amendments):

	Low Voltage Directive	2014/35/EU
	EMC Directive	2014/30/EU
	RoHS 2	2011/65/EU

Applied company quality management systems	Certification Body
EN ISO 9001	TÜV Rheinland LGA Products GmbH
EN ISO 13485	Am Grauen Stein 29
	D-51105 Köln-Poll, Germany

Applied standards:

Safety:	EN 61010-1	(2001)
	EN 61010-2-010	(2003)
	EN 61010-2-020	(2006)
	EN 61010-2-081	(2001) + A1 (2003)
	EN 60825-1	(2008)
EMC: Emission	EN 61326 -1	(2013) class B
Immunity	EN 61326 -1	(2013) Basic environment
Risk Management:	ISO 14971	(2012)

Additional Information:



Canada, USA

CAN/CSA-C22.2 No. 61010-1-04 & -2-010 & -2-020 & -2-081
 UL Std. No. 61010-1 (2nd Edition)
 FCC, Part 15, class A

Authorize department for technical documents:

HAMILTON Quality Department Robotics

Hamilton Bonaduz AG

Andreas Wieland
 CEO

Bonaduz, 10.8.2016

608399/08

HAMILTON Bonaduz AG
 Via Crusch 8
 CH-7402 Bonaduz/Switzerland
www.hamiltoncompany.com

1 / 1

8.4.5 Declaration of Quality

The following declarations are only templates. These templates will only be filled out according to the specifications after the order has been made.

Declaration of Quality

We Hamilton Bonaduz AG, CH-7402 Bonaduz/Switzerland confirm that the following product passed the manufacturer's final inspection and was within specifications.

Product: **Microlab STAR Line**

Product type: Microlab STAR 16 channel
 Microlab STARlet 16 channel
 Microlab STARplus 16 channel

S/N

The following dosage specifications have been measured:

Test No	Test volume [µl]	Tip size [µl]	No of measurements per channel	Standard deviation [µl]	Precision [%]	
					Spec.	Actual
1	2	10	10	< 6.0
2	5	10	10	< 2.0
3	10	300	10	< 2.5
4	100	300	10	< 1.0

8.4.6 WEEE Declaration

8.4.6.1 Recycling of a Hamilton ML STAR Instrument

Recycling of a Hamilton's ML STAR Line Instruments in accordance to EC directive WEEE

The European Community requires from manufacturers to organize the disposal and waste of electrical and electronic equipment (WEEE). For this reason, Hamilton Bonaduz AG took part in an initiative to organize the disposal of ML STAR products through a European disposal network called RENE. RENE is the largest recycling network for the disposal of electronic equipment in Europe. The mission of RENE is a European-wide, WEEE-compliant, high quality recycling for electrical and electronic equipment through a dense network with both innovative and SMB-sized partner companies. As a result, Hamilton Bonaduz AG gets a turn-key-solution that includes all processes from treatment of incoming orders over collection, logistics and recycling down to reporting and management of material flows.

Hamilton offers a WEEE process in collaboration with Toolpoint and RENE AG:

- Request for the collection of the Hamilton instrument via Toolpoint Home Page (www.toolpoint.ch)
- Completion of the decontamination confirmation form
- Preparation for transport: packing
- Activation of the recycling order
- Archiving of the decontamination confirmation
- Disposal of the instrument

Responsibilities	
Ordering party	Decontamination Preparation for transport Note: The cost for decontamination and preparation for shipment is paid by the ordering party. On request, HAMILTON offers to take care for that part of the recycling process.
RENE	Transport Disposal
Toolpoint	Registration Invoice the disposal to HAMILTON
HAMILTON	Organize the disposal according to the WEEE directive

8.4.6.2 Recycling Process

1. Request for disposal of the instrument

Access to the order registration is given by the Toolpoint homepage www.toolpoint.ch

Recycling Order registration form

2. Completion of the Decontamination form

Once the form has been completed, the request for disposal is automatically activated and transferred to Toolpoint. The confirmation of the order will be sent to the registered contact person.

3. Decontamination

The responsibility for decontamination remains at the ordering party. It is mandatory to sign the decontamination form and send a copy electronically to Toolpoint. Toolpoint forwards the documentation to RENE, who is in charge of instrument disposal.

4. Packing / Preparation for shipment

For the transportation of instruments with a weight of over 30kg need to be fixed on a euro pallet. Instruments below 30kg can be packed in a cardboard or plastic box. A signed copy of the decontamination form needs to be added to the outer part of the shipping box or instrument.

Refer to the Technical Note "Recycling of a Hamilton's ML STAR Line Instruments in accordance to EC directive WEEE".

8.4.7 RoHS Compliance

Since June 2011 ML STAR Line instruments are in compliance with RoHS Directive 2002/95/EC of the European Parliament and of the Council of 27 January 2003, on the restriction of the use of certain hazardous substances in electrical and electronic equipment (RoHS) and its amendments.

Since July 2016 ML STAR Line instruments are in compliance with RoHS II Directive 2011/65/EU of the European Parliament and of the Council of 8 June 2011, on the restriction of the use of certain hazardous substances in electrical and electronic equipment (RoHS II) and its amendments.

8.4.8 21 CFR Part 11 Compliance

The FDA issued regulations covering agency criteria for maintenance, security and submittal of electronic records by publication of Final Rule 21 CFR Part 11 Electronic Records; Electronic Signatures in the Federal Register of March 20, 1997. Laboratory implementation and compliance with the 21 CFR Part 11 regulation requires a program combining GLP (Good Laboratory Practice) with compliant instrument software and secure LIMS database management. Hamilton's Vector/VENUS software contains the tools necessary for 21 CFR Part 11 compliant operation of the Microlab robotic instruments (shown on the back of this document). This section describes the specific features of the Microlab Vector / VENUS software enabling compliant instrument operation along with areas of laboratory responsibility.

Requirements	Vector/VENUS Software	21 CFR Part 11.10 Section
Controlled system access	Microlab Vector/VENUS uses the security tools provided in Windows 7 or Windows 10 for five defined user groups Vector/VENUS functional protections	a, d d, g
Files accessible and printable in a human readable form	Files can either be printed as text or from the correct viewer	b
Electronic records must be protected and maintained throughout the records retention period	User id and date/time stamps are applied to every electronic record when it is saved Changes to records are monitored by checksum Hamilton maintains backward compatibility when reasonable Vector/VENUS is compatible with database software programs for version control for complete audit trails	g g b, c e
Documentation	Hamilton documentation for robotic instruments are controlled through an ISO-9001 compliant change control process consistent with 21 CFR Part 11 regulation	k (1)
Training	Hamilton provides ISO-9001- compliant training with certification of training for users	i

Summary of Microlab Vector/VENUS software compliance. The sub-sections of 21 CFR Part 11.10 are addressed individually below. The letters in the third column refer to the sub-section relating to each point.

A. What do I need to do to be 21 CFR Part 11 compliant with my Hamilton ML STAR instrument and Vector/VENUS software?

1. Define Windows user groups and assign users to the groups with unique user id/passwords. Define accessible directories for the user groups along with privileges in those directories, such as read-only or full access.

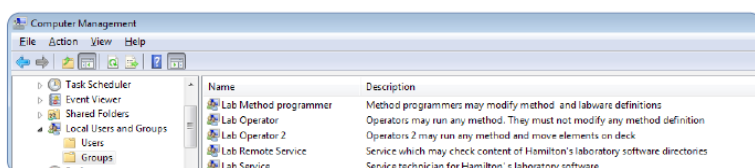

Windows environment for defining user groups and adding users to the groups.

The Windows operating systems have security tools to restrict user access to desktops and directories by user id/password protection and user group definitions. Each user group is given different access and privilege to Hamilton files as is appropriate for their functions. Methods can be protected by Windows tools by saving all validated methods in limited-access directories, while saving non-validated methods in other restricted directories. Low level users can be allowed to access the directory with validated methods while blocking these user groups from the non-validated methods directory. Barcode and worklist files are not protected by Vector/VENUS software. These files may be created and used by programs outside of Hamilton's control. Further protection of these files for full compliance must be accomplished by laboratory practices.

2. Enable the function protections in Vector/VENUS software. When these protections are enabled, Vector/VENUS checks the user group of the logged in user and allows functional privileges based on the user group.

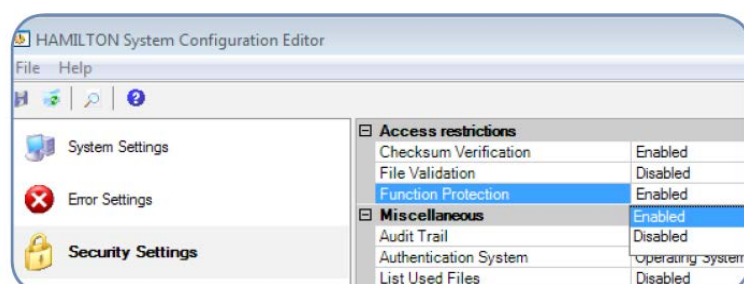

Environment for enabling Vector/VENUS function protection.

The function protection in Vector/VENUS, along with the user groups established in Windows, provide authority-based access to the software for user level authentication and access. Additionally, all files are protected by checksum and are date/time stamped with the user id when the files are saved or created.

3. Define the SOPs and practices for complete laboratory compliance. Laboratories are responsible for defining SOPs for reaching full compliance when using Vector/VENUS software with Hamilton instrumentation. These SOPs include:
 - Maintaining archives of old methods and software revisions throughout the records maintenance period
 - Implementing practices or additional software sufficient for a complete audit trail of records
 - Maintaining internal documentation on any Hamilton instrumentation

Recommendations for necessary SOPs are addressed inside.

B. Hamilton Electronic Records

Operation of a Hamilton instrument involves multiple file types or electronic records, which need to be protected under 21 CFR Part 11. These files are either input to be used during the method development and runtime or output files, which are created by the software during runtime.

Input Files:

- Labware Definitions
- Liquid Class Definitions
- Method Files
- System configuration files

Output Files:

- Trace files

Barcode and worklist files are not protected by Vector/VENUS software. These files may be created and used by programs outside of Hamilton's control. Further protection of these files for full compliance must be accomplished by laboratory practices.

C. Controls for Closed Systems

Hamilton robotic instruments are controlled by closed computer systems. A closed system is one to which access is controlled by persons responsible for the content of the electronic records on that system. Below each section of 21 CFR Part 11.10 is followed by an explanation of Hamilton's Vector/VENUS software compliance approach and the implementation responsibilities of the end user.

Controls for Closed Systems - 21 CFR Part 11.10

Persons who use closed systems to create, modify, maintain, or transmit electronic records shall employ procedures and controls designed to ensure the authenticity, integrity, and when appropriate, the confidentiality of electronic records, and to ensure that the signer cannot readily repudiate the signed record as not genuine. Such procedures and controls shall include the following:

This section describes the requirements to define an electronic record as protected for closed systems. This applies to all records created on a closed system, whether or not it is validated or formally recognized by the organization. The following sections address more specific requirements.

Validation - 21 CFR Part 11.10 (a)

Validation of systems to ensure accuracy, reliability, consistent intended performance, and the ability to discern invalid or altered records.

This refers to the validation of the electronic signature system to be used. The electronic signature system must be able to restrict access to various levels of functionality, identify when a change is made to an electronic record, by whom, and whether these changes were validated. Microlab Vector/VENUS software uses the security tools of the Windows 7 or Windows 10 operating system. This system allows for different user groups within an organization to have different levels of access to the software. The files are user id and date/time stamped whenever they are saved. In addition, these files are checksum protected which protects files from inappropriate modification.

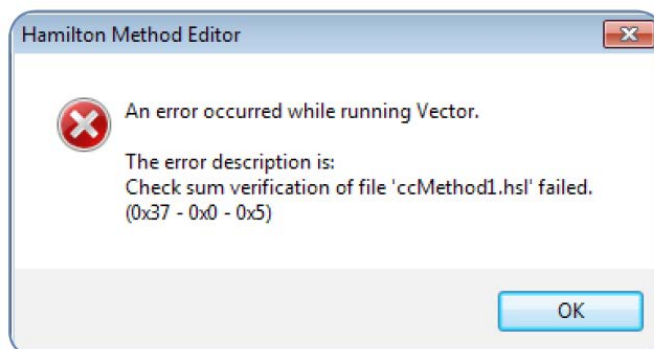

Error message seen when a checksum-protected file has been inappropriately modified. This message will appear when the user attempts to reopen the file

Readability - 21 CFR Part 11.10 (b)

The ability to generate accurate and complete copies of records in both human readable and electronic form suitable for inspection, review, and copying by the agency.

All records must be readily generated in either electronic or human readable form, along with the procedures used to create the records. This means all trace files must be retrievable along with the method files used to create these trace files (Figure 5). Organizations need to maintain electronic records as defined by agency-defined retention periods. Obsolete hardware and software versions do not need to be maintained, as long as all the records are retrievable with the change in technologies.

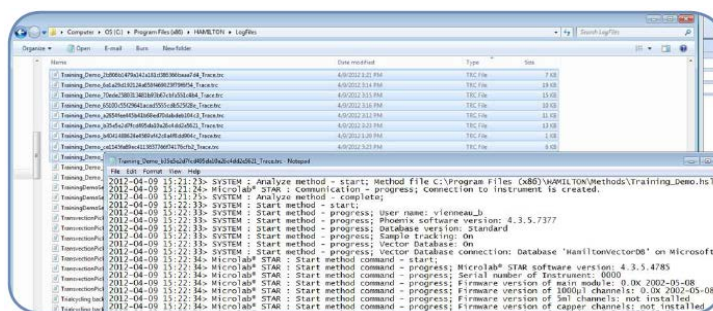

A trace file (.trc) documenting run time events for a particular method. A unique trace file is generated for each run time event with date/time and user id information located at the end of the file.

Vector/VENUS software files are either binary or ASCII text. ASCII is easily printed in human readable form with a text program. Other file types can be viewed and printed with the correct viewer or converted to ASCII and printed. Hamilton maintains backward compatibility of method files between software revisions when reasonable. In the event a software revision no longer supports an archived method, the appropriate software version must be maintained to support the archived record.

Archived Record Protection - 21 CFR Part 11.10 (c)

Protection of records to enable their accurate and ready retrieval throughout the records retention period.

This is similar to the above section requiring maintained electronic files throughout the data retention period. However, this rule is not limited to retrieval of data. The method must be able to be processed as originally done. Hamilton maintains backward compatibility of method files between software revisions when reasonable. Even if the current software version on the instrument does not support the archived method, records associated with the archived methods can still be viewed and are protected.

System Security - 21 CFR Part 11.10 (d)

Limiting system access to authorized individuals.

System access can be limited by current bilateral identification systems, such as user id and passwords, and/or by a single biometric identification. User access must be defined and limited to various levels of the software. This security can be applied through Windows 7 or Windows 10 security tools.

System access for Vector/VENUS software is controlled through the Windows 7 or Windows 10 operating system. Software allows access to various levels of the software based on the user group membership of the logged in user. If a user with an insufficient access level attempts to enter restricted sections of the software, an error message is displayed and the user is blocked from inappropriate access.

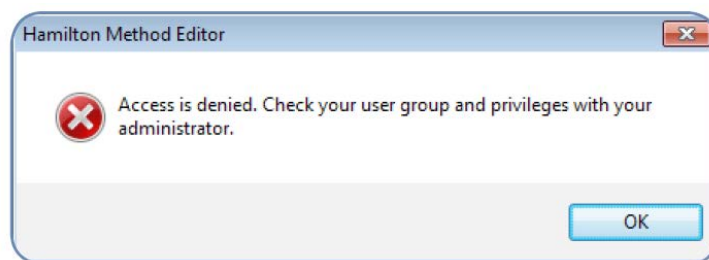

Error message shown when a user with insufficient access attempts to open a restricted file or directory.

Audit Trail - 21 CFR Part 11.10 (e)

Use of secure, computer-generated time-stamped audit trails to independently record the date and time of operator entries and actions that create, modify or delete electronic records. Record changes shall not obscure previously recorded information. Such audit trail documentation shall be retained for a period at least as long as that required for the subject electronic records shall be available for agency review and copying.

Complete audit trail documentation is outside the scope of Vector/VENUS software and must be maintained by laboratory practices.

Sequencing - 21 CFR Part 11.10 (f)

Use of operational system checks to enforce permitted sequencing of steps and events, as appropriate.

The purpose of operational system checks is to verify that operations are not performed out of sequence as defined by the method. It is the agency's intent that such checks be performed by the computer system. Method checkpoints can be written into the program to direct the user and ensure that certain events have taken place before continuing with the method, such as all labware being in position. However, fulfilling this is a laboratory procedure and is not enforced within the Vector/VENUS software.

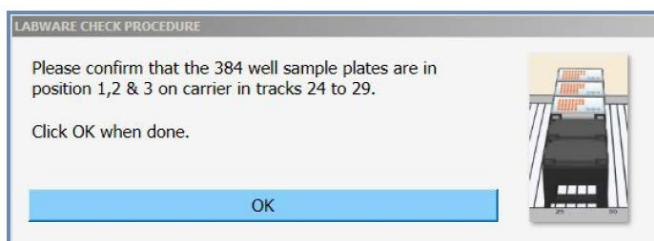

Messages to the operator can be programmed into the method to guide the operator in the correct sequence of events.

Authority - 21 CFR Part 11.10 (g)

Use of authority checks to ensure that only authorized individuals can use the system, electronically sign a record, access the operation or computer system input or output device, alter a record, or perform the operation at hand.

Five user groups have been defined and each group has a distinct level of access to the Vector/VENUS software (see table below). Methods can be controlled by saving validated methods in an access-controlled directory. Lab Operator and Lab Operator 2 user groups should be denied access to directories containing non-validated methods while having read-only access to validated method directories (see screenshot below). Additional protection is supplied by the checksum system for all records, which protects files from inappropriate modification. The user id and time/date stamp are applied to every electronic record when it is saved.

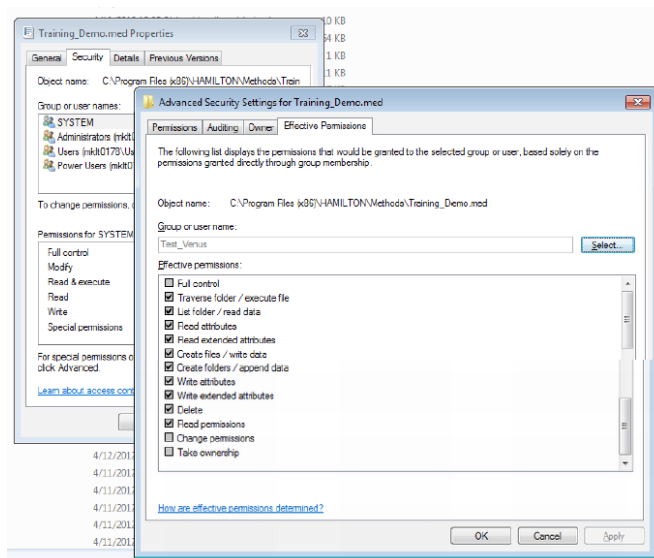

User groups can be given different levels of access to files and directories with Windows 7 or Windows 10 security. For example, the Lab Method Programmer will have full control to modify, execute, read and write method files, while the Lab Operator will have read-only access to method files.

User Group	Allowed Function
Lab Operator	Allowed to run validated methods
Lab Operator 2	Allowed to run validated methods and move labware using the Layout Editor
Lab Method Programmer	Allowed to change methods, labware and sequences
Lab Service	Hamilton Trained Field Service Engineers with full access in order to install and service the system
Lab Remote Service	Allowed to only read data

These are the user groups recognized by Vector/VENUS software for the function protection features. Vector/VENUS software checks the user's user group identity to appropriately restrict their functional access to the software.

Location Checks - 21 CFR Part 11.10 (h)

Use of device (e.g. terminal checks) to determine, as appropriate, the validity of the source of data input or operational instruction.

This requirement is applicable to a source of data (e.g. plate reader) that can receive commands from more than one system, such as on a network. The source of data instrument would have to question the source of the command to ensure that only the authorized workstation is the actual source of the commands. Hamilton workstations have hardwired connections to the computer. For unique instruments, location checks are unnecessary. In the event of identical instruments under control by the same computer, the node identity of the second instrument must be changed from the default setting during installation, creating a unique address for each of the identical instruments. This differentiates the systems to the computer. Correct instrument identification is verified during instrument installation.

Education/Training - 21 CFR Part 11.10 (i)

Determination that persons who develop, maintain, or use electronic record/electronic signature systems have the education, training, and experience to perform their assigned tasks.

Hamilton supplies training and application support as necessary to assist in developing and maintaining application performance. After training with a Hamilton representative, each trainee receives a certificate of training completion. This certificate can be used to document adequate training for use of a Hamilton instrument. Internal training programs and documentation need to be developed and documented by the end user laboratory.



Certificate for user training. Training certificates must be maintained by laboratory SOPs.

Written Policies - 21 CFR Part 11.10 (j)

The establishment of, and adherence to, written policies that hold individuals accountable and responsible for actions, initiated under their electronic signatures, in order to deter record and signature falsification. This is a laboratory procedure, separate from Hamilton instrumentation.

Document Controls/Audit Trails - 21 CFR Part 11.10 (k (1))

Adequate controls over the distribution of, access to, and use of documentation for system operation and maintenance.

This rule applies to the system documentation, which describes how a system operates and is maintained. System documentation includes, but is not limited to, operation manuals, help files, SOPs, access information, operating system manuals and privilege logs. This rule only pertains to documentation that can be changed by individuals within an organization. Hamilton instrumentation documentation such as operation manuals or help files can only be changed by Hamilton. Laboratories do not need to control these documents. Even though laboratories do not need a change control procedure for these documents, they are responsible for archiving and making them accessible to the appropriate users. Laboratories are also responsible for protecting their own documents

regarding Hamilton instrumentation. Hamilton regulates the distribution of, access to and use of system documentation by ISO-9001 compliant procedures.

Hamilton Company Controlled Documents
Software Manuals
Hardware Manuals
Technical Bulletins
Service Bulletins
Help Files

These documents are controlled by Hamilton's change-control process. Laboratories do not need to maintain change documentation on these documents. However, the laboratory is responsible for archiving and making these documents available to the appropriate users.

Document Controls/Audit Trails - 21 CFR Part 11.10 (k (2))

Revision and change control procedures to maintain an audit trail that documents time-sequenced development and modification of systems documentation.

This rule is similar to the above in that it refers to the same documents mentioned above. Hamilton maintains an internal change control process for documentation by procedures that are consistent with the 21 CFR Part 11 guidelines. Laboratories are responsible for the change control process of their internal documents.

8.5 Appendix E: Glossary

Term	Definition
<i>ADC</i>	Anti-Droplet Control to prevent drops while pipetting highly volatile solvents.
<i>Adjustment</i>	Detailed positional setting for the hardware.
<i>Agency</i>	Food and Drug Administration
<i>Air Displacement Tip</i>	Hamilton CO-RE disposable tip or commercial pipetting tip.
<i>Aliquot</i>	Aliquots are identical small volumes of liquid.
<i>APE</i>	Application Engineering.
<i>Aspirate</i>	To draw up liquid into a pipetting device.
<i>Autoload</i>	Hardware assembly that enables automatic loading of the ML STAR. It consists of a loading head movable in Y direction, which draws the carriers into the ML STAR and reads the barcodes on them.
<i>Autoload Tray</i>	Hardware unit. The carriers can be placed on it and held outside the ML STAR. The loading tray is attached to the ML STAR, to support the automatic loading and unloading process.
<i>Barcode Mask</i>	The barcode mask defines the basic structure of a barcode. It is a pattern to which a barcode must conform. The assignment of a specific labware item can be done in this manner. The barcode mask can require a barcode to contain specific strings at fixed positions. It can also contain wildcards.
<i>Barcode Reader</i>	Device for reading sample/plate Barcodes. Part of the Autoload.
<i>Basic Microlab STAR</i>	Basic parts of the ML STAR with pipetting arm and deck, to which the loading unit and the options can be added on.
<i>Bilateral Identification</i>	A method of verifying an individual's identity based on a user id and password system.
<i>Biometric Identification</i>	A method of verifying an individual's identity based on measurement of the individual's physical feature(s) or repeatable actions where those features and/or actions are both unique to that individual and measurable.
<i>BVS</i>	Basic Vacuum System for automation of vacuum based filtration kits. Predecessor of the CVS.
<i>Carrier</i>	Unit for loading plates, tubes and tips on the ML STAR deck. Can be used manually or, if possible, by the Autoload option.

Term	Definition
Checksum	A system by which the authenticity of a file can be checked, based on the binary code. This protects files from being improperly modified. The checksum value is updated every time a file is legitimately saved. If the checksum doesn't match when the file is reopened, the file has been improperly modified and the file is blocked from use.
<i>cLLD</i>	Capacitive Liquid Level Detection.
Closed System	An environment in which system access is controlled by persons who are responsible for the content of electronic records that are on the system.
<i>CLT</i>	MULTIFLEX CORE-LID TOOL; Suction cup that can be picked up by a CO-RE pipetting channel to move around lids.
<i>Container</i>	A container defines a tube, vessel or a single well of a plate.
<i>Container Identification</i>	Barcode for the identification of a container. Serves for a unique identification of a vessel (e.g. a sample test tube).
<i>Continuous Loading</i>	Refers to the loading of elements that can be manipulated onto the ML STAR after processing has been started.
CVS	Crystal Vacuum System for automation of vacuum based filtration kits.
<i>Decapper Module</i>	Hardware assembly that enables opening and closing of tubes with screw-top caps. To be used in combination with the Tube Twister Channel.
<i>Deck</i>	The work surface (work area) of the ML STAR. The area where the pipetting channels perform liquid handling or transport steps. The deck is divided into equal tracks, which are occupied by labware.
<i>Deck Layout</i>	A collection of labware placed upon a deck.
<i>Dispense</i>	To distribute quantities of liquid from a pipetting device.
<i>Docking Station</i>	The long bar at the back of the ML STAR instrument for guiding the cables and the tubing for accessories, such as Wash Stations, TCC, etc..
<i>DWP (Deep Well Plate)</i>	Microplate with large well volume, used when higher volumes of sample need to be stored or collected (e.g. chemistry libraries, for cell culture or filtration applications). In general we assume a plate with 96 wells (8 x 12) 9mm wide, standard SBS format. There are also DWPs with higher or lower well number.
Electronic Records	Any combination of text, graphics, data, audio, pictorial, or other information represented in digital form that is created, modified, maintained, archived, retrieved, or distributed by a computer system.

Term	Definition
Electronic Signature	A computer data compilation of any symbol or series of symbols executed, adopted, or authorized by an individual to be the legally binding equivalent of the individual's handwritten signature.
<i>Firmware</i>	Lower Level program code that is carried out on the processors of the ML STAR Instrument.
<i>Front Cover</i>	Protective covering for the ML STAR Instrument, featuring a hinged front window made of transparent Plexiglas. With this option and assembly, the work surface of the ML STAR is covered in such a way that it is shielded from user intervention and other outside influences (such as dust). At the same time, it protects the user from the movements of the ML STAR.
<i>Good Laboratory Practices</i>	Also written as GLP, are set of appropriate laboratory behaviors which should be observed.
<i>Hardware Error</i>	Type of error that is caused by a technical problem with the hardware.
<i>HHS</i>	Hamilton Heater Shaker. Unit to heat and / or shake microplates in SBS format.
<i>HSB</i>	Heater Shaker Box. Interface unit which is needed if more than two HHS are being used.
<i>HSL</i>	Hamilton Standard Language
<i>Instrument</i>	Hardware of the ML STAR (mechanics, electronics, and firmware)
<i>Instrument Commands</i>	The commands made available by the firmware for controlling the ML STAR.
<i>Instrument Steps</i>	The commands made available by the firmware for controlling the ML STAR.
<i>Labware</i>	Refers to movable items to be placed on the ML STAR deck, such as carriers, containers, or racks.
<i>LIMS</i>	Higher level data processing system, generally known as Laboratory Information Management System, also LMS.
<i>Liquid</i>	Includes all kinds of liquids, among which are included reagents, controls, standards, wash fluids.
<i>LLD</i>	<i>Liquid Level Detection</i> – Detection of liquid surface which may be achieved either by pressure or capacitive signal detection.

Term	Definition
<i>Loading, Unloading</i>	The process by which a plate, tube or tip carriers are brought on and off the ML STAR deck. This can happen automatically by means of the Autoload Option, or manually.
<i>MAD</i>	Monitored Air Displacement: aspiration monitoring feature. During the aspiration process, the pressure within the pipetting channel is measured in real time.
<i>Method</i>	The method contains all instruction that must be executed during a run.
Method Files	A method in Vector/VENUS software is defined by the .med, .stp, .lay, .sub, .res and .hsl files. These six files are necessary for running a method in Vector/VENUS software.
<i>MFX</i>	Multiflex: A multiple-use carrier base concept.
<i>Microplate</i>	See MTP.
<i>MPH</i>	Multi-Probe Head, a pipetting device consisting of an array of pipetting channels (96 or 384).
<i>MTP (Microtiter plate or microplate)</i>	In general, a microtiter plate (or microplate) is assumed to have 96 wells (8 x 12) 9mm wide. There are also plates with 384 wells (16 x 24 / 4.5mm), or others with a different size
<i>NTR</i>	Nested Tip Rack
<i>Orbit / Amplitude (of the Hamilton Heater Shaker)</i>	<p>The orbit (rotation distance) is defined as peak to peak distance in one direction (e.g. distance between extreme positions in the Y-Direction of the plate measured in millimeters [mm]).</p> <p>The amplitude is defined as the distance from the center of the shaking movement and it is 50% of the peak to peak distance.</p>
<i>P/N</i>	Part Number
<i>Pause</i>	Interruption of processing. The current processing steps are completed.
<i>Pipetting</i>	Transfer of liquids from one container to another.
<i>Pipetting Arm</i>	Assembly equipped with the pipetting device and/or plate handler, as well as the common X-drive.
<i>Pipetting Channel</i>	Hardware assembly including the function of picking up a tip aspirating, dispensing, tip eject, liquid level detection and the Y/Z-movements
<i>Pipetting Module</i>	Firmware (-processor-program) which controls a pipetting channel, in which category are included the Y and Z pipetting movements, and the LLD.

Term	Definition
<i>pLLD</i>	Pressure-based Liquid Level Detection.
<i>Pooling</i>	Pipetting of different liquids in one well; 1, 2, 3...to n and n to 1, 2, 3...
<i>Processing Step</i>	Defines what must be carried out on the ML STAR instrument, as well as the location it must be carried out and possible interaction with other system components or labware. The action is defined in accordance with the methods, the loading and the tasks.
<i>Pump Station</i>	Part of the needle/tip wash station. Its function is to pump wash liquid to and from the wash station.
<i>Rack</i>	Group of containers, as DWP, MTP, etc.
<i>Rack Identification</i>	Barcode for rack identification
<i>Random Access</i>	Means that every pipetting channel can access any position anywhere on the work area.
<i>Run</i>	Execution of the processing steps defined in the method with the aim of processing one or more liquids and containers (e.g. MTP). The run is a series of timed commands, in order to carry out processing on the ML STAR according to the processing plan. The run can include a reloading of elements.
<i>Run Abort</i>	Cancelled run by the user or by the ML STAR.
<i>Run Visualization</i>	Visualization of the current run, reporting the status of the ML STAR.
<i>Sample</i>	Refers to a liquid in a unique identified container which is to be processed.
<i>SBS Format</i>	Standard format for microplates, defined by the Society for Biomolecular Screening.
<i>SOP</i>	Standard Operating Procedure.
<i>Stacker</i>	Storage unit for racks.
<i>T</i>	Abbreviation used for "track". The ML STAR instruments have equal partitions of 22.5mm, equivalent to 1-T. Labware carriers are adapted to those partitions.
<i>TADM</i>	Total Aspiration and Dispense Monitoring. The pressure inside each individual pipetting channel is monitored, during aspirate and dispense.
<i>TCC</i>	Temperature controlled carrier.
<i>Tip</i>	Disposable tip for pipetting.

Term	Definition
<i>Tip Rack</i>	Frame that holds the tips.
<i>Tip Waste</i>	Container for ejected tips.
<i>Touch-Off</i>	Type of dispensing where the tip approaches the bottom of the empty container so close as to allow the dispensed droplet to have simultaneous contact with the tip and the container bottom.
<i>Trace</i>	Record of the status during processing.
Trace Files	The file generated by Vector/VENUS software for every runtime event. The trace file contains all the events of the run, date, time and user id information.
<i>Tube</i>	A container for liquid, usually having a circular cross-section, and a cylindrical length section.
<i>Tube Twister Channel</i>	Hardware assembly including the function of picking up and transporting of a tube, spin the tube (mix the liquid within the tube) as well as identify the barcode of the tube.
<i>User</i>	User of the software. Access rights for different types of users can be defined, such as operators, laboratory managers, etc.
Validation	Confirmation by examination and provision of objective evidence that the system specifications conform to user needs and intended uses, and that all requirements can be consistently fulfilled.
Vector/VENUS Software	Vector/VENUS software is the software designed for Hamilton robotic instrumentation control. The software provisions for 21 CFR Part 11 applies to all instruments controlled by the software including the ML STAR instruments.
<i>Verification Kit</i>	Balance, liquid, disposable tips to verify the function (volume check) of the ML STAR pipetting heads.
<i>Waste Container</i>	A device on the ML STAR deck to collect used disposable tips.
<i>Well</i>	The individual container of a MTP or DWP.
<i>Well Type</i>	Geometrical shape of the well, such as U, V or flat.
<i>Side Touch</i>	Type of dispensing whereby the tip or the needle touches the side of a container and thus releases the droplet.
<i>Work Area</i>	The area of the ML STAR to which access is provided during the processing. Elements to be pipetted or handled can be placed in this area.

Term	Definition
<i>Worklist</i>	Information according to which a method is to be executed on the ML STAR. A worklist may contain different parameters (e.g. Pipetting volume, heating temperature, shaking speed, etc.).
